

# Accessories

## DCF803-0016, FEX-425-Int and DCF803-0035

The field exciters DCF803-0016, FEX-425-Int and DCF803-0035 are half controlled 3-phase converters. All field exciters are based on the same control board SDCS-FEX-4. The board is equipped with its own synchronization and current control. The current measurement circuit is automatically scaled depending on the rated field current of the motor. The field exciter is fully controlled and monitored by the armature converter via drive-to-drive communication.

The field exciter is prepared to operate as 3-phase as well as single-phase converter. For single-phase operation connect terminals U and W.

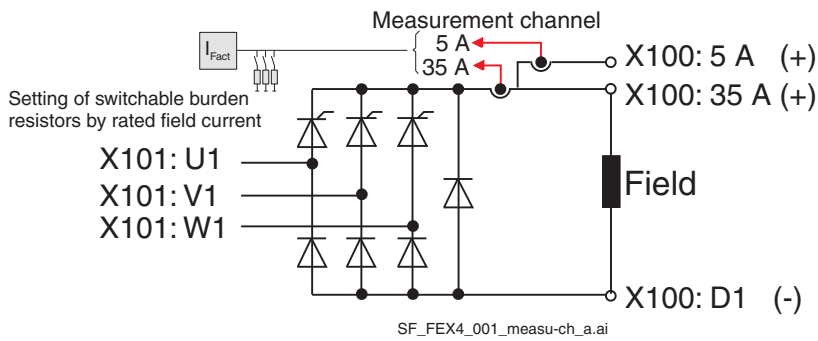

Layout of the SDCS-FEX-4

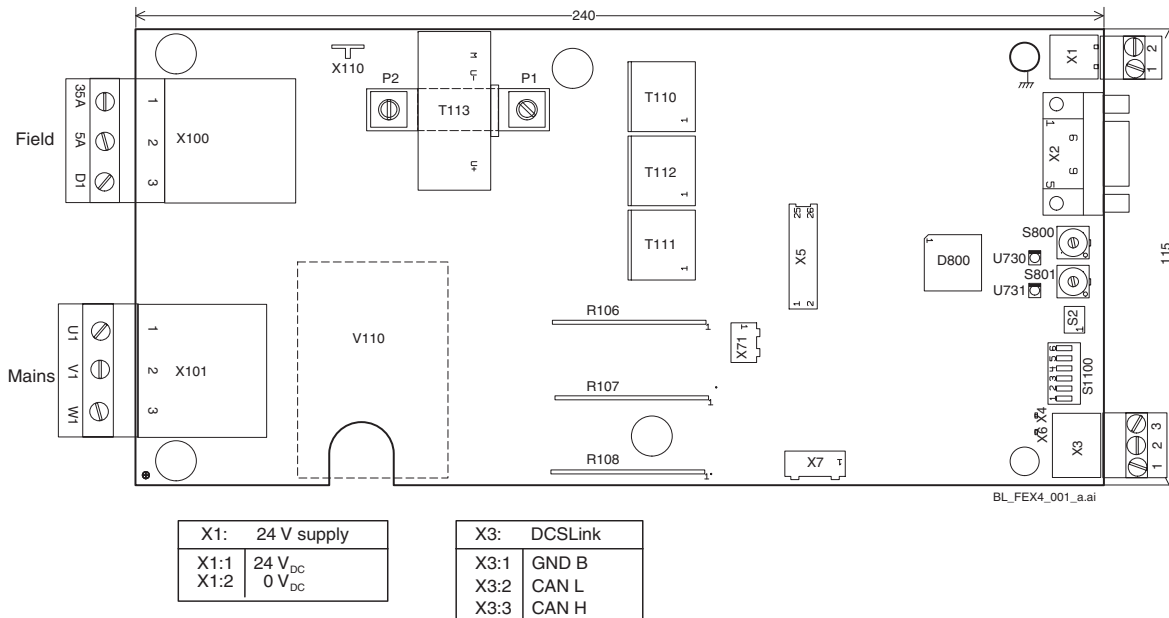

## Electrical data

<b>Power part</b>	
AC input voltage	110 V -15% - 500 V +10%; single or 3-phase
AC input current	< DC output current
Frequency	Same as DCS converter
AC isolation voltage	600 V
Line reactor	External
Line fuses	KTK25 for FEX-425-Int; external for DCF803-0016 and DCF803-0035
DC output current *	0.3 A - 16 A = DCF803-0016 0.3 A - 25 A = FEX-425-Int 0.3 A - 35 A = DCF803-0035
Powerloss	< 130 W (at rated current)
<b>Auxiliary supply</b>	
DC input voltage	24 V <sub>DC</sub>
DC input current	< 200 mA supplied via X51 of SDCS-DSL-4
Buffering	10 ms

\* 3-phase or single-phase operation

## Control unit

The control includes the following main blocks:

- Micro controller H8 for current control, synchronization and fault handling.
- 2 channel measurement of actual field current in the DC circuit.
- High ohmic measurement of AC voltage. Residual resistance to ground  $\approx 1.6 \text{ M}\Omega$
- H8 controller for drive-to-drive communication based on CAN standard.
- Driver circuit to fire the half control bridge.
- The firmware is stored in a flash memory and contains:
  - The PI current controller for the field circuit.
  - The fault and reset logic.
  - The synchronization and PLL function.
  - The setting of the current measurement channel.

All parameters are set from the armature converter via drive-to-drive communication. The field current reference, actual field current, current control and status bits are cyclic sent via drive-to-drive communication.

The field exciter is equipped with an autoscaling function of the burden resistors based on the nominal field current of the motor.

## Power part

The power part is a 3-phase half controlled bridge with free-wheeling diode.

The external field exciter DCF803-0016 and DCF803-0035 are 3-phase half controlled bridges including snubbers based on the SDCS-FEX-4. Line fuses, line reactors and transformers are installed outside the housing.

The FEX-425-Int (internal field exciter) can be installed in D4+ and D5 converters. The unit is based on a SDCS-FEX-4. For a D4+ the supply must be connected via line reactors and fuses located outside of the module.

For a D5 the supply must be connected via line reactors outside of the module. The fuses are installed in the module.

For single-phase operation connect terminals U and W. For single-phase operation an autotransformer for voltage adaptation is recommended.

Please see comparison of output voltage ripple between single-phase and 3-phase operation.

Voltage ripple of  $U_{DC}$  voltage depending on operation modes

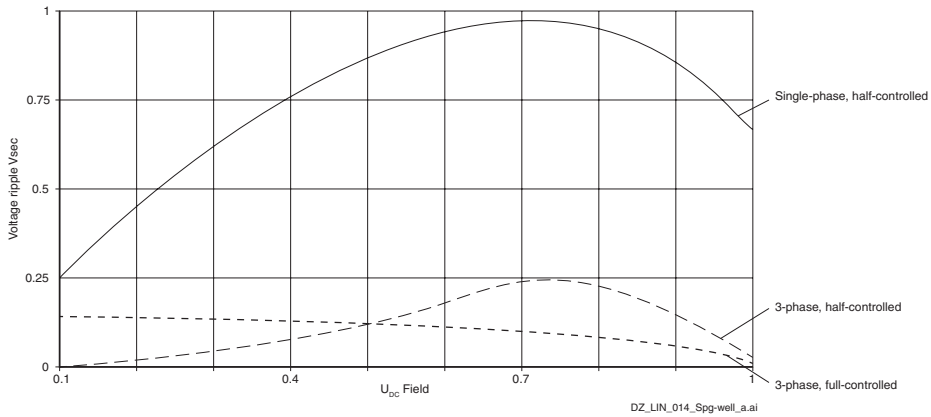

**DCSLink communication**

The field converter is controlled from armature converter via DCSLink based on CAN hardware.

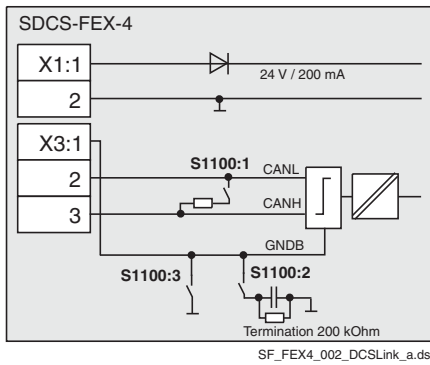

Incoming power		Remarks
24 V	≤ 200 mA	24 V grounded via X51 of SDCS-DSL-4

DSL communication		Remarks
Bus termination		
S1100:	1 = ON	120 Ohm
	1 = OFF	No termination
Ground termination		
S1100:	2 = ON	200 kOhm R-C ground termination
	3 = ON	0 Ohm ground termination
	2, 3 = OFF	No termination

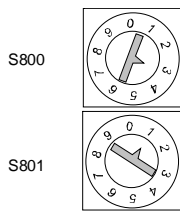

Node address is set by: S800 digit 0 (node address 00 is not possible!)

S801 digit 10

Same node address must be selected in the corresponding armature converter.

Example: Node address = 13 ==> S800 = 3 and S801 = 1

The communication speed is set by S1100

S1100:6	S1100:5	S1100:4	Baudrate [kBaud]	Selection in armature converter, parameter (94.02)
OFF	OFF	OFF	20	0
OFF	OFF	ON	50	1
OFF	ON	OFF	125	2
OFF	ON	ON	250	3
ON	OFF	OFF	500	4
ON	OFF	ON	800	5
ON	ON	OFF	888	6
ON	ON	ON	1000	7

**RS232-Port**

The RS232 interface is used for download the 'Field exciter firmware package'.

More information see [RS232 interface](#).

The firmware download is activated by setting S2:1-2 before the auxiliary voltage is switched ON. Field exciter mode is S2:3-4 (default).

## Diagnostics

All messages are sent to the armature converter and displayed in Signals (9.17) to (9.20). If communication is broken or node numbers are mixed up the simple fault display on the SDCS-FEX-4 can be used. Therefore the unit is equipped with two small LEDs.

V730 = Green

V731 = Yellow

Following messages are displayed:

Both OFF	No 24 V supply
Green and yellow continuous	No firmware
Green blinking	16 A / 25 A / 35 A output active, waiting for DCSLink communication
Green continuous	16 A / 25 A / 35 A output active, DCSLink communication OK
Yellow blinking	5 A output active (X100:2), waiting for DCSLink communication
Yellow continuous	5 A output active (X100:2), DCSLink communication OK

Green and yellow toggling:

X times yellow	Y times green	Warning or Fault	
X = 1	Y = 1	Warning	Phase missing, see parameter (45.22) / (45.23)
	Y = 2	Warning	Temperature heatsink
	Y = 6	Warning	Parameters added
	Y = 7	Warning	Parameter up- or download failed
	Y = 8	Warning	Compatibility
	Y = 9	Warning	Parameters restored
X = 2	Y = 1	Fault	DCSLink communication
	Y = 2	Fault	Supply voltage synchronization
	Y = 3	Fault	Overcurrent
	Y = 4	Fault	Fast voltage rise, see parameter (45.01) / (45.15)
	Y = 5	Fault	AC supply voltage < 30 V <sub>AC</sub>
	Y = 6	Fault	AC supply voltage > 650 V <sub>AC</sub>
	Y = 9	Fault	Temperature heatsink
	Y = 10	Fault	Parameter flash read
	Y = 11	Fault	Compatibility
	Y = 12	Fault	Auxiliary voltage
	Y = 14	Fault	General hardware (no reset possible)
	Y = 15	Fault	General firmware (no reset possible)

[Line reactors \(L3\).](#)

[Autotransformer \(T3\).](#)

[Fuses \(F3.x\).](#)

### DCF803-0016 and DCF803-0035 configuration

3-phase connection, see also parameters (45.22) and (45.23).

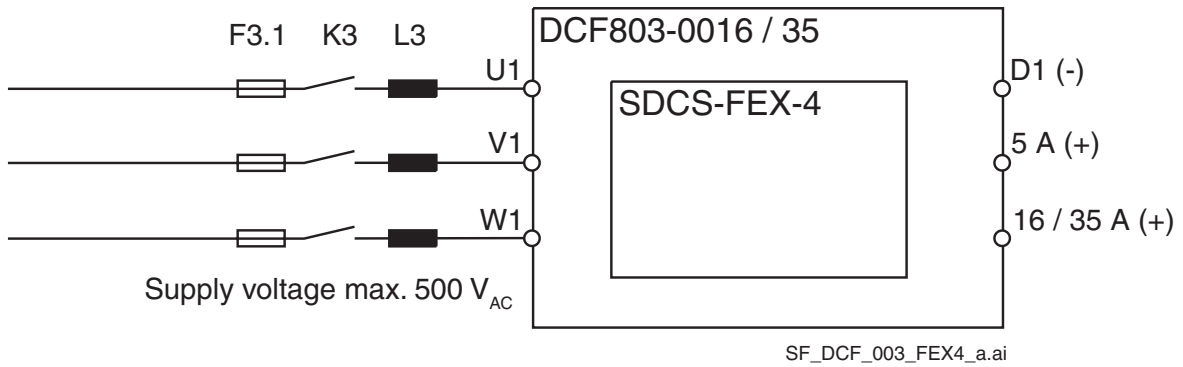

Single-phase connection, see also parameters (45.22) and (45.23).

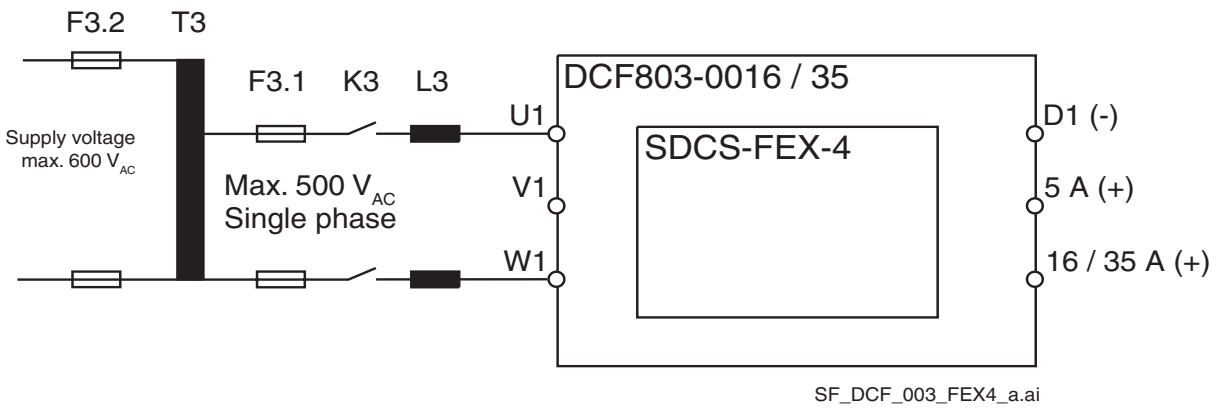

**Dimensions**

**DCF803-0016**

Dimensions in mm  
Weight appr. 6 kg

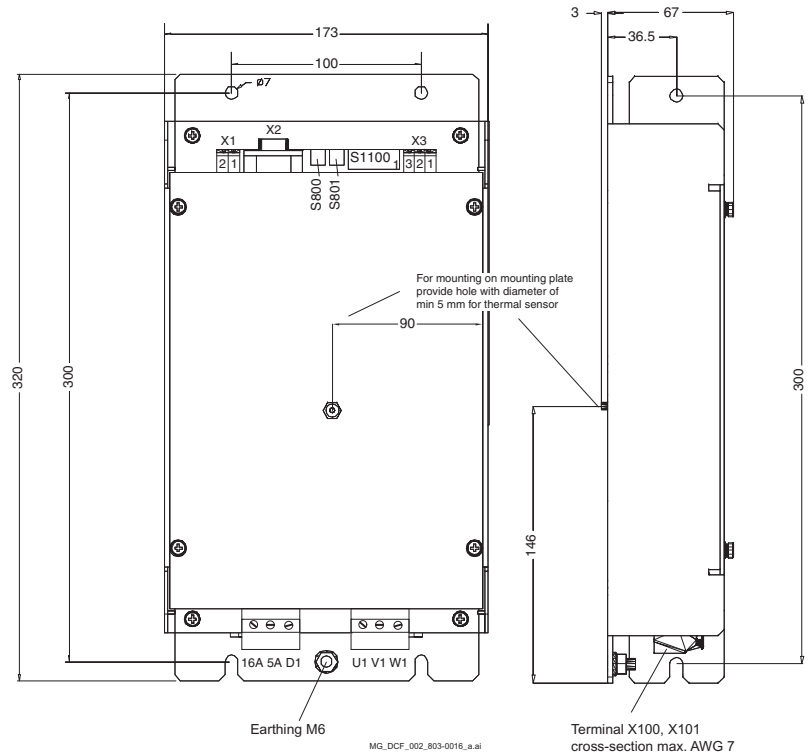

**DCF803-0035**

Dimensions in mm  
Weight appr. 6 kg

