

CE 680 M511

Piezoelectric Accelerometer with Integrated Electronics Type CE 680 M511

FEATURES

- Designed for medium temperature industrial applications (-50°C to +120°C)
- Frequency response
1 Hz to 9 kHz: $\pm 10\%$
0.5 Hz to 14 kHz: -3 dB
- Shear mode operation, therefore no output due to thermal transients
- Hermetically sealed for harsh environments
- Case insulated, internally shielded
- ESD protection



DESCRIPTION

The CE 680 M511 is an all-purpose vibration sensor designed for use in harsh industrial machinery environments. It uses the industry standard 2-wire voltage transmission technique with a constant current supply. The output signal has a sensitivity of 100 mV/g.

Thanks to the accelerometer's isolated ground and internal shield, no ground loops or frame voltage are present to disturb the measurement.

The CE 680 M511 shows extremely low noise levels and exceptional bias voltage stability at elevated temperatures.

SPECIFICATIONS

Note: Unless otherwise stated, all values listed are typical values, referenced at +23°C, 24 VDC supply, 6 mA constant current and 120 Hz

OPERATING

Sensitivity (at +25°C)	: 100 mV/g ±5%
Dynamic range	: 80 g
Transverse sensitivity (maximum)	: 5% of axial
Linearity	: 1% up to full scale
Frequency response (nominal)	
• 3 Hz - 5 kHz	: ±5%
• 1 Hz - 9 kHz	: ±10%
• 0.5 Hz - 14 kHz	: -3 dB
Resonant frequency	: 30 kHz
Temperature response	
• <i>Typical deviations</i>	
-55°C to +120°C	: ±5%
-55°C	: -5%
120°C	: +3%

ELECTRICAL

Input supply current	: 2 to 10 mA
Supply voltage for current source	: 18 to 30 V _{DC}
Bias output voltage	: 12 V _{DC}
Electrical noise (equivalent g)	
• <i>Broadband:</i> - 2.5 Hz to 25 kHz	: 700 µg
• <i>Spectral:</i> - 10 Hz	: 10 µg/√Hz
- 100 Hz	: 5 µg/√Hz
- 1 000 Hz	: 5 µg/√Hz
Output impedance (maximum)	: 100 Ω
Grounding	: Case isolated, internally shielded
Reversed polarity	: Protected

ENVIRONMENTAL

Temperature range	: -55°C to +120°C
Vibration limit	: 500 g (peak)
Shock limit	: 5 000 g (peak)
Base strain sensitivity	: Maximum, 0.0002 g peak/µε
ESD Protection	: Yes
Electromagnetic sensitivity (equivalent)	: 70 µg/gauss
Sealing	: Hermetically sealed

PHYSICAL

Sensing element design	: PZT ceramic / shear
Weight	: 90 gr
Case material	: 316 L stainless steel

SPECIFICATIONS (Continued)

Mounting	: 1/4 - 28 UNF tapped hole
Mounting torque	: 3 Nm
Output connector	: 2 pin, MIL-C-5015 style
Mating connector	: MS3106F-10SL-4S or equivalent

CALIBRATION

Dynamic calibration at factory. No subsequent calibration necessary.

MECHANICAL DRAWING

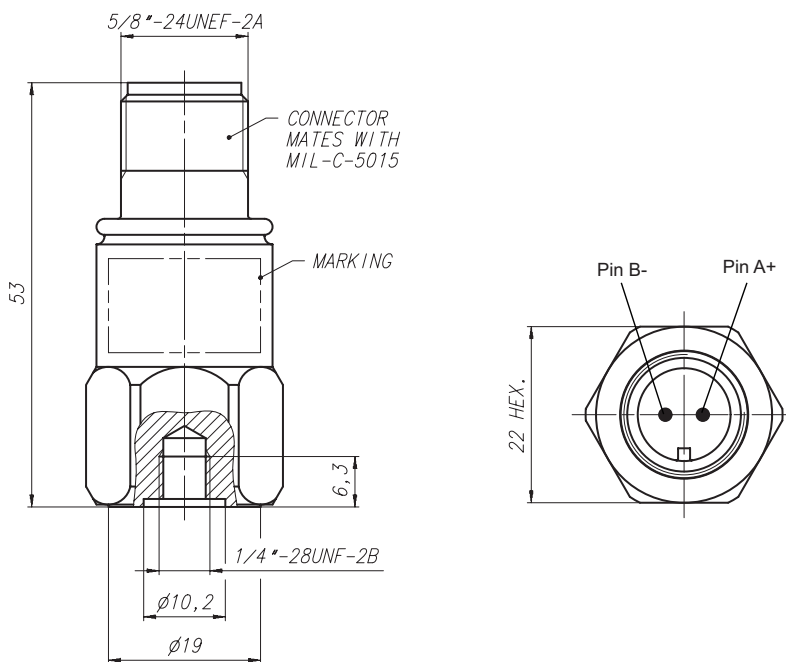

ACCESSORIES

Supplied

Item	Type
• Adaptor stud	1/4 - 28 UNF

Optional

Item	Type	Part number
• Cable	EC 318	922-318-000-xxx
	EC 319	922-319-000-xxx
• Mounting adaptor	MA 122_012 1/4 - 28 UNF to M6 (with conic base)	809-122-000-012
• Insulating stud	MA 122_021 1/4 - 28 UNF to M6 (with conic base)	809-122-000-021