

24 VDC Positive/Negative Logic, 32 Point Input IC693MDL655

The *24 volt DC Positive/Negative Logic Input* module for the Series 90-30 Programmable Logic Controller provides 32 discrete input points. The inputs are arranged in four isolated groups of eight (A1 - A8, B1 - B8, C1 - C8, and D1 - D8); each group has its own common. The inputs are positive or negative logic inputs and will operate at levels up to 30V.

Backplane isolation between the field side and logic side is provided by opto-couplers on the module. Isolation is also provided between the four groups of inputs on the module, however each group of eight inputs is referenced to the same user common connection. There are no special fault or alarm diagnostics reported. LED indicators (labeled A1 - A8, B1 - B8, C1 - C8, D1 - D8) at the top of the module provide the ON/OFF status of each input point.

This module is configured as a 32-point input type and uses 32 bits of discrete %I input data. Current into an input point results in a logic 1 in the input status table. Power to operate field devices can be supplied by the user, or from the isolated +24 VDC supply available at the module's I/O connectors. This module can be installed in any I/O slot of a 5 or 10-slot baseplate in a Series 90-30 PLC system.

Connections to the input circuits are made from the user's input devices to two male (pin-type) 24-pin connectors (Fujitsu FCN-365P024-AU) mounted on the front of the module. The connector mounted on the right of the module (front view) interfaces with groups A and B. The connector on the left side of the module interfaces with groups C and D.

Wiring from the module's connectors to field devices is made through a cable having a mating female connector on one end and stripped and tinned wires on the other end. You can purchase a pair of pre-wired cables, catalog numbers IC693CBL327 and IC693CBL328 or, if required for your application, build your own cable. Refer to "Building Cables for 24-Pin Connectors" in the IC693CBL327/328 data sheet in Appendix C of this manual for more information.

Table 6-12. Specifications for IC693MDL655

Rated Voltage	24 volts DC, Positive or Negative Logic
Input Voltage Range	0 to 30 volts DC
Inputs per Module †	32 (four groups of eight inputs each)
Isolation	1500 volts between field side and logic side 250 volts between groups
Input Current	7.0 mA (typical ON current @ 24 VDC)
Input Characteristics	
On-state Voltage	11.5 to 30 volts DC
Off-state Voltage	0 to 5 volts DC
On-state Current	3.2 mA (minimum)
Off-state Current	1.1 mA (maximum)
On response Time	2 ms maximum
Off response Time	2 ms maximum
Internal Power Consumption	195 mA (maximum) from +5V bus on backplane; (29 mA +0.5 mA/point ON +4.7 mA/LED ON) 224 mA (typical) from isolated +24V bus on backplane or from user input supply @ 24 VDC and all 32 inputs ON)

† Maximum number of inputs ON is dependent on ambient temperature as shown in the figure below.
Refer to data sheet GFK-0867F (or later revision) for product standards and general specifications.

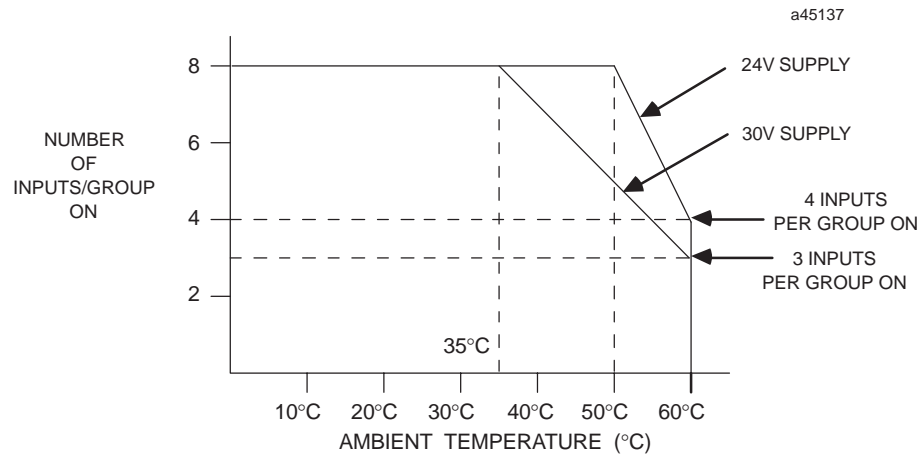
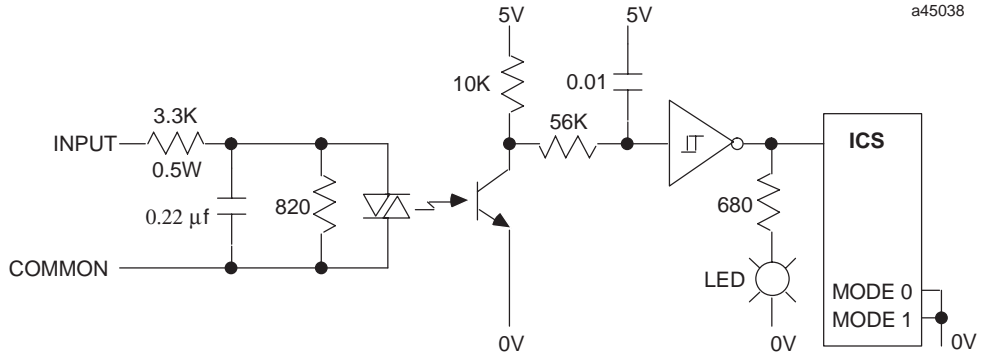

Figure 6-19. Input Points vs. Temperature for IC693MDL655

IC693MDL655 Input Module Field Wiring Information

The following two figures provide wiring information for connecting user supplied input devices and power source to the 24 volt DC (TTL) positive/negative logic input module. The first figure shows a typical input circuit. The second figure shows how field devices are connected to the module.



Module point numbers in the following figure are shown in **bold text**.

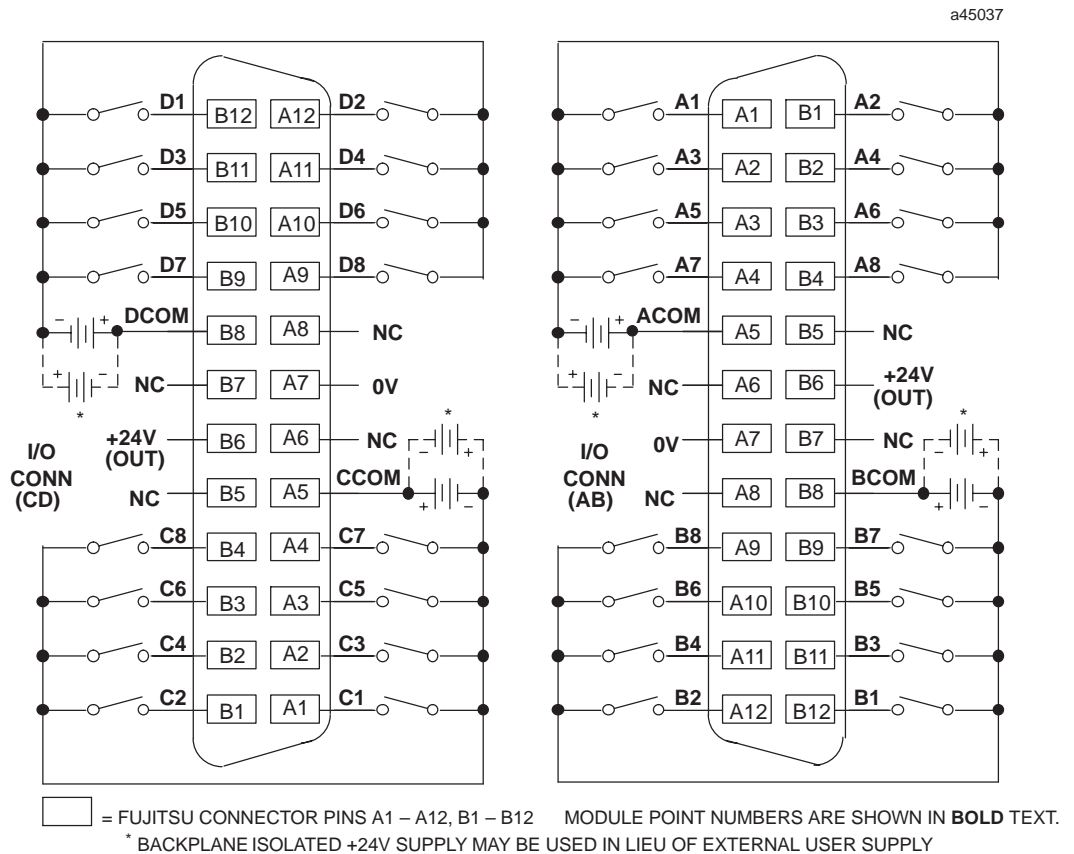

Figure 6-20. Field Wiring 24 Volt DC Positive/Negative Logic 32-Point Input Module - IC693MDL655

Field Wiring Work Sheet for IC693MDL655

The following table is provided for the convenience of our customers as an aid to wiring the 24-pin connectors using cable IC693CBL315. It includes all of the required wiring information in one table. This table has the following information:

- *module point number:* A1 - A8, B1 - B8, C1 - C8, D1 - D8, voltage and common points
- *connector pin number:* A1 through A12, and B1 through B12
- *cable pair number:* pair 1 through pair 12
- *wire color code:* base color or base color with tracer color

Columns are also provided for circuit references and customer wire numbers. Please copy and use the work sheets on this and the following page as needed when wiring the 24 VDC Positive/Negative Logic, 32 Point Input module.

Wiring for Module Groups A and B (connector on right front of module)

Reference	Module Point Number	Connector Pin Number	Cable Pair Number	Wire Color Code	Wire Number
	A1	A1	1	Brown	
	A2	B1	7	Violet	
	A3	A2	1	Brown/Black	
	A4	B2	7	Violet/Black	
	A5	A3	2	Red	
	A6	B3	8	White	
	A7	A4	2	Red/Black	
	A8	B4	8	White/Black	
	A Common	A5	3	Orange	
	N/C	B5	9	Gray	
	N/C	A6	3	Orange/Black	
	+24V OUT	B6	9	Gray/Black	
	0 VOLTS	A7	4	Yellow	
	N/C	B7	10	Pink	
	N/C	A8	4	Yellow/Black	
	B Common	B8	10	Pink/Black	
	B8	A9	5	Dark Green	
	B7	B9	11	Light Blue	
	B6	A10	5	Dark Green/Black	
	B5	B10	11	Light Blue/Black	
	B4	A11	6	Dark Blue	
	B3	B11	12	Light Green	
	B2	A12	6	Dark Blue/Black	
	B1	B12	12	Light Green/Black	