

Inductive Gauging Sensors

EX-200 Series

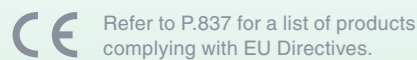

Features

- Linearity of $\pm 1\%$ of F.S.
- High response speed of up to 18 kHz
- Resolution of 0.04% of F.S.
- Sensor head housing IP67 rated

Expert Engineering Sites

www.measurecentral.com



Application Finder helps you find a solution based on your requirements.

Accurate analogue output of minute displacement

The EX-200 Series measures target displacement with a resolution of 0.04% F.S. (0.4 μm with the EX-305 sensor head). The dual analogue outputs (voltage/current) enable connection to external equipment.

Linearity of $\pm 1\%$ of F.S.

Using the built-in lineariser circuit, the EX-200 Series accurately outputs absolute displacement values.

High response speed

The EX-200 Series offers a response frequency of up to 18 kHz (with the EX-305), allowing measurement of rapidly vibrating targets.

Lineup

| Type | Model | | Appearance | Measuring range | Resolution | Mounting size |
|----------------------|-------------|------------|------------|-----------------|-------------------|---------------|
| | Sensor head | Controller | | | | |
| Cylindrical | EX-305 | EX-201 | | 0 to 1 mm | 0.4 μm | $\phi 5.4$ mm |
| Threaded | EX-110 | EX-202 | | 0 to 2 mm | 0.8 μm | M10 |
| Cylindrical/Threaded | EX-416 | EX-205 | | 0 to 5 mm | 2 μm | M16 |
| | EX-422 | EX-210 | | 0 to 10 mm | 4 μm | M12 |

Specifications

| Type | Model | Cylindrical | Threaded | Cylindrical/Threaded | |
|---|--------------------------|--|----------------|----------------------|----------------|
| | | $\phi 5.4$ | M10 | $\phi 14.5/M16$ | $\phi 22/M12$ |
| Sensor head | | EX-305 | EX-110 | EX-416 | EX-422 |
| Controller | | EX-201 | EX-202 | EX-205 | EX-210 |
| Measuring range | | 0 to 1 mm | 0 to 2 mm | 0 to 5 mm | 0 to 10 mm |
| Analogue output | Output voltage | 0 to 5 V (Output impedance 100 Ω) | | | |
| | Output current | 4 to 20 mA (Applicable load: 0 to 350 Ω) | | | |
| | Resolution | 0.04% of F.S. (Response frequency: LOW) | | | |
| | Linearity | $\pm 1\%$ of F.S. | | | |
| | Response frequency | HIGH | 18 kHz (-3 dB) | 15 kHz (-3 dB) | 13 kHz (-3 dB) |
| | LOW | 1.3 kHz (-3 dB) | | | |
| Disconnection alarm output ² | | NPN: 100 mA (40 V) max., Residual voltage: 1 V max. (N.C.) | | | |
| Functions | | Auto-zero function/Response frequency selecting function | | | |
| Temperature fluctuation | Sensor head ¹ | 0.03% of F.S./ $^{\circ}\text{C}$ | | | |
| | Controller ¹ | 0.04% of F.S./ $^{\circ}\text{C}$ | | | |
| Power supply voltage | | 12 to 24 VDC $\pm 10\%$ | | | |
| Current consumption | | 240 mA max. | | | |
| Ambient temperature | Sensor head | -10 to +60 $^{\circ}\text{C}$, No freezing | | | |
| | Controller | 0 to +50 $^{\circ}\text{C}$ | | | |
| Relative humidity | | 35 to 85%, No condensation | | | |
| Enclosure rating | | Sensor head: IP67 | | | |
| Weight | Sensor head | Approx. 45 g | Approx. 55 g | Approx. 75 g | Approx. 200 g |
| | Controller | Approx. 285 g | | | |

The above data was obtained using a steel target (S45C, SS41, t=1 mm).
When measuring aluminium, copper, or stainless steel targets, refer to the linear characteristics for these materials.
1. When the distance between the sensor head and the target is within 50% of the measuring range.
2. NPN output can easily be converted to PNP output by connecting the optional OP-5148 PNP output converter.

Connections

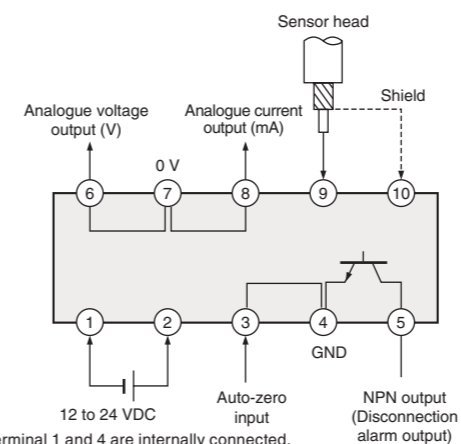

Part Names and Functions

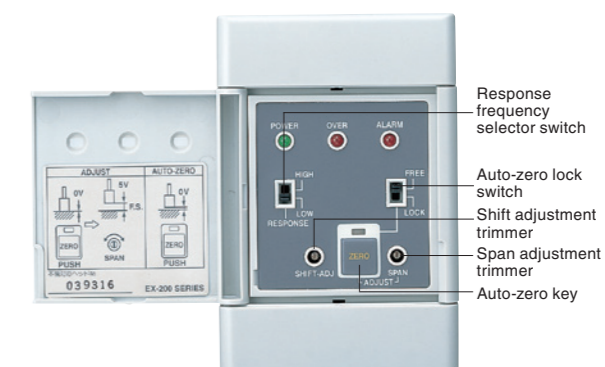

Characteristics

Output characteristics for disc target diameter measurement (Typical)

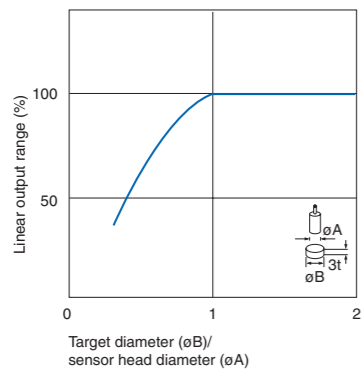

Output characteristics for cylindrical target diameter measurement (Typical)

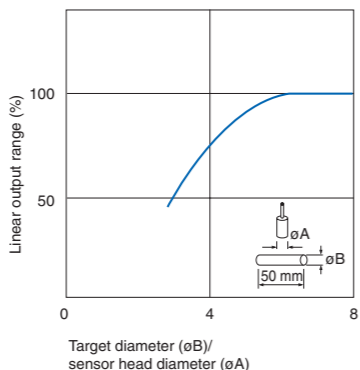

Response frequency vs. output characteristics (Typical)
Response frequency: HIGH

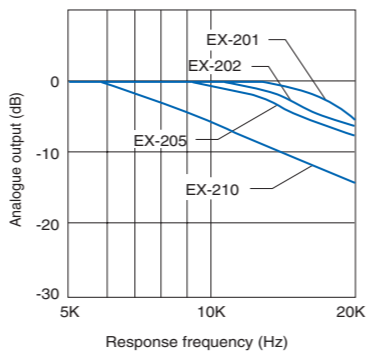

Response frequency vs. output characteristics (Typical)
Response frequency (all EX-200 models): LOW

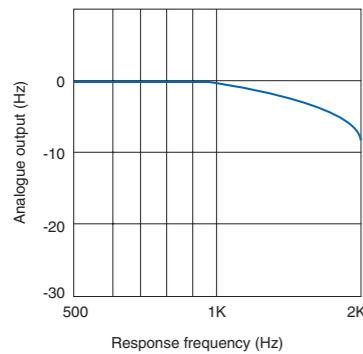

Output characteristics for nonferrous metal measurement (Typical)

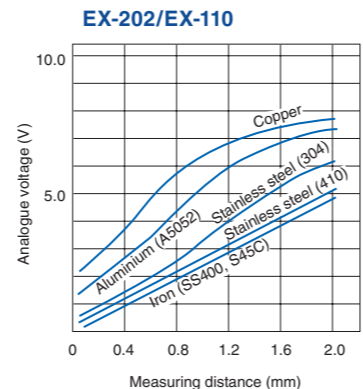
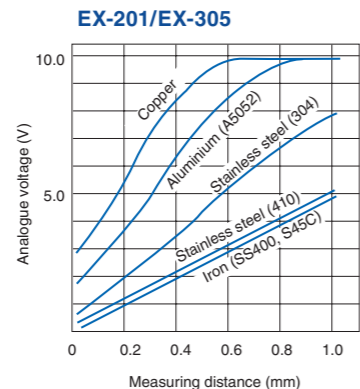

Output characteristics for nonferrous metal measurement (Typical)

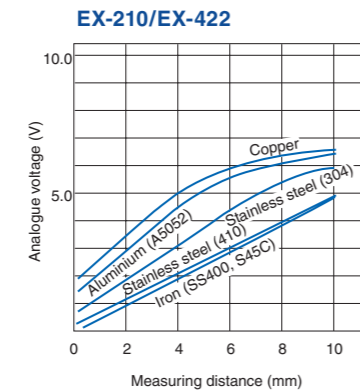
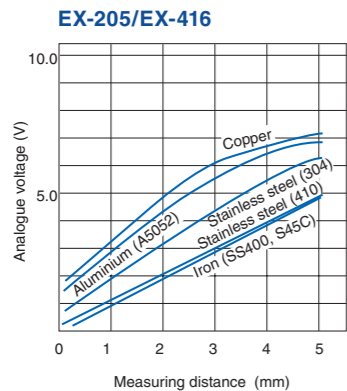

Hints on Correct Use

Compatibility

Since the controller and sensor head are factory-calibrated as a pair, check that they have the same serial number. If they do not have the same serial number, their characteristics may vary significantly.

Mounting

Tighten the EX-305 set screw and EX-110 nut away from the tip of the sensor head as shown in the figure.

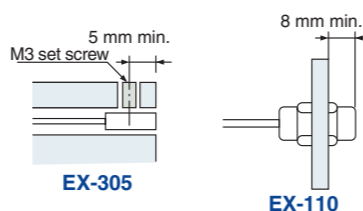

Flush-mounting

The diagram and table below shows the dimensions to use when flush-mounting a sensor head onto a metal plate.

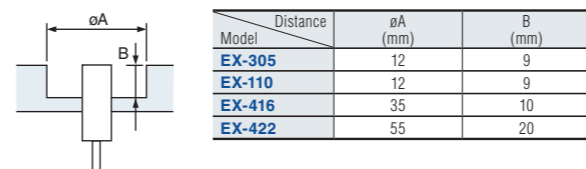

Mutual interference

When more than one of the same model sensor head are installed side by side, the sensors may not output the correct voltage due to mutual interference. Make sure that the distance between adjacent sensor heads is larger than the values shown below.

| Model | Distance | Parallel Installation (mm) |
|--------|----------|----------------------------|
| | Distance | |
| EX-305 | | 36 |
| EX-110 | | 80 |
| EX-416 | | 116 |
| EX-422 | | 142 |

Sensor head cable

The sensor head cable length should be 3 m. If you extend or cut the cable, its characteristics will change.

Dimensions

Unit: mm

Sensor heads

EX-305

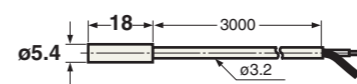

EX-110

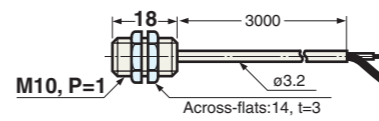

EX-416

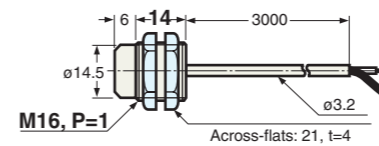

EX-422

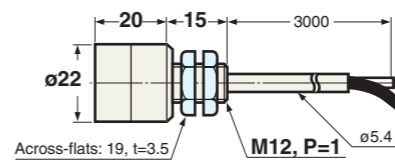

Controllers

EX-201/202/205/210

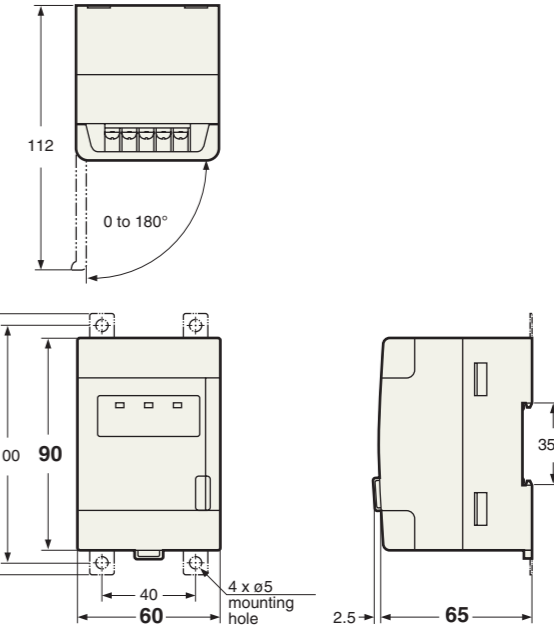

- Fibreoptic
- Photoelectric
- Proximity
- Area Sensor
- Pressure
- Multi Function**
- High Precision
- PLC/Touch Panel
- Static Elimination
- Vision System
- Laser Sensor
- Barcode
- Microscope

MULTI FUNCTION SELECTION GUIDE

CMOS LASER DISPLACEMENT
IL
IA

LASER
LB-1000
LB-70

THRUBEAM DIGITAL LASER
IG
IB

CONTACT
GT2
GT

ULTRASONIC
FW

INDUCTIVE
EX-V
EX-500
EX-200

ANALOGUE CONTROLLER
RD

POSITIONING
EG

SHOCK
GA

DOUBLE-FED
DD