

## Minor Loop Control Driver (for AC Power Supply)



### Features

- Optimize the control of minor feedback control type LEM※ valves by detecting the spool position with a differential transformer.
- The constant current characteristics suppress the power supply voltage fluctuation, and the output current fluctuation due to temperature rise of the solenoid, to almost zero.
- The output current waveforms (dither frequency, amplitude) are set to optimize the hysteresis and resolution of solenoid operated proportional control valves.
- The PWM (pulse width modulation) control of electrical current minimizes heat generation by the driver.

### Nomenclature

**KF** ※ - **5** - **10**  
1 2 1 3

**1 Model No.**

KF-5: Minor feedback control driver (for AC power supply)

**2 Applicable control valve**

No designation: LEM-G※※, LEMT-G03, LEMS-※※  
 H: LEMT-G04

**3 Design No. (The design No. is subject to change.)**

### Specifications

Model code		KF-5-10	KFH-5-10
Power supply voltage		AC 100, 200, 220 V (Common for 50 and 60 Hz)	
Permissible voltage fluctuation		-10 to +10%	
Applied load		Proportional solenoid (DC 24 V)	
Command input		DC 0 to 5 V or 1 kΩ potentiometer	
Output current		0 to 850 mA	0 to 1700 mA
Power consumption		62 VA	100 VA
Input impedance		70 ±5 kΩ	
Trimmer adjustment	MIN	0 to 2 V or more: Variable	
	MAX	5 to 1.9 V or less: Variable	
Dither selection		Selected among three kinds: high, medium and low, by changing the terminal connection	
Operating ambient temperature		0 to 55°C	
Operating ambient humidity		25 to 90%RH	
Mass		3.3 kg	

### Handling

- Terminals 5 and 6 are for connecting an ammeter. Short the terminals when not connecting an ammeter.
- Dither selection terminals 9 and 11 are shorted at shipment (medium setting). Shorting 9 and 10 results in greater dither effect (low setting) and shorting 9 and 12 results in less dither effect (high setting).
- Terminals 16 and 17 are shorted at shipment. Do not remove the pin for short.
- Terminal 23 is for checking the minor feedback voltage to detect the spool position.

# Contact Details

Before using the product, please check the guide pages at the front of this catalog.

Internet

<https://www.daikinpmc.com/en/>

For latest information, PDF catalogs and operation manuals

## External dimension diagram

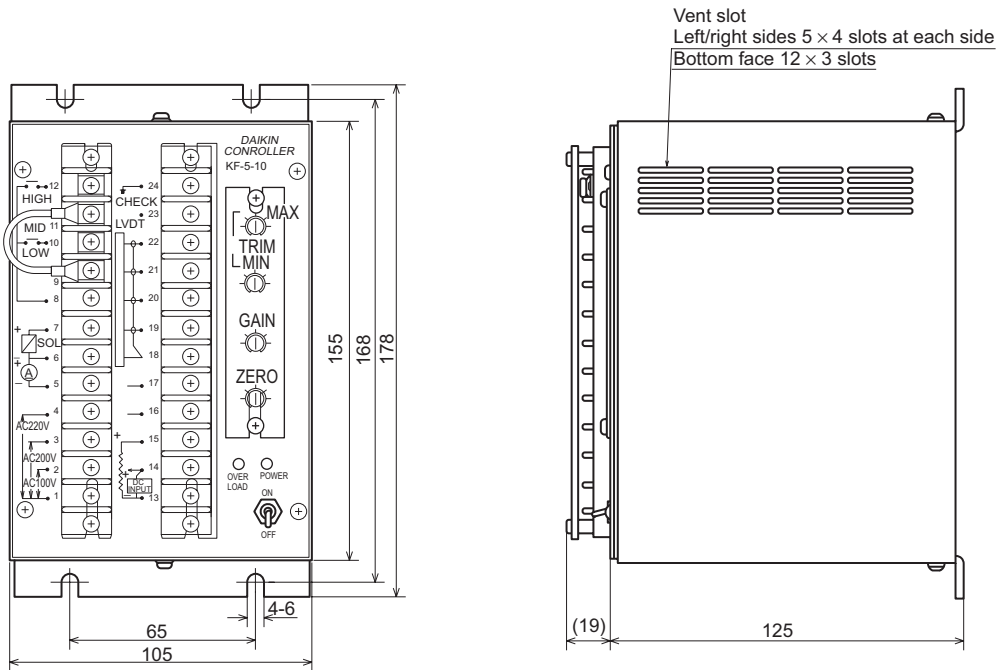

## Circuit configuration diagram

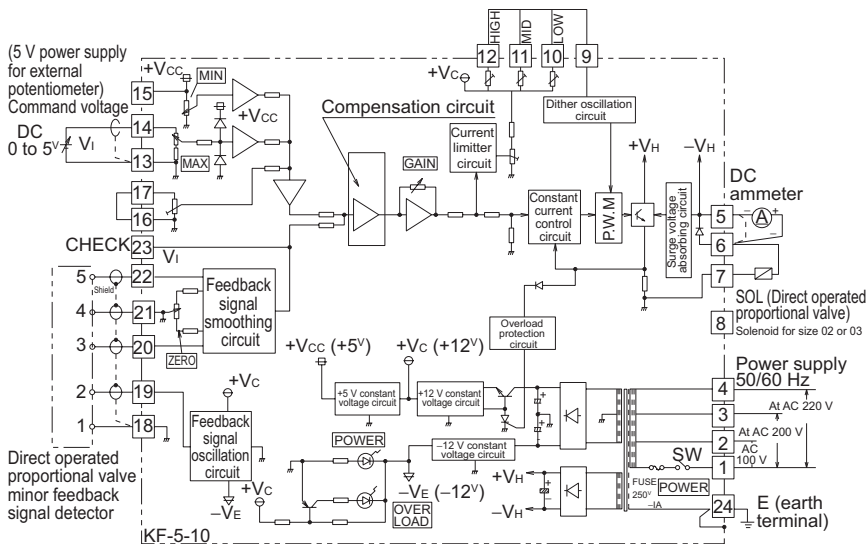

## Wiring diagram

