

4 Technical data



"Inverter Drives 8400" hardware manual

Here you can find the **ambient conditions** and information on the **electromagnetic compatibility (EMC)** which also apply to the communication module.

4.1 General data and operating conditions

Area	Values
Order designation	<ul style="list-style-type: none"> E84AYCPMV (coated version) E84AYCPMS (standard version)
Communication profile	<ul style="list-style-type: none"> PROFIBUS DP-V0 (DRIVECOM) PROFIBUS DP-V1 (PROFIdrive)
Communication medium	RS485
Interface	9-pin Sub-D socket
Network topology	<ul style="list-style-type: none"> Line (without repeater) Tree/line (with repeater)
Bus device type	PROFIBUS slave
Number of slaves	<ul style="list-style-type: none"> Max. 31 (without repeater) Max. 125 (with repeater)
Max. cable length	1200 m (depending on the selected baud rate and the cable type used)
PNO identification number	0x0A89
Baud rate for cable type A (EN 50170)	9.6 kbps ... 12 Mbps (automatic detection)
Conformities, approvals	<ul style="list-style-type: none"> CE UL

4.2 Protective insulation



Danger!

Dangerous voltage

If the Inverter Drives 8400 are used on a phase earthed mains with a rated mains voltage ≥ 400 V, protection against accidental contact is not ensured without implementing external measures.

Possible consequences:

Death or severe injury

Protective measures:

If protection against accidental contact is required for the control terminals of the inverter and the terminals of the plugged-in device modules, ...

- a double isolating distance must be provided.
- the components to be connected must be provided with a second isolating distance.



Note!

The existing protective insulation in the Inverter Drives 8400 is implemented according to EN 61800-5-1.

The following illustration ...

- shows the arrangement of the terminal strips and the separate potential areas of the Inverter Drives 8400.
- serves to determine the decisive protective insulation between two terminals located in differently insulated separate potential areas.

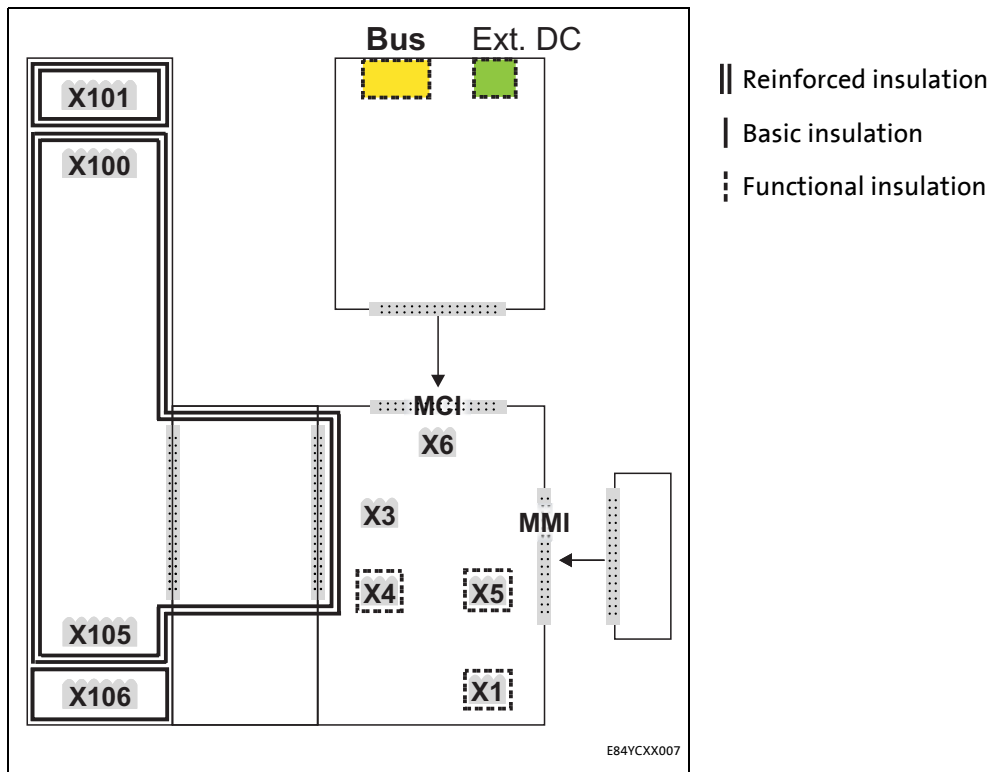

[4-1] Protective insulation in accordance with EN61800-5-1

Terminal strip	Connection
X100	Mains / DC bus connection
X101	Relay contact
X105	Motor/brake resistor
X106	Motor PTC
X1	System bus (CANopen)
X3	Analog inputs/outputs
X4	Digital outputs
X5	Digital inputs
X6	Diagnostics
MCI	Slot for communication module
MMI	Slot for memory module

Example

Which type of protective insulation is used between the bus terminal of the device module in the MCI slot and the mains terminal X100?

The separate potential area with the better protective insulation is decisive.

- The separate potential area of the device module's bus terminal is "functionally insulated".
- The separate potential area of the mains terminal has a "reinforced insulation".

Result: The insulation between the mains terminal X100 and the bus terminal is of the "reinforced insulation" type.

4 Technical data

4.3 Protocol data

4.3 Protocol data

Area	Values
Process data words (PCD)	1 ... 16 words (16 bits/word)
Cyclic parameter data channel (DP-V0)	4 words
Acyclic parameter data channel (DP-V1)	Max. 240 bytes
PROFIBUS user data length	1 ... 16 words process data channel + 4 words parameter data channel

4.4 Communication time

The communication time is the time between the start of a request and the arrival of the corresponding response.

The communication times in a PROFIBUS network depend on ...

- the processing time in the inverter;
- the transmission delay time (baud rate / telegram length);
- the nesting depth of the network.

Processing time in the inverter

Data	Processing time
Process data	Approx. 2 ms + 0 ... 1 ms + 1 ... x ms update cycle processing time in the module application task runtime of the technology application used (tolerance)
Parameter data	Approx. 30 ms + 20 ms tolerance (typical) For some codes, the processing time may be longer (see software manual// »Engineer« online help for Inverter Drives 8400).

There are no interdependencies between parameter data and process data.

4 Technical data

4.5 Dimensions

4.5 Dimensions

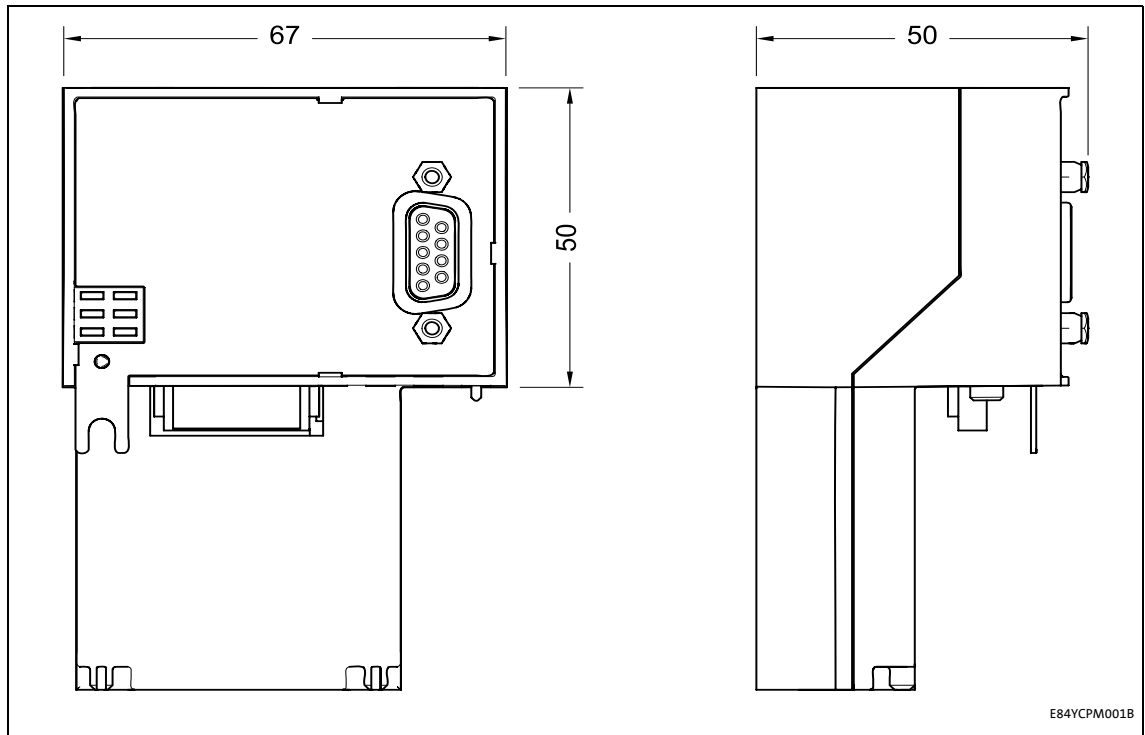

[4-2] Dimensions

Dimensions in mm

5 Installation



Stop!

Electrostatic discharge

Electronic components within the communication module can be damaged or destroyed by electrostatic discharge.

Possible consequences:

- The communication module is defective.
- Communication via the fieldbus is not possible or faulty.

Protective measures

Discharge electrostatic charges before touching the module.