

400/480V Frame 6 Drives

AC Precharge Board
SK-R9-PCG1-DF6

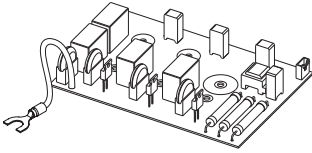

Step 2: See [page 3](#).

DC Precharge Board
SK-R9-PCG2-DF6

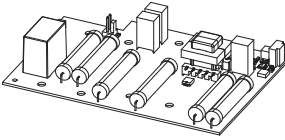

Step 2: See [page 3](#).

Power Interface Board

400V: SK-R9-PINT-CF6A, -CF6B, -CF6C, -CF6D
480V: SK-R9-PINT-DF6A, -DF6B, -DF6C, -DF6D

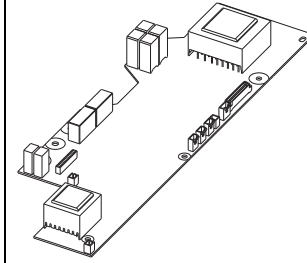

Step 2: See [page 4](#).

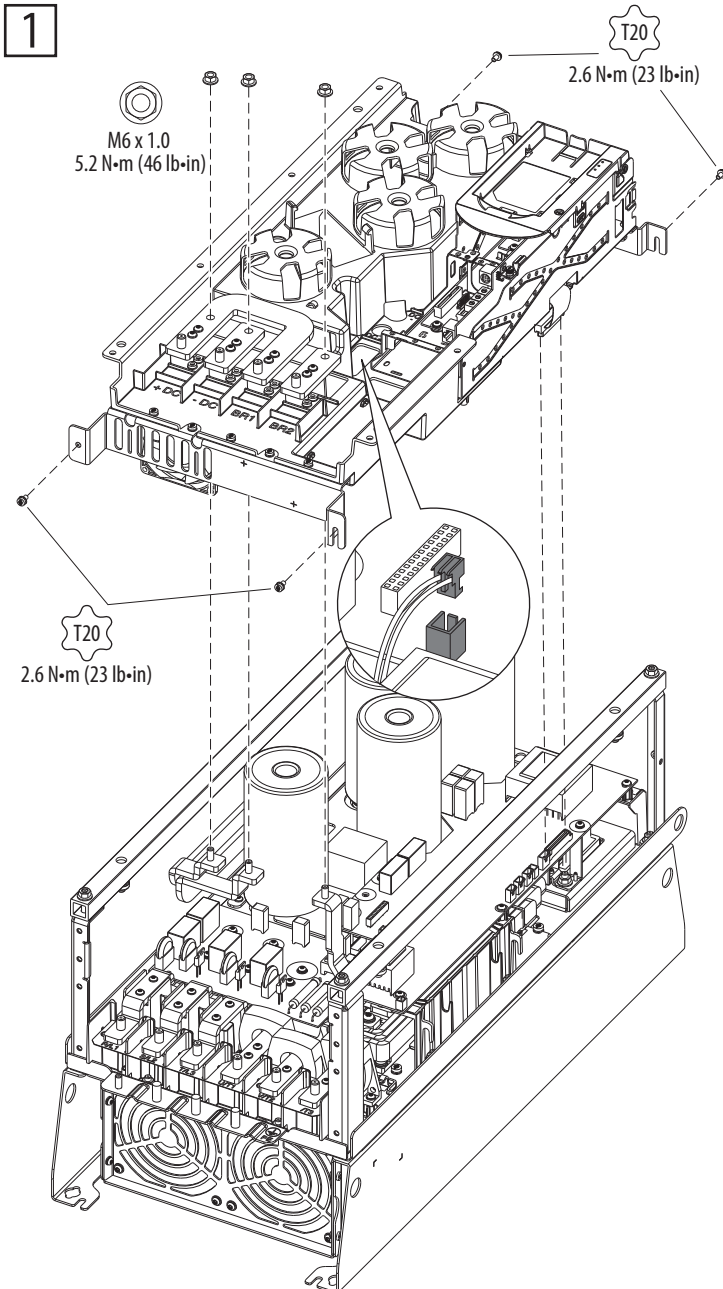

IMPORTANT: Power Jumpers may need to be removed during this procedure. Note where the PE-A and PE-B jumper wires are terminated before disassembly. Use the same position when installing the replacement board.

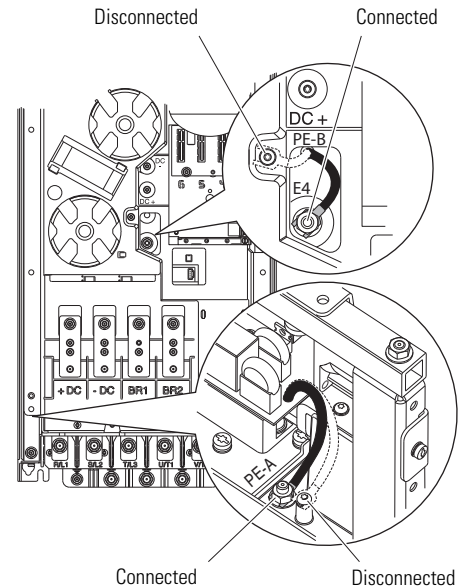

400/480V Frame 6 Drives – AC and DC Precharge Boards

SK-R9-PCG1-DF6, SK-R9-PCG2-DF6

2

IMPORTANT: Note the position of the PE-A jumper wire before disassembly (AC Precharge Boards only). Use the same position when installing the replacement board. Positions are identified in Step 1 on [page 2](#).

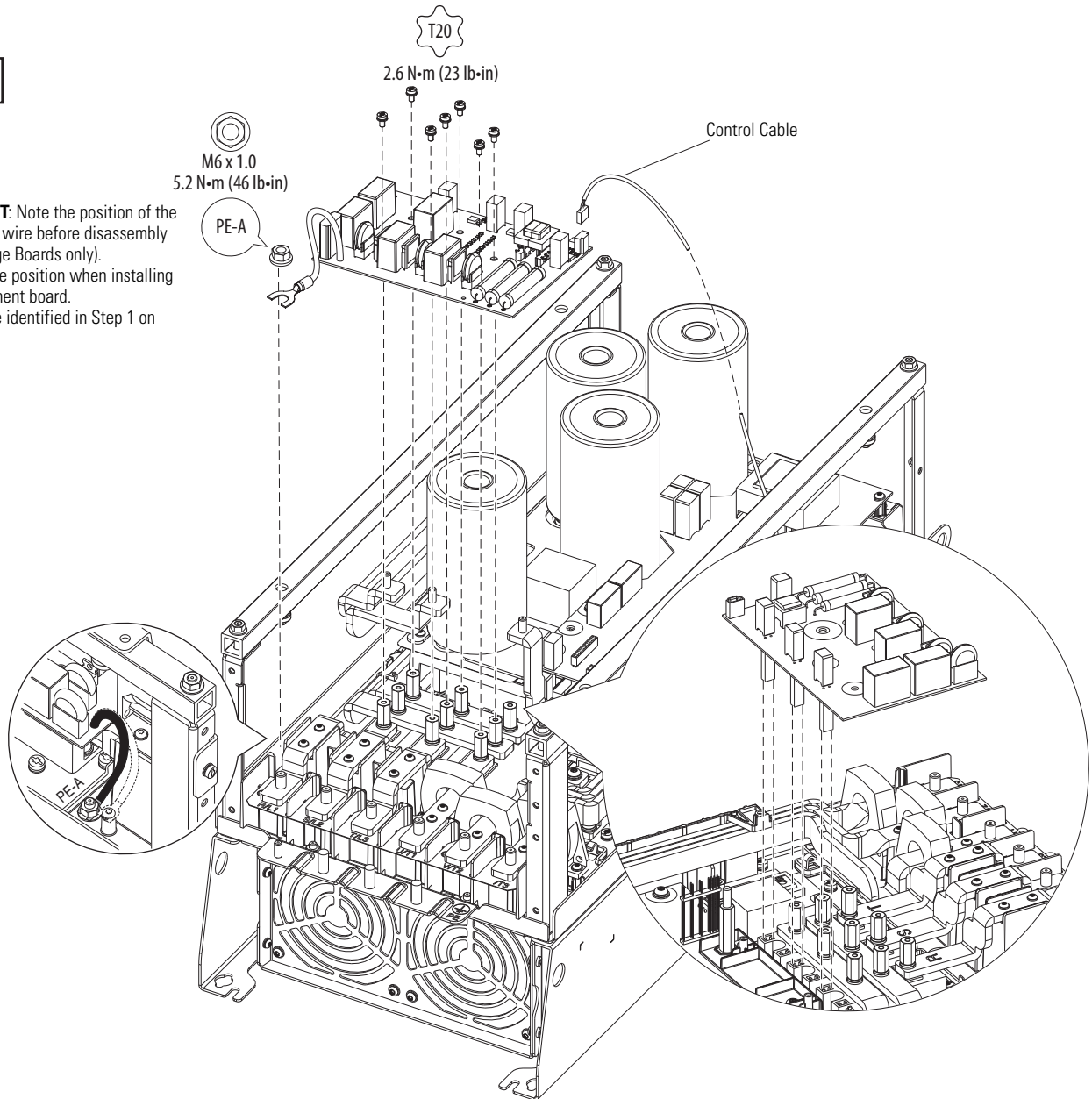

ATTENTION: Hazard of equipment damage exists if any board connector is not in full contact with its corresponding socket when power is applied. When installing the replacement board, carefully align and fully seat the pin connector(s), plug in the control cable, be sure the PE-A jumper wire is properly terminated (AC Precharge Boards only), and install all fasteners and torque as indicated.

400/480V Frame 6 Drives – Power Interface Board

400V: SK-R9-PINT1-CF6A, -CF6B, -CF6C, -CF6D / 480V: SK-R9PINT1-DF6A,-DF6B, -DF6C, -DF6D



ATTENTION: Replacing the Power Interface Board will result in the loss of drive data including elapsed power consumption, elapsed run times, and preventive maintenance data.

2

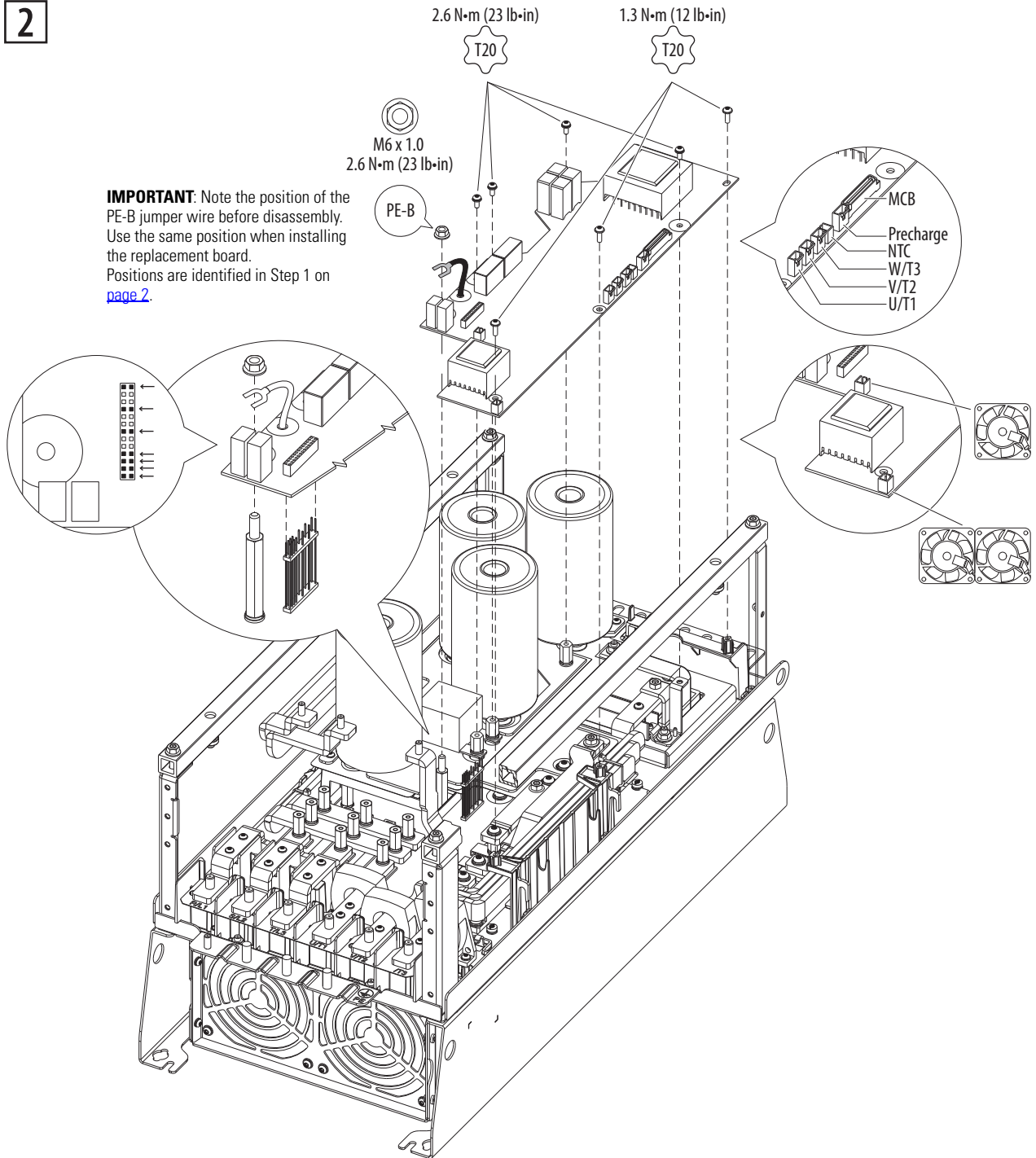

ATTENTION: Hazard of equipment damage exists if any board connector is not in full contact with its corresponding socket when power is applied. When installing the replacement board, be sure the pin connector is aligned, all plugs are fully seated, the PE-B jumper wire is properly terminated, and all fasteners are installed and torqued as indicated.

600/690V Frame 6 Drives

AC Precharge Board

SK-R9-PCG1-FF6

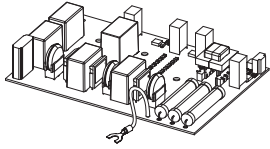

Step 2: See [page 6](#).

DC Precharge Board

SK-R9-PCG2-FF6

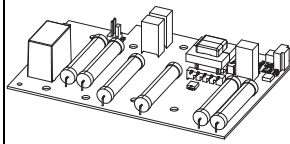

Step 2: See [page 6](#).

Power Interface Boards

600V: SK-R9-PINT1-EF6A, B, C, D, E, F, G, H, J, K, M, N, P

690V: SK-R9-PINT1-FF6A, B, C, D, E, F, G, H, J, K, L, M, N

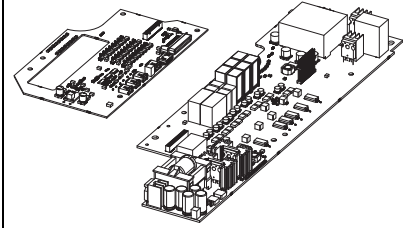

Step 2: See [page 7](#).

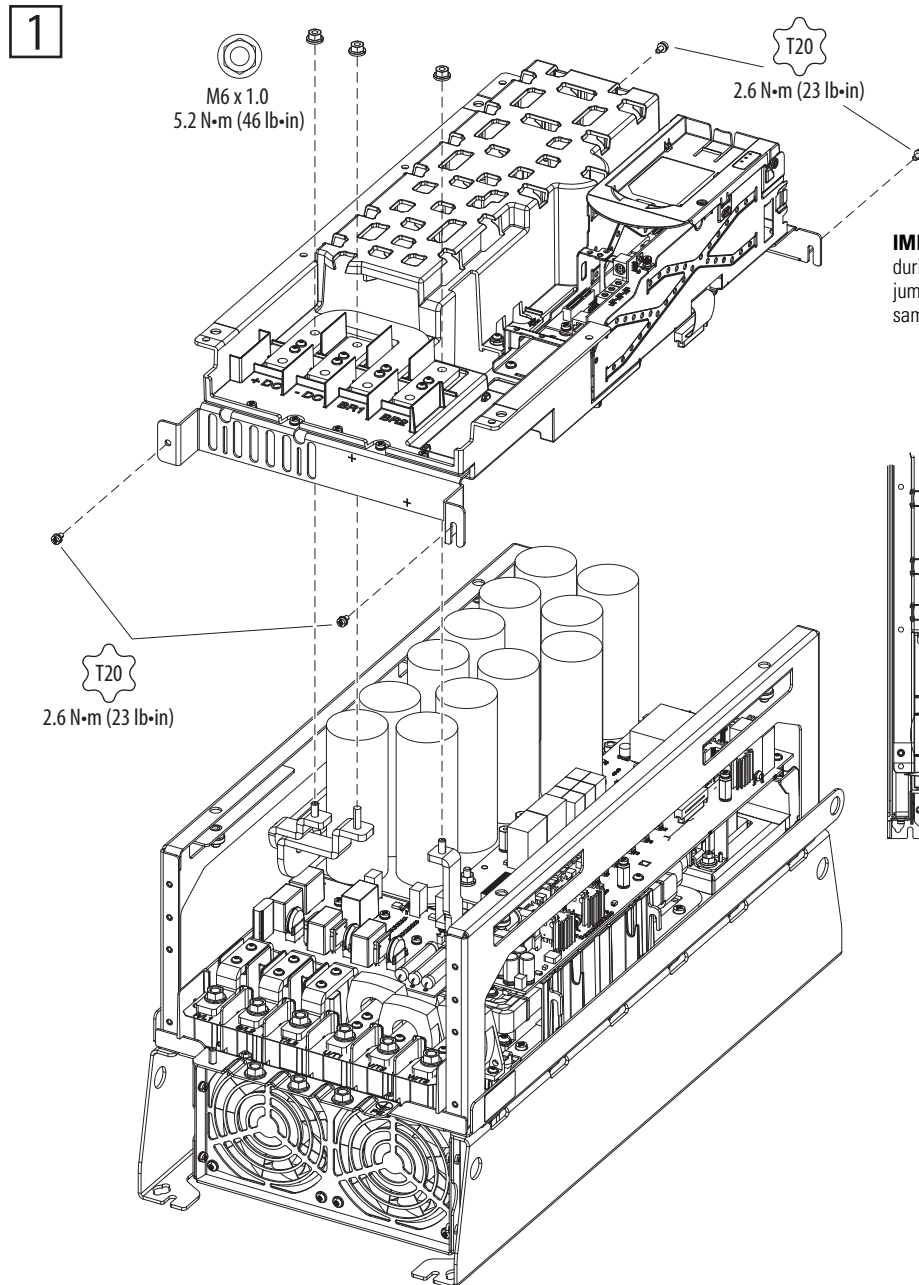

IMPORTANT: Power Jumpers may need to be removed during this procedure. Note where the PE-A and PE-B jumper wires are terminated before disassembly. Use the same position when installing the replacement board.

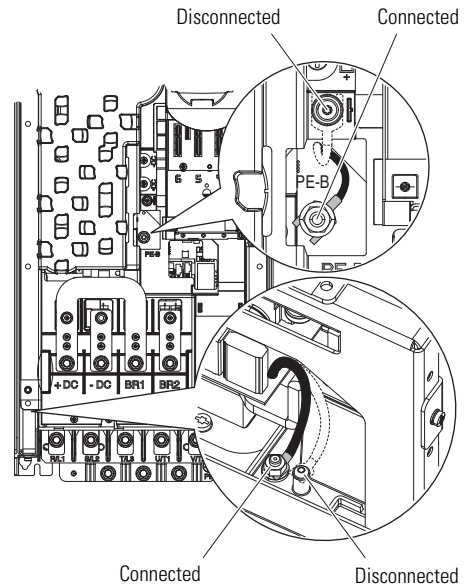

600/690V Frame 6 Drives – AC and DC Precharge Boards

SK-R9-PCG1-FF6, SK-R9-PCG2-FF6

2

IMPORTANT: Note the position of the PE-A jumper wire before disassembly (AC Precharge Boards only). Use the same position when installing the replacement board. Positions are identified in Step 1 on [page 5](#).

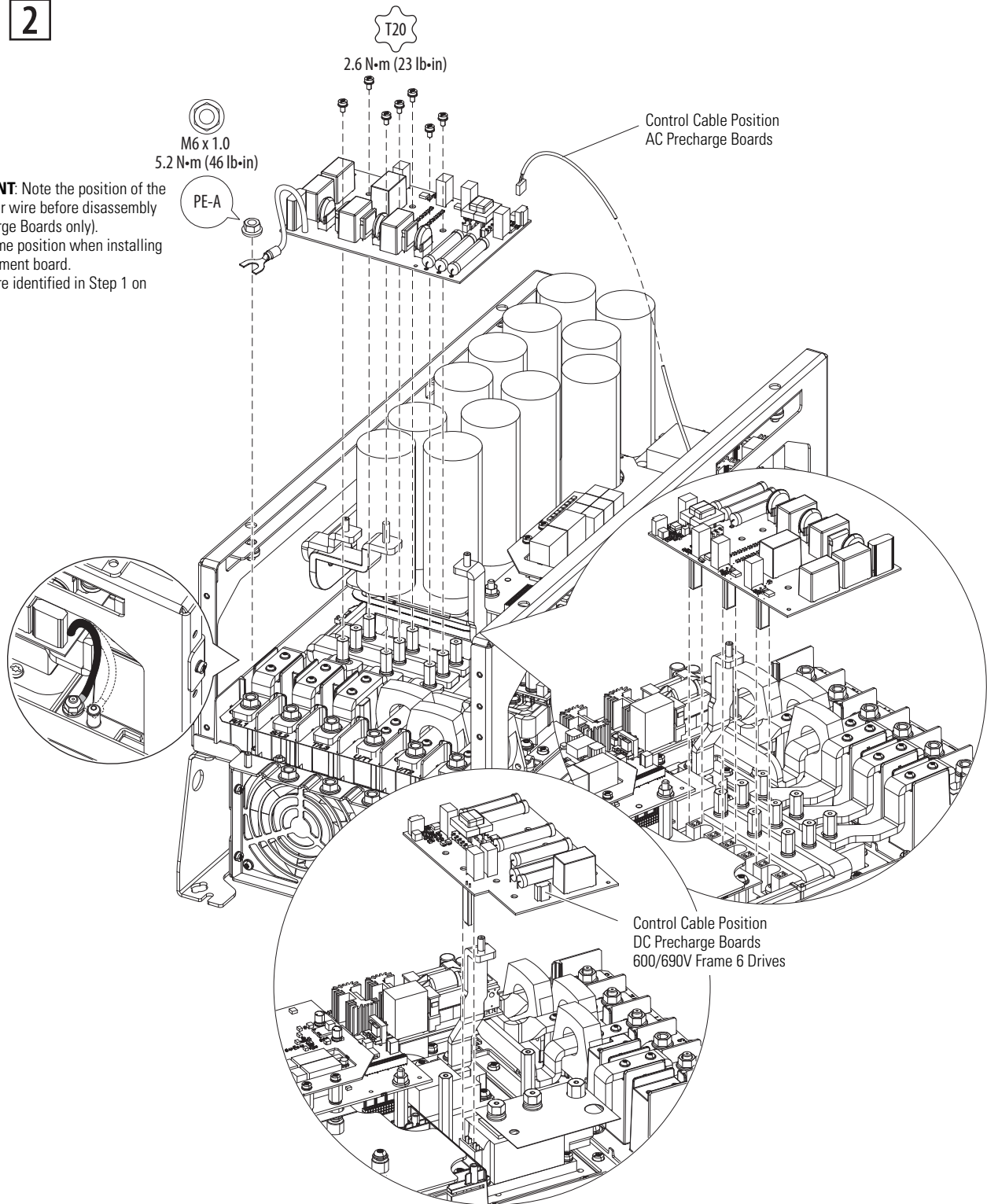

ATTENTION: Hazard of equipment damage exists if any board connector is not in full contact with its corresponding socket when power is applied. When installing the replacement board, carefully align and fully seat the pin connector(s), plug in the control cable, be sure the PE-A jumper wire is properly terminated (AC Precharge Boards only), and install all fasteners and torque as indicated.

600/690V Frame 6 Drives – Power Interface Boards

600V: SK-R9-PINT1-EF6A, -EF6B, -EF6C, -EF6D, -EF6E, -EF6F, -EF6G, -EF6H, -EF6J, -EF6K, -EF6M, -EF6N, -EF6P

690V: SK-R9-PINT1-FF6A, -FF6B, -FF6C, -FF6D, -FF6E, -FF6F, -FF6G, -FF6H, -FF6J, -FF6K, -FF6L, -FF6M, -FF6N

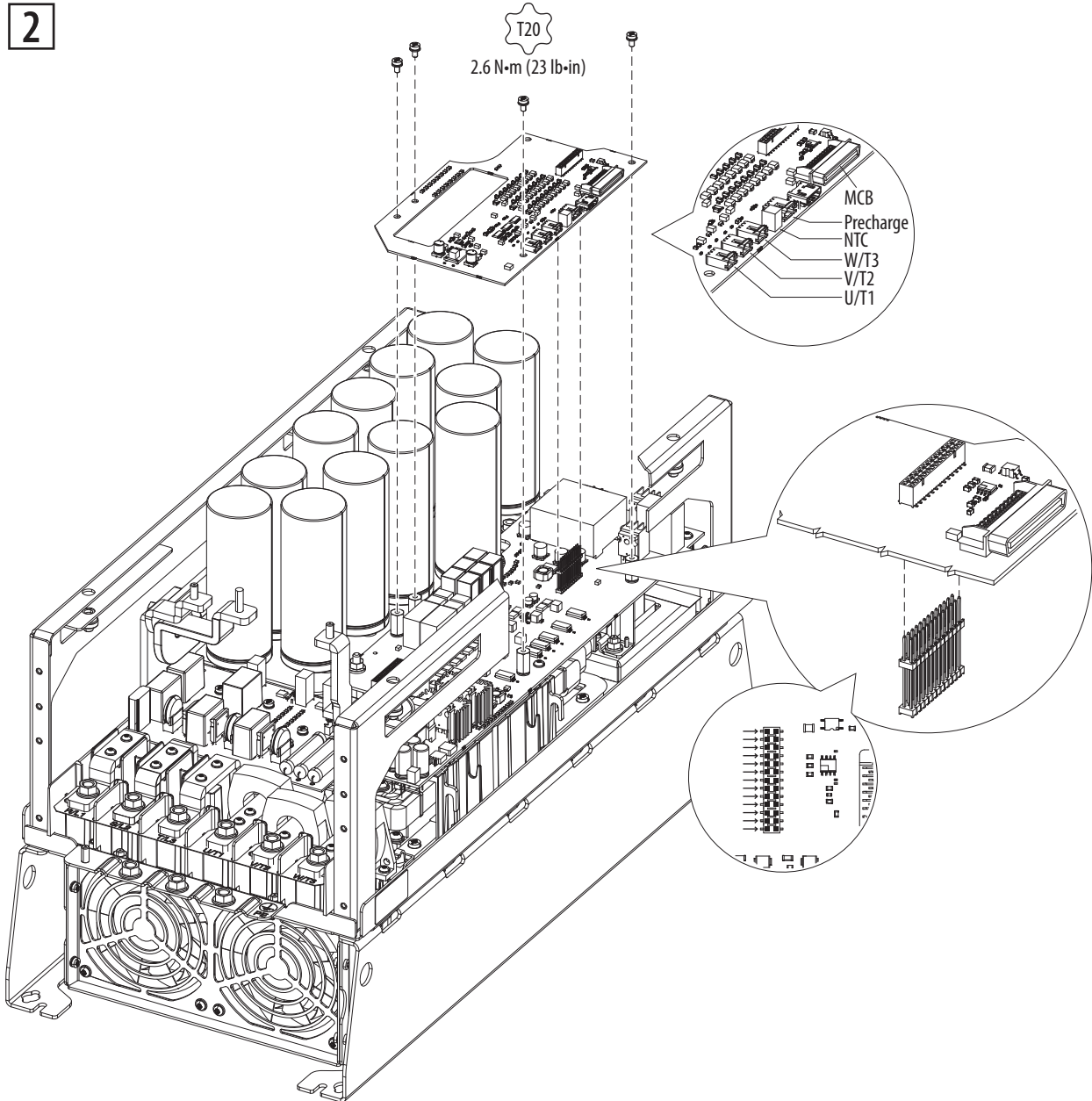

ATTENTION: Hazard of equipment damage exists if any board connector is not in full contact with its corresponding socket when power is applied. When installing the replacement board, be sure the pin connector is aligned and all plugs are fully seated.

600/690V Frame 6 Drives – Power Interface Boards (Continued)



ATTENTION: Replacing the Power Interface Boards will result in the loss of drive data including elapsed power consumption, elapsed run times, and preventive maintenance data.

3

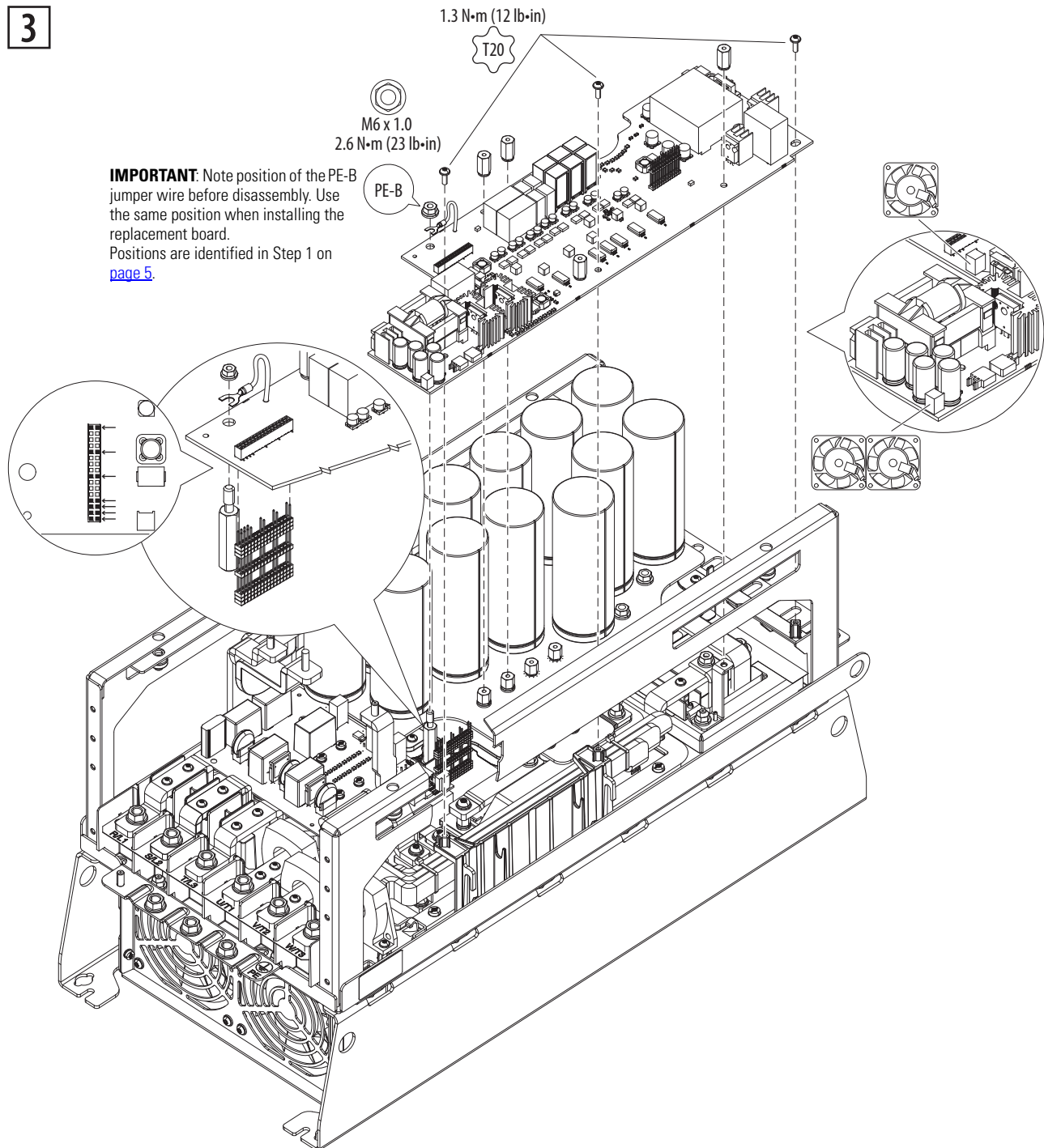

ATTENTION: Hazard of equipment damage exists if any board connector is not in full contact with its corresponding socket when power is applied. When installing the replacement board, be sure the pin connector is aligned, all plugs are fully seated, the PE-B jumper wire is properly terminated, and all fasteners are installed and torqued as indicated.

400/480V Frame 7 Drives

AC Precharge Board
SK-R9-PCG1-DF7

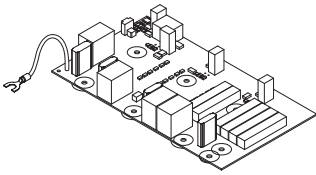

Step 2: See [page 10](#).

DC Precharge Board
SK-R9-PCG2-DF7

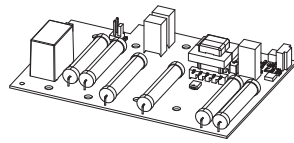

Step 2: See [page 10](#)

Power Interface Board

400V: SK-R9-PINT1-CF7A, -CF7B, -CF7C
480V: SK-R9-PINT1-DF7A, -DF7B, -DF7C

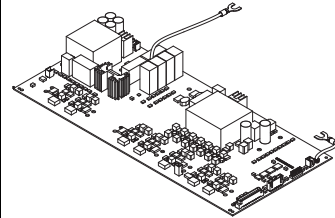

Step 2: See [page 10](#)

1

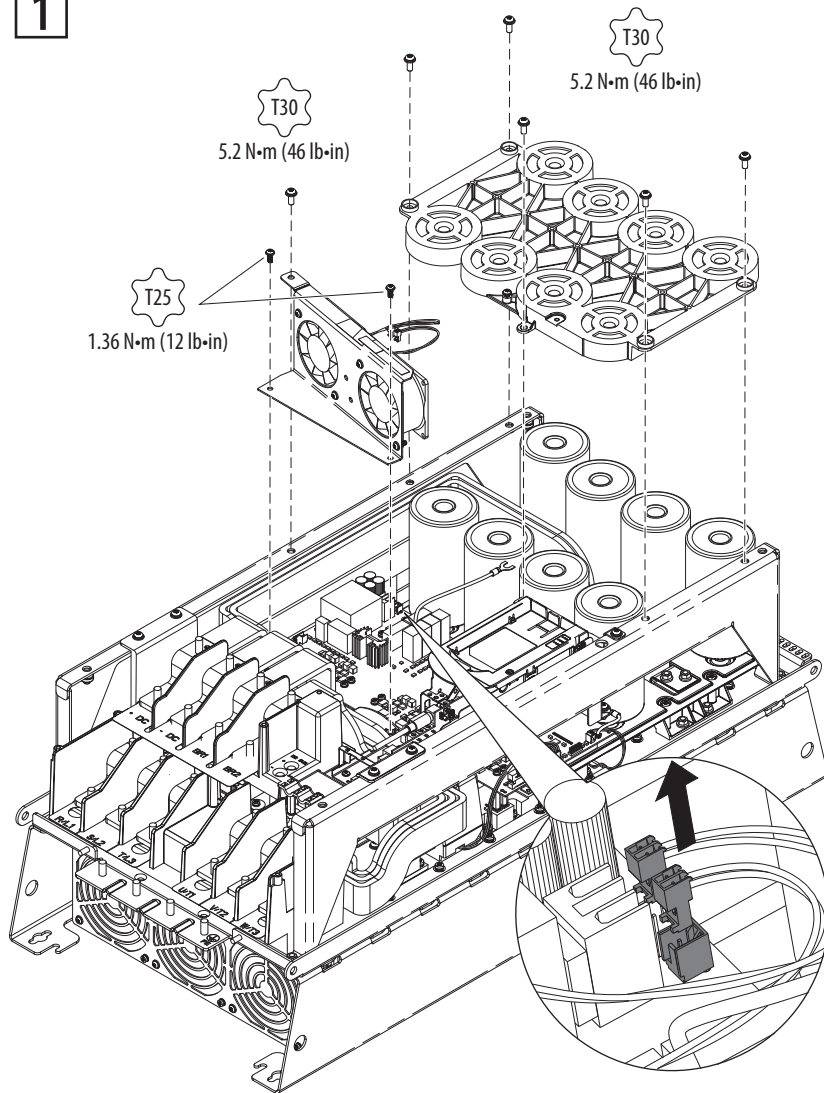

IMPORTANT: Power Jumpers may need to be removed during this procedure. Note where the PE-A and PE-B jumper wires are terminated before disassembly. Use the same position when installing the replacement board.

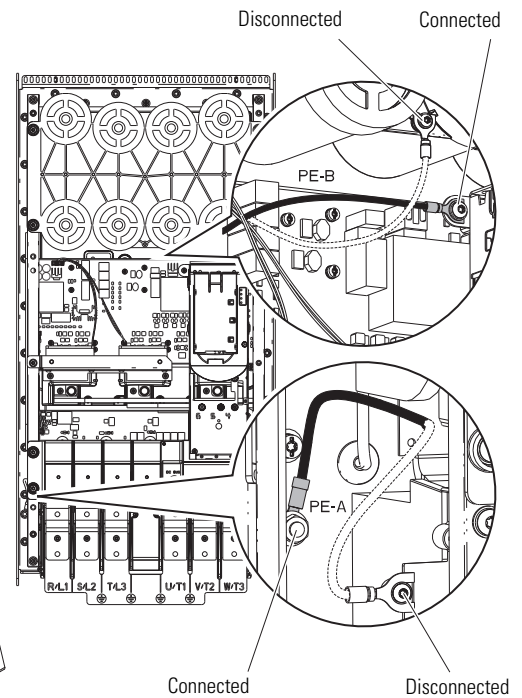

400/480V Frame 7 Drives – AC and DC Precharge Boards

SK-R9-PCG1-DF7, SK-R9-PCG2-DF7

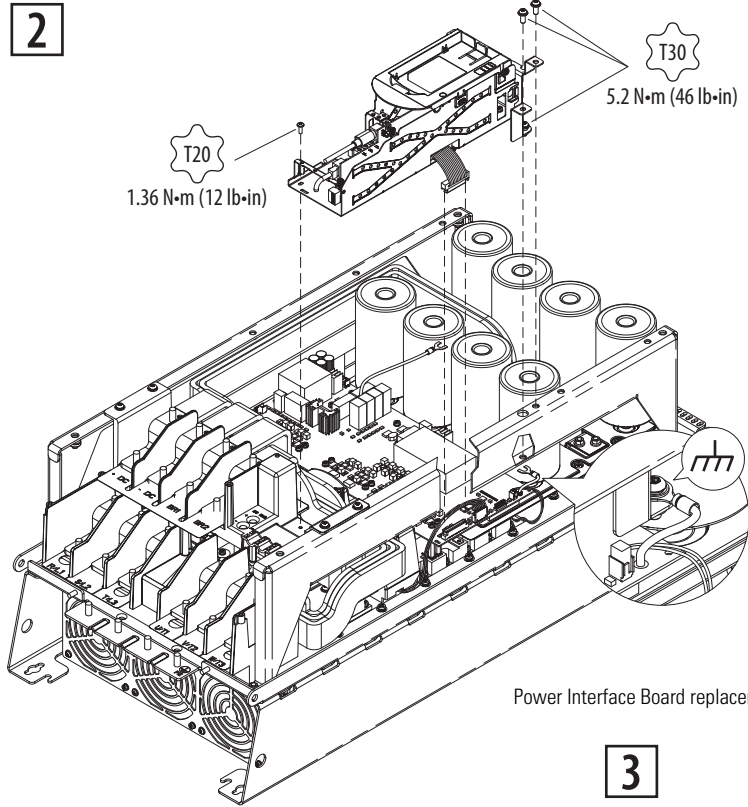

Power Interface Board replacement go to Step 3 on [page 12](#).

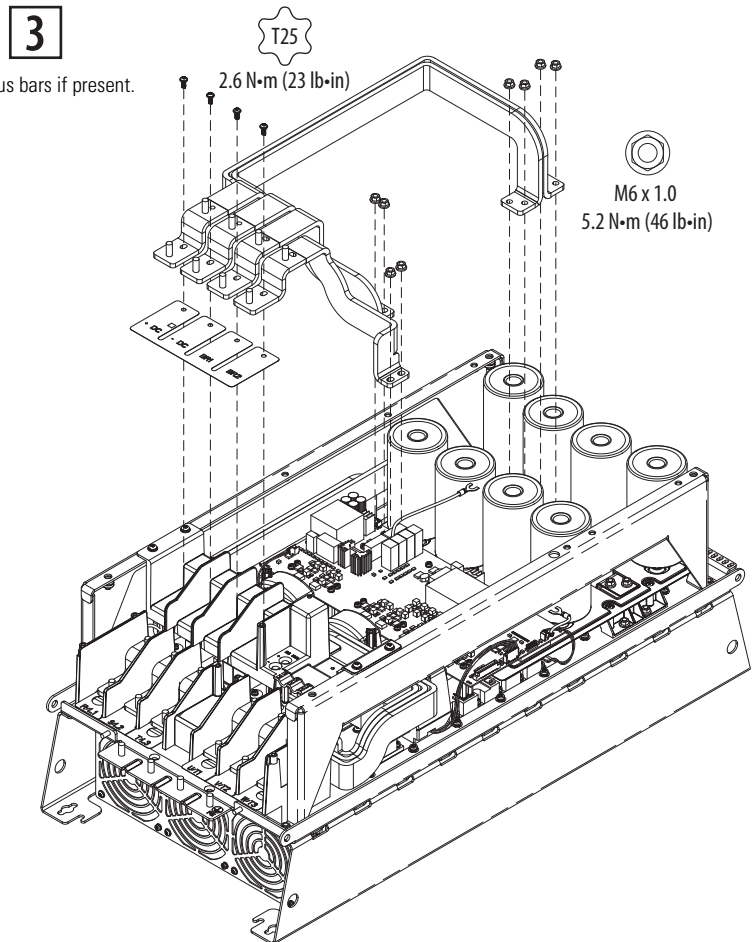

400/480V Frame 7 Drives – AC and DC Precharge Boards (Continued)

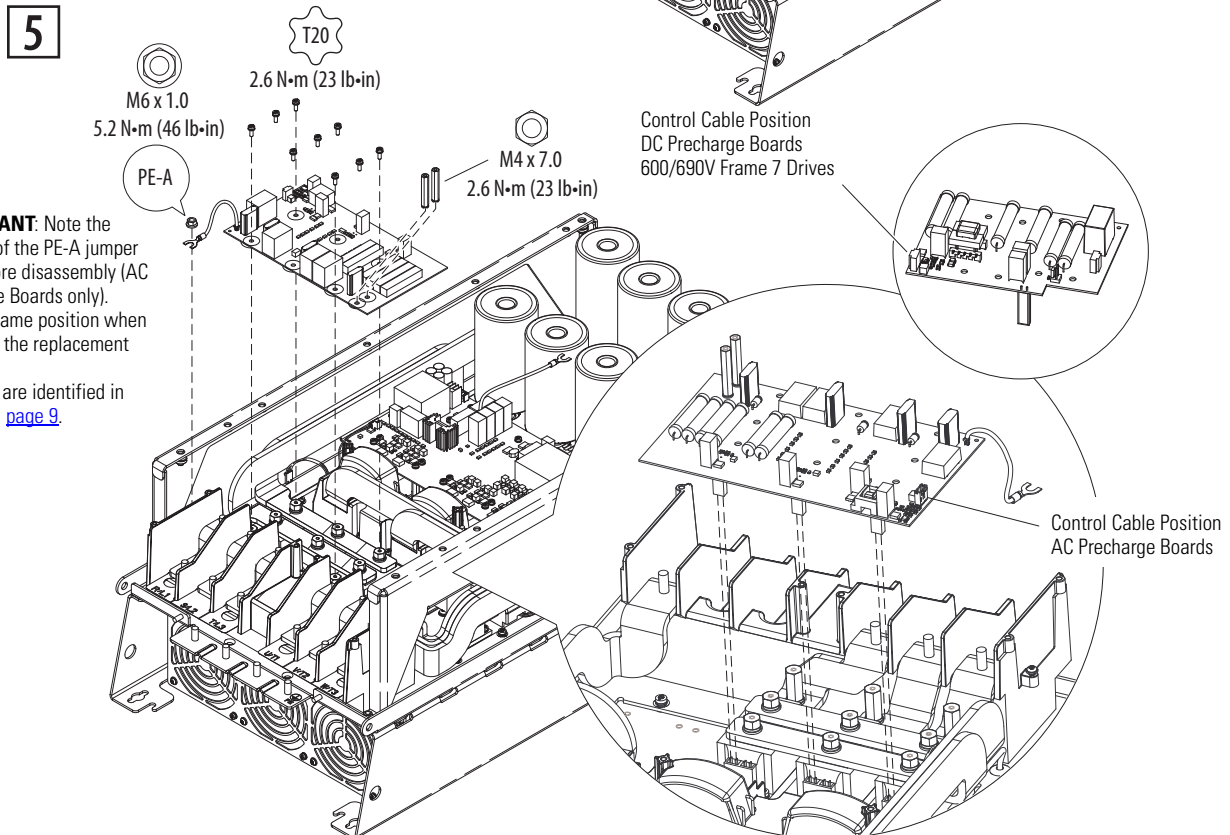
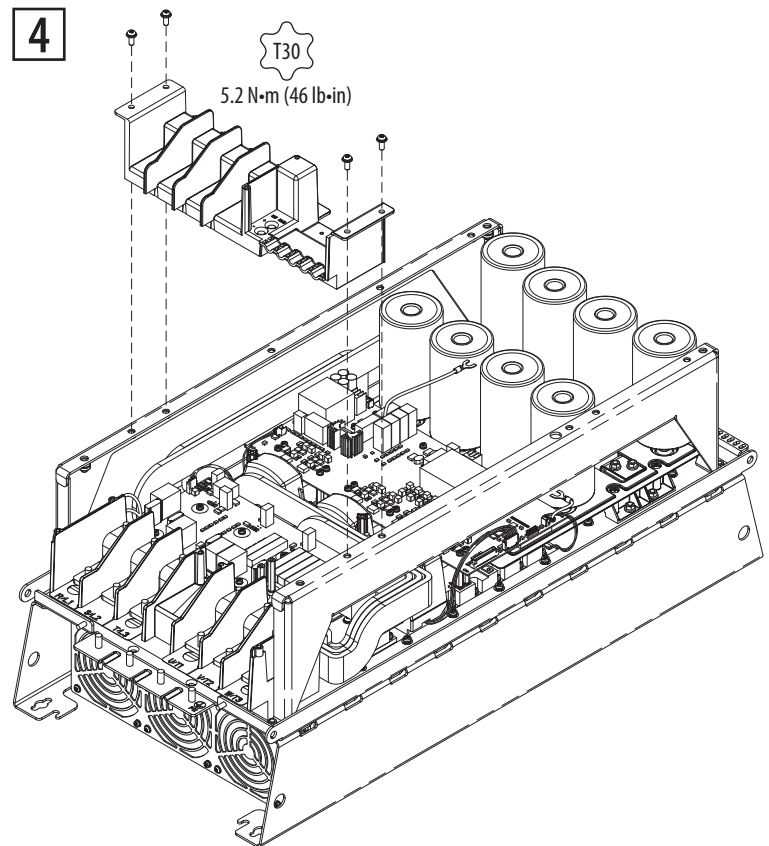

IMPORTANT: Note the position of the PE-A jumper wire before disassembly (AC Precharge Boards only). Use the same position when installing the replacement board. Positions are identified in Step 1 on [page 9](#).



ATTENTION: Hazard of equipment damage exists if any board connector is not in full contact with its corresponding socket when power is applied. When installing the replacement board, carefully align and fully seat the pin connector(s), plug in the control cable, be sure the PE-A jumper wire is properly terminated (AC Precharge Boards only), and install all fasteners and torque as indicated.

400/480V Frame 7 Drives – Power Interface Board

400V: SK-R9-PINT1-CF7A, -CF7B, -CF7C

480V: SK-R9-PINT1-DF7A, -DF7B, -DF7C



ATTENTION: Replacing the Power Interface Board will result in the loss of drive data including elapsed power consumption, elapsed run times, and preventive maintenance data.

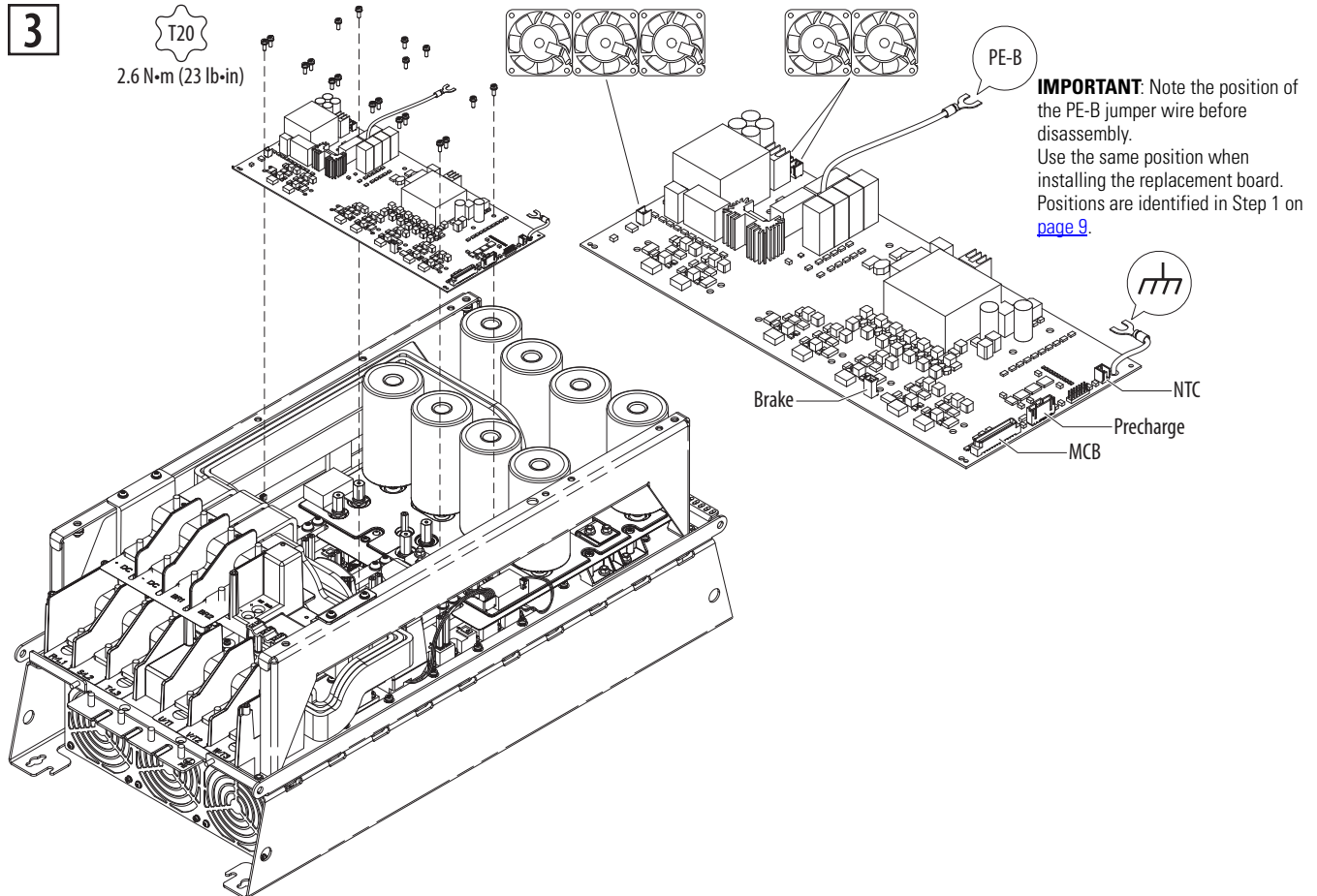

ATTENTION: Hazard of equipment damage exists if any board connector is not in full contact with its corresponding socket when power is applied. When installing the replacement board, be sure the pin connector is aligned, all plugs are fully seated, the PE-B jumper wire is properly terminated, and all fasteners are installed and torqued as indicated.

600/690V Frame 7 Drives

AC Precharge Board

SK-R9-PCG1-FF7

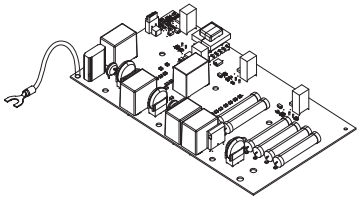

Steps 2: See [page 14](#).

DC Precharge Board

SK-R9-PCG2-FF7

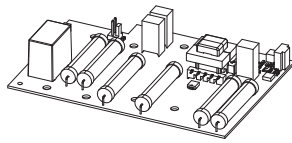

Step 2: See [page 14](#).

Power Interface Board

600V: SK-R9-PINT1-EF7A, -EF7B, -EF7C

690V: SK-R9-PINT1-FF7A, -FF7B, -FF7C

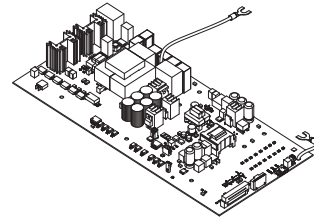

Step 2: See [page 14](#).

IMPORTANT: Power Jumpers may need to be removed during this procedure. Note where the PE-A and PE-B jumper wires are terminated before disassembly. Use the same position when installing the replacement board.

1

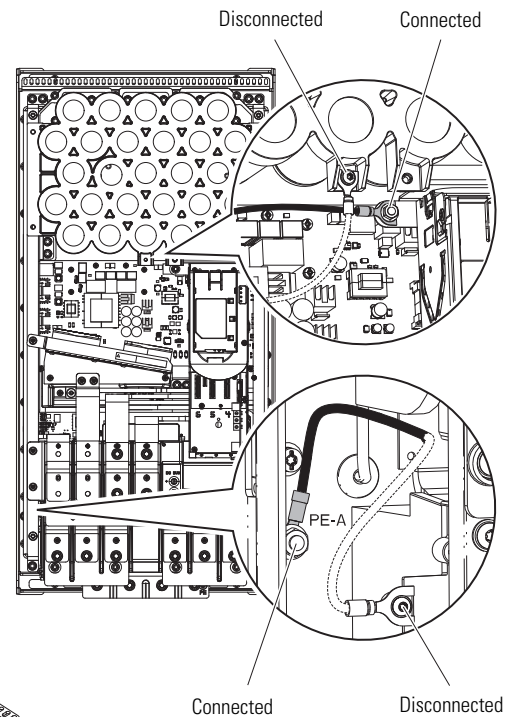
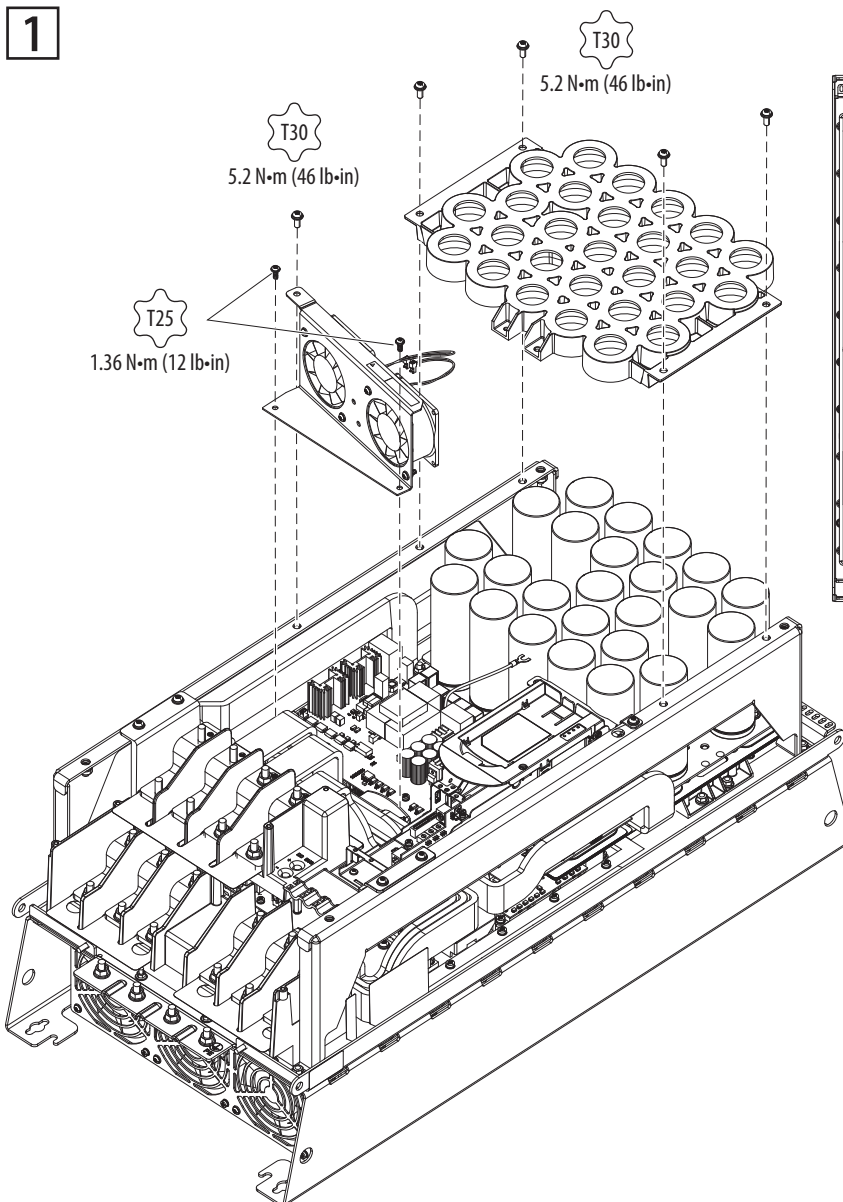

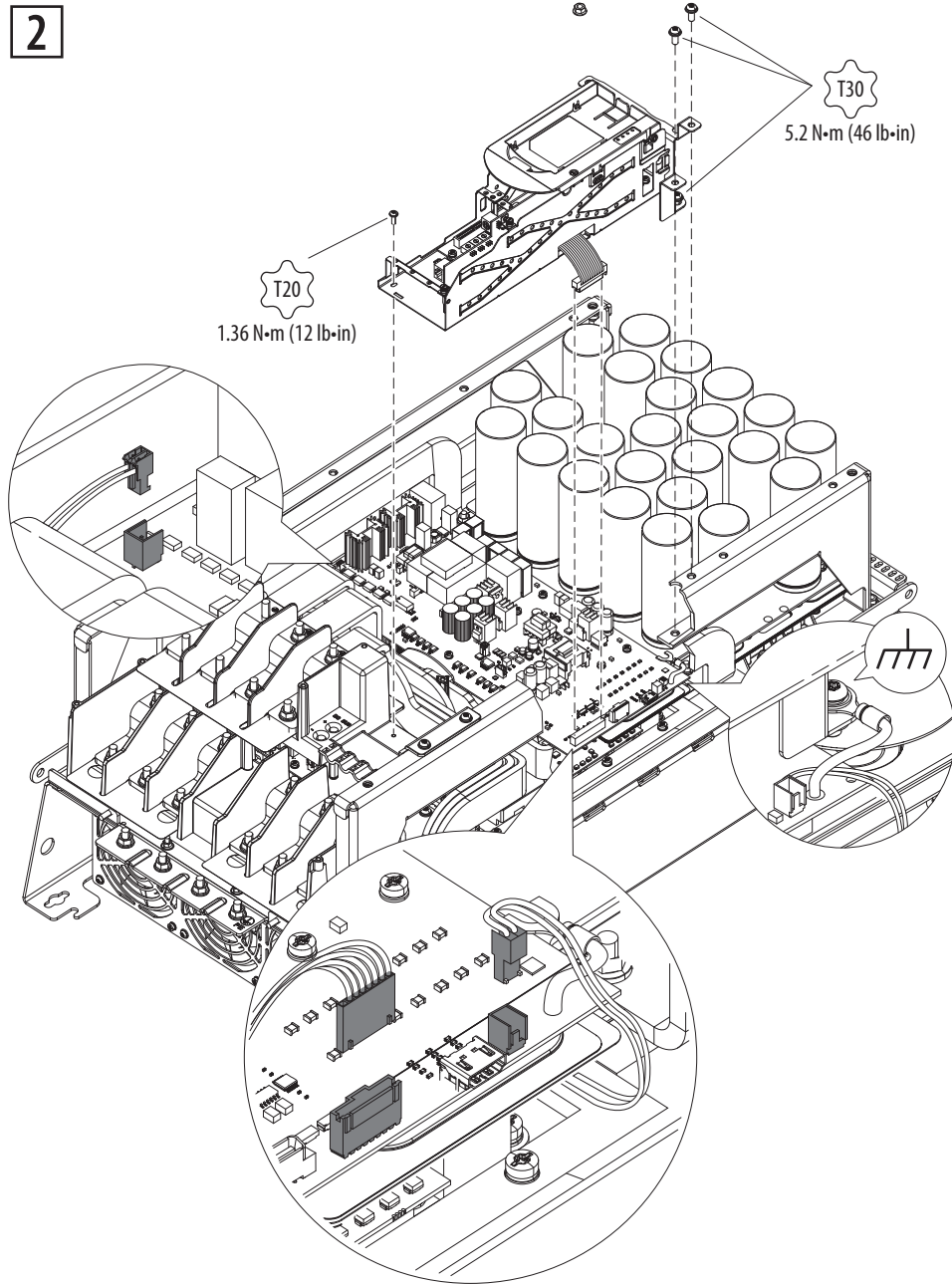
600/690V Frame 7 Drives (Continued)

Precharge Board replacement go to Step 3 on [page 15](#).
Power Interface Board replacement go to Step 3 on [page 17](#).

600/690V Frame 7 Drives – AC and DC Precharge Board

SK-R9-PCG1-FF7, SK-R9-PCG2-FF7

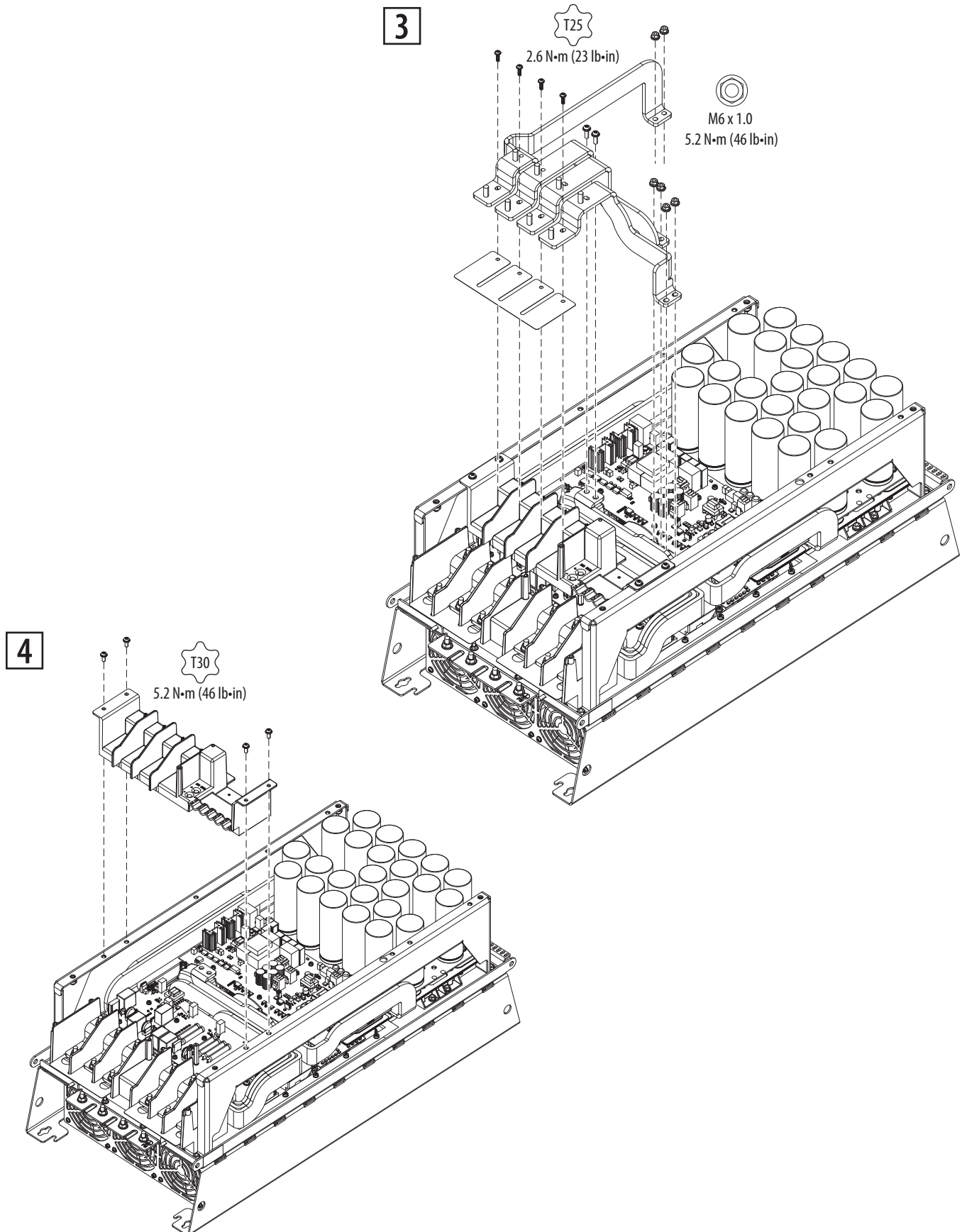

600/690V Frame 7 Drives – AC and DC Precharge Board (Continued)

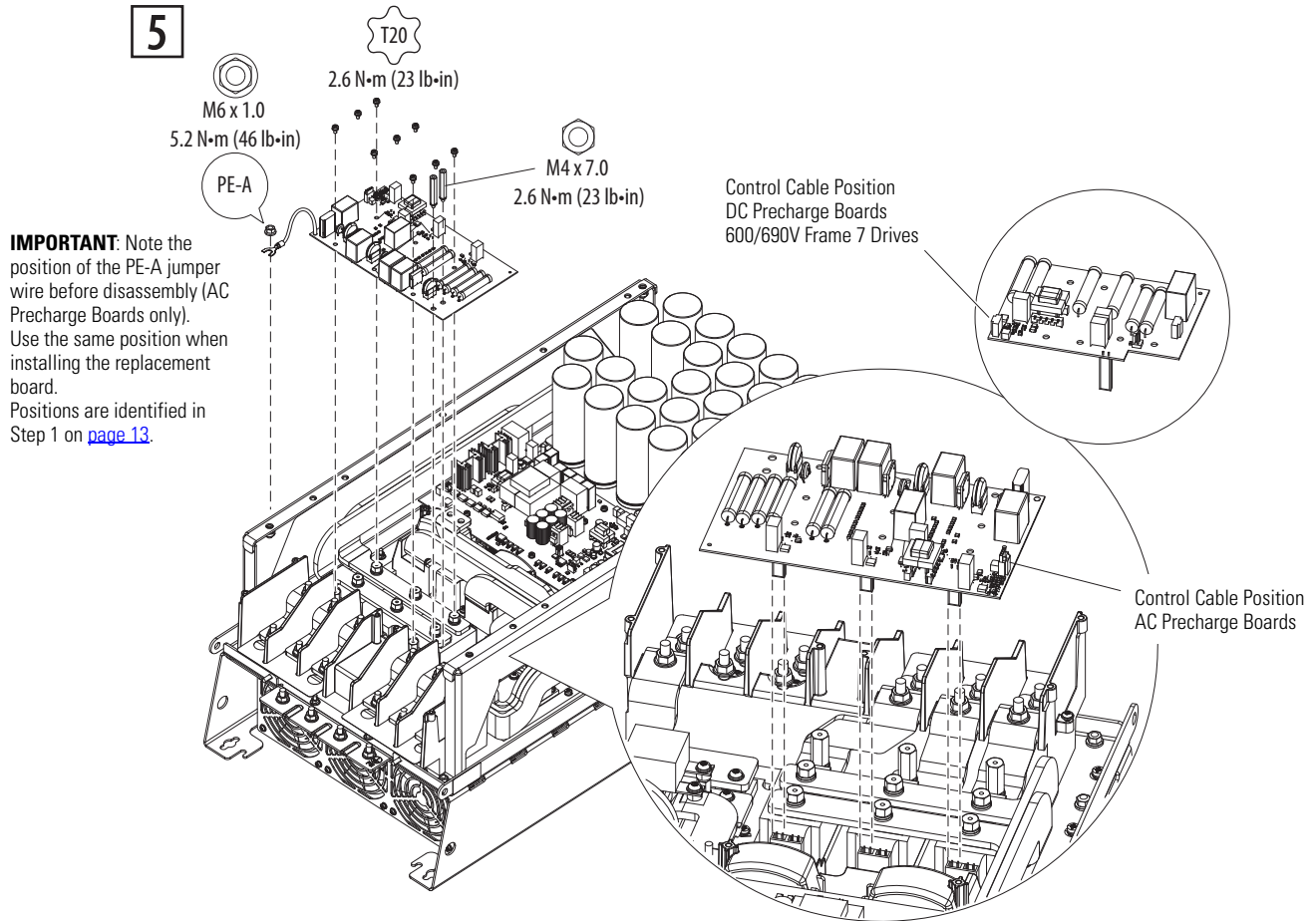

ATTENTION: Hazard of equipment damage exists if any board connector is not in full contact with its corresponding socket when power is applied. When installing the replacement board, carefully align and fully seat the pin connector(s), plug in the control cable, be sure the PE-A jumper wire is properly terminated (AC Precharge Boards only), and install all fasteners and torque as indicated.

600/690V Frame 7 – Power Interface Board

600V: SK-R9-PINT1-EF7A, -EF7B, -EF7C

690V: SK-R9-PINT1-FF7A, -FF7B, -FF7C



ATTENTION: Replacing the Power Interface Board will result in the loss of drive data including elapsed power consumption, elapsed run times, and preventive maintenance data.

3

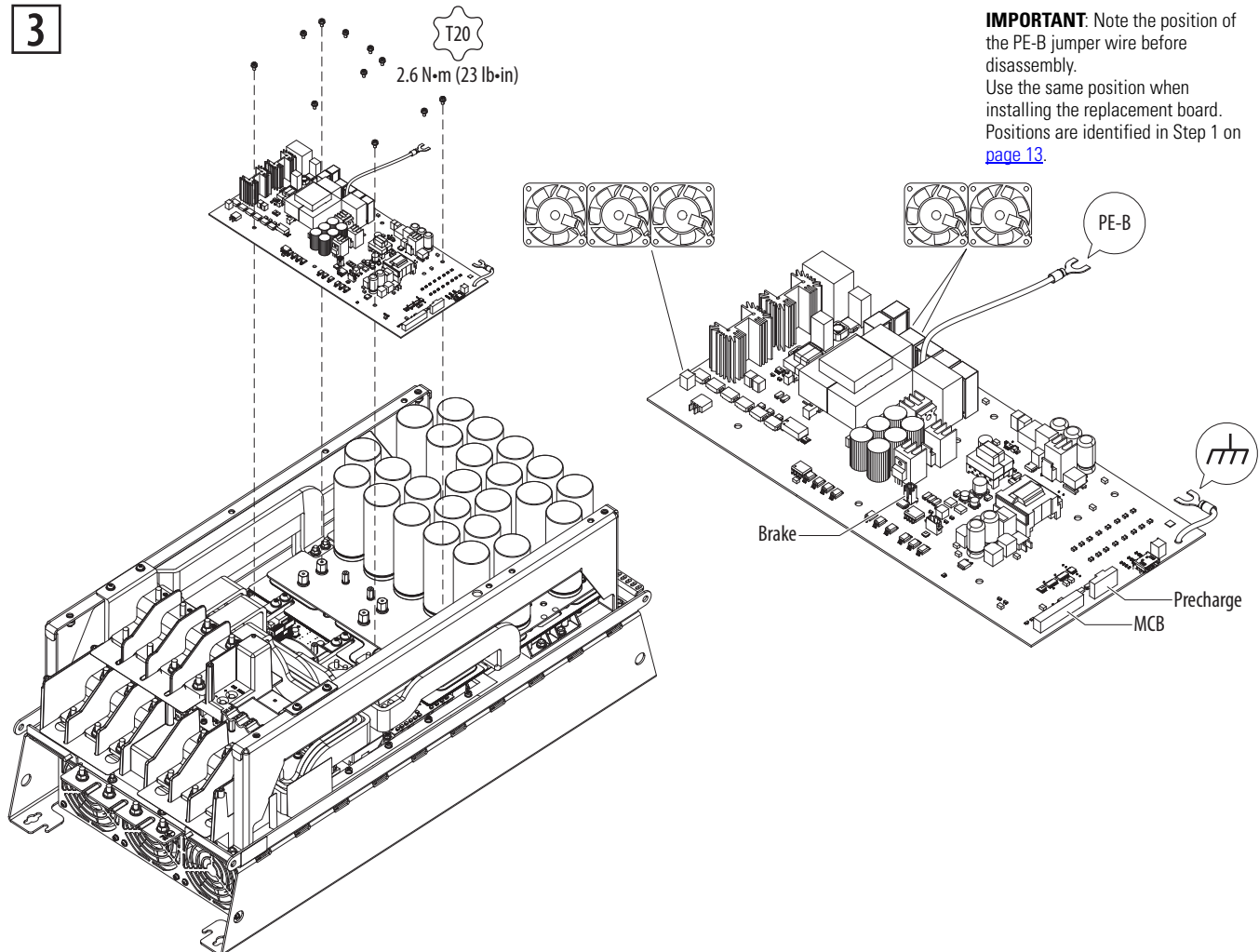

ATTENTION: Hazard of equipment damage exists if any board connector is not in full contact with its corresponding socket when power is applied. When installing the replacement board, be sure the pin connector is aligned, all plugs are fully seated, the PE-B jumper wire is properly terminated, and all fasteners are installed and torqued as indicated.