

Overview

The FLEX™ I/O digital sourcing input and sinking output modules mount on a FLEX I/O terminal base.

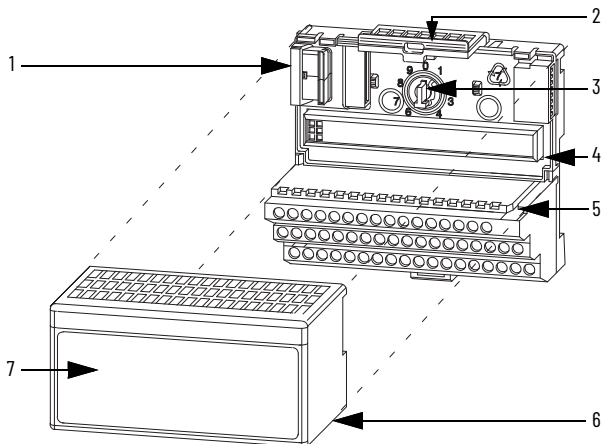

	Description		Description
1	Flexbus connector	5	Groove
2	Latching mechanism	6	Alignment bar
3	Keyswitch	7	Module
4	Terminal base		

Install Your Module



ATTENTION: During mounting of all devices, be sure that all debris (metal chips, wire strands, and so on) is kept from falling into the module. Debris that falls into the module could cause damage on power-up.

1. Rotate the keyswitch (3) on the terminal base (4) clockwise to position 2 as required for this type of module.
2. Make sure the Flexbus connector (1) is pushed all the way to the left to connect with the adjacent terminal base or adapter. **You cannot install the module unless the connector is fully extended.**
3. Make sure that the pins on the bottom of the module are straight so that they align properly with the connector in the terminal base.
4. Position the module (7) with its alignment bar (6) aligned with the groove (5) on the terminal base.
5. Press firmly and evenly to seat the module in the terminal base unit. The module is seated when the latching mechanism (2) is locked into the module.

Connect Wiring for the 1794-IV32 Module

Mount the 1794-IV32 module on a 1794-TB32 or 1794-TB32S terminal base.

1. Connect individual input wiring (0...15) to numbered terminals on the 0...15 row (A) as indicated in [Table 1](#).
2. Connect the associated power to the +V1 terminal (35, 37, 39, or 41) on the 34...51 row (C) as indicated in [Table 1](#).
3. Connect the associated common for inputs 0...15 to COM1 (terminal 36, 38, 40, or 42) on the 34...51 row (C) as indicated in [Table 1](#).
4. Connect individual input wiring (16...31) to numbered terminals on the 16...33 row (B) as indicated in [Table 1](#). **Do not connect to terminals 16 or 33.**
5. Connect the associated power to the +V2 terminal (43, 45, 47, or 49) on the 34...51 row (C) as indicated in [Table 1](#).
6. Connect the associated common for inputs 16...31 to COM2 (terminal 44, 46, 48, or 50) on the 34...51 row (C).
7. If continuing input wiring power for inputs 0...15 to the next terminal base, connect a jumper from terminal 41 (+V1) on this terminal base unit to the power terminal on the next terminal base unit.
8. If continuing input wiring for inputs 0...15 common to the next terminal base, connect a jumper from terminal 42 (COM1) on this terminal base unit to the common terminal on the next terminal base unit.
9. If continuing input wiring power for inputs 16...31 to the next terminal base, connect a jumper from terminal 49 (+V2) on this terminal base unit to the power terminal on the next terminal base unit.
10. If continuing input wiring 16...31 common to the next terminal base, connect a jumper from terminal 50 (COM2) on this terminal base unit to the common terminal on the next terminal base unit.

Connect Wiring for the 1794-OV32 Module

Mount the 1794-OV32 module on a 1794-TB32 or 1794-TB32S terminal base.

1. Connect individual output wiring (0...15) to numbered terminals on the 0...15 row (A) as indicated in [Table 1](#).
2. Connect the associated power to the +V1 terminal (35, 37, 39, or 41) on the 34...51 row (C) as indicated in [Table 1](#).
3. Connect the associated output common (-V1) for outputs 0...15 to COM1 (terminal 36, 38, 40, or 42) on the 34...51 row (C).
4. Connect individual output wiring (16...31) to numbered terminals on the 16...33 row (B) as indicated in [Table 1](#).
5. Connect the associated power to the +V2 terminal (43, 45, 47, or 49) on the 34...51 row (C) as indicated in [Table 1](#).
6. Connect the associated output common (-V2) for outputs 16...31 to COM2 (terminals 44, 46, 48, or 50) on the 34...51 row (C).
7. If continuing power to the next terminal base, connect a jumper from terminal 35, 37, 39, or 41 (+V1) and 43, 45, 47, or 49 (+V2) on this base unit to the power terminal on the next base unit.
8. If continuing output common return to the next base unit, connect a jumper from terminal 36, 38, 40, or 42 (COM1) and 44, 46, 48, or 50 (COM2) on this base unit to common on the next base unit. See the installation instructions for the terminal base unit.

Table 1 - Wiring Connections for 1794-IV32 and 1794-OV32

Channel	Signal	Channel	Signal
0	A-0	16	B-17
1	A-1	17	B-18
2	A-2	18	B-19
3	A-3	19	B-20
4	A-4	20	B-21
5	A-5	21	B-22
6	A-6	22	B-23
7	A-7	23	B-24
8	A-8	24	B-25
9	A-9	25	B-26
10	A-10	26	B-27
11	A-11	27	B-28
12	A-12	28	B-29
13	A-13	29	B-30
14	A-14	30	B-31
15	A-15	31	B-32
+V1 DC power (inputs 0...15)	Power terminals 35, 37, 39, and 41 for inputs 0...15 +V1 connected to terminals 35, 37, 39, and 41		
COM1 DC Return (inputs 0...15)	Common terminals 36, 38, 40, and 42 for inputs 0...15 V1 Return connected to terminals 36, 38, 40, and 42		
+V2 DC power ⁽¹⁾ (inputs 16...31)	Power terminals 43, 45, 47, and 49 for inputs 16...31 +V2 connected to terminals 43, 45, 47, and 49		
COM2 DC return (inputs 16...31)	Common terminals 44, 46, 48, and 50 for inputs 16...31 V2 Return connected to terminals 44, 46, 48, and 50		

(1) 2-wire input devices use signal and return terminals.
3-wire devices use signal, return, and supply terminals.

Figure 1 - 1794-TB32 and 1794-TB32S Terminal Base Wiring for 1794-IV32 and 1794-OV32

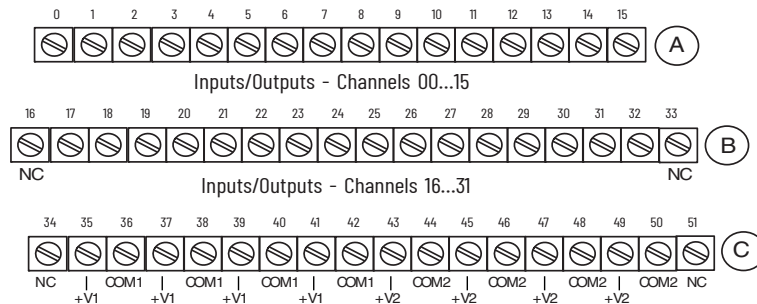

(1794-TB32 shown)

For 1794-OV32, also use the following as signal supply terminals:

+V1 = Terminals 35, 37, 39, and 41

+V2 = Terminals 43, 45, 47, and 49

For 1794-IV32, also use the following as signal return terminals:

COM1 = Terminals 36, 38, 40, and 42

COM2 = Terminals 44, 46, 48, and 50

For 1794-OV32 and 1794-IV32:

NC = No connections (terminals 16, 33, 34, and 51)

Figure 2 - 2-wire and 3-wire Input Wiring for 1794-IV32 and 1794-OV32

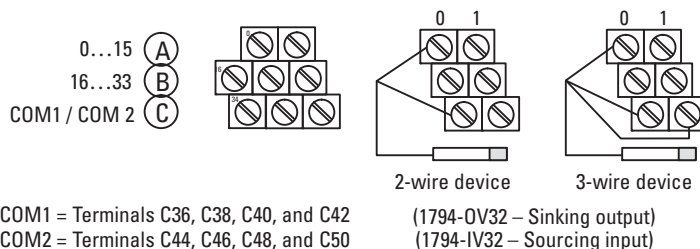

Configure Your Input Module

Configure your input module by setting bits in the configuration word (Word 3).

Table 2 - Image Table Memory Map for the 1794-IV32 Module

Dec.	15	14	13	12	11	10	9	8	7	6	5	4	3	2	1	0
Oct.	17	16	15	14	13	12	11	10	7	6	5	4	3	2	1	0
Read 1	I15	I14	I13	I12	I11	I10	I9	I8	I7	I6	I5	I4	I3	I2	I1	I0
Read 2	I31	I30	I29	I28	I27	I26	I25	I24	I23	I22	I21	I20	I19	I18	I17	I16
Write 1	Not used					Input Filter FT 00...31			Not used							
Where:	I = Input FT = Input filter time															

C, CR, and CF are not available when used with any series 1794-ASB or 1794-ASB2 remote I/O adapters.

Set the Input Filter Time for the 1794-IV32 Module

To set the input filter time, set the associated bits in the output image (complementary word) for the module.

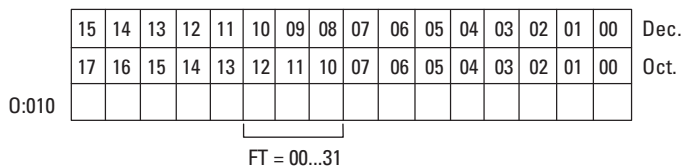

Input Filter Times

Bits			Description	Selected Filter Time
10	09	08	Filter Time for Inputs 00...31	Off-to-On/On-to-Off
0	0	0	Filter time 0 (default)	0.25 ms
0	0	1	Filter time 1	0.5 ms
0	1	0	Filter time 2	1 ms
0	1	1	Filter time 3	2 ms
1	0	1	Filter time 4	4 ms
1	0	1	Filter time 5	8 ms
1	1	0	Filter time 6	16 ms
1	1	1	Filter time 7	32 ms

Configure Your Output Module

Configure your output module by setting bits in the configuration word (Word 3).

Table 3 - Image Table Memory Map for the 1794-OV32 Module

Dec.	15	14	13	12	11	10	9	8	7	6	5	4	3	2	1	0
Oct.	17	16	15	14	13	12	11	10	7	6	5	4	3	2	1	0
Read 0	Not used - Set to 0															
Write 1	O15	O14	O13	O12	O11	O10	O9	O8	O7	O6	O5	O4	O3	O2	O1	O0
Write 2	O31	O30	O29	O28	O27	O26	O25	O24	O23	O22	O21	O20	O19	O18	O17	O16
Where:	O = Output															

Specifications

Specifications - FLEX I/O Digital Sourcing Input Module 1794-IV32

Attribute	Value
Number of inputs	32, current, sourcing
Recommended terminal base unit	1794-TB32, 1794-TB32S, 1794-TB62DS, 1794-TB62EXD4X15
On-state voltage, min	19.2V DC
On-state voltage, nom	24V DC
On-state voltage, max	31.2V DC
On-state current, min	2.0 mA
On-state current, nom	4.1 mA @ 24V DC
On-state current, max	6.0 mA
Off-state voltage, max	5V DC
Off-state current, max	1.5 mA
Input impedance	6 k Ω
Isolation voltage	50V (continuous), Basic Insulation Type Type tested @ 850V DC for 60 s, between field side and system No isolation between individual channels
Input filter time ⁽¹⁾ Off-to-On On-to-Off	See Input Filter Times table
Flexbus current	40 mA @ 5V DC
Power dissipation, max	6 W @ 31.2V DC
Thermal dissipation, max	20.5 BTU/hr @ 31.2V DC

(1) Input Off-to-On filter time is the time from a valid input signal to recognition by the module.
Input On-to-Off filter time is the time from the input signal dropping below the valid level to recognition by the module.

Specifications - FLEX I/O Digital Sinking Output Module 1794-OV32

Attribute	Value
Number of outputs	32, current, sinking
Recommended terminal base unit	1794-TB3, 1794-TB3S, 1794-TB3K, 1794-TB3SK
Output voltage, min	10V DC
Output voltage, nom	24V DC
Output voltage, max	31.2V DC
Output current rating	14 A max per module 6 A total for channels 0...15 8 A total for channels 16...31
On-state current	1.0 mA min per channel 500 mA max per channel
Surge current	2 A for 50 ms each, repeatable every 2 seconds
Off-state leakage, max	0.5 mA
Isolation voltage	50V (continuous), Basic Insulation Type Type tested at 707V DC for 60 s, between field side and system No isolation between individual channels
Output signal delay ⁽¹⁾ Off-to-On On-to-Off	0.5 ms 1.0 ms
Flexbus current	110 mA @ 5V DC
Power dissipation, max	4.4 W @ 31.2V DC
Thermal dissipation, max	8.53 BTU/hr @ 31.2V DC

(1) Delay time is the time from the receipt of an output On or Off command to the output actually turning On or Off.

General Specifications

Attribute	1794-IV32	1794-OV32
Terminal base screw torque	Determined by the installed terminal base	
Dimensions, approx. (H x W x D)	94 x 94 x 69 mm (3.7 x 3.7 x 2.7 in.)	
Indicators (field side)	32 yellow status indicators	
External DC power supply voltage, nom	24V DC	
External DC power voltage range	19.2...31.2V DC (includes 5% AC ripple)	10...31.2V DC (includes 5% AC ripple)
North American temp code	T4	
Keyswitch position	2	
Enclosure type rating	None (open-style)	
Weight, approx.	77 g (2.72 oz)	80 g (2.82 oz)
Wire size	Determined by the installed terminal base	
Wiring category ⁽¹⁾	2 – on signal ports	

(1) Use this Conductor Category information for planning conductor routing as described in the appropriate System Level Installation Manual. Also see the Industrial Automation Wiring and Grounding Guidelines, publication [1770-4.1](#), for more information.

Environmental Specifications

Attribute	Value
Operating temperature	IEC 60068-2-1 (Test Ad, operating cold), IEC 60068-2-2 (Test Bd, operating dry heat), IEC 60068-2-14 (Test Nb, operating thermal shock): 0...55 °C (32...131 °F)
Storage temperature	IEC 60068-2-1 (Test Ab, unpackaged nonoperating cold), IEC 60068-2-2 (Test Bb, unpackaged nonoperating dry heat), IEC 60068-2-14 (Test Na, unpackaged nonoperating thermal shock): -40...+85 °C (-40...+185 °F)
Temperature, surrounding air, max	55 °C (131 °F)
Relative humidity	IEC 60068-2-30 (Test Db, unpackaged damp heat): 5...95% noncondensing
Vibration	IEC60068-2-6 (Test Fc, operating): 5 g @ 10...500 Hz
Shock, operating	IEC60068-2-27 (Test Ea, unpackaged shock): 30 g
Shock, nonoperating	IEC60068-2-27 (Test Ea, unpackaged shock): 50 g
Emissions	IEC 61000-6-4
ESD immunity	IEC 61000-4-2: 6 kV contact discharges 8 kV air discharges
Radiated RF immunity	IEC 61000-4-3: 10V/m with 1 kHz sine-wave 80% AM from 80...2000 MHz 10V/m with 200 Hz 50% Pulse 100% AM @ 900 MHz 10V/m with 200 Hz 50% Pulse 100% AM @ 1890 MHz 1V/m with 1 kHz sine-wave 80% AM from 2000...2700 MHz
EFT/B immunity	IEC 61000-4-4: ±2 kV @ 5 kHz on power ports ±2 kV @ 5 kHz on signal ports
Surge transient immunity	IEC 61000-4-5: ±1 kV line-line(DM) and ±2 kV line-earth(CM) on signal ports
Conducted RF immunity	IEC 61000-4-6: 10V rms with 1 kHz sine-wave 80% AM from 150 kHz...80 MHz

Certifications

Certifications (when product is marked) ⁽¹⁾	Value
c-UL-us	UL Listed Industrial Control Equipment, certified for US and Canada. See UL File E322657. UL Listed for Class I Division 2 Group A,B,C,D Hazardous Locations, certified for U.S. and Canada. See UL File E334470.
UK and CE	UK Statutory Instrument 2016 No. 1091 and European Union 2014/30/EU EMC Directive, compliant with: EN 61326-1; Meas./Control/Lab., Industrial Requirements EN 61000-6-2; Industrial Immunity EN 61131-2; Programmable Controllers (Clause 8, Zone A & B) EN 61000-6-4; Industrial Emissions UK Statutory Instrument 2012 No. 3032 and European Union 2011/65/EU RoHS, compliant with: EN 63000; Technical documentation
KC	Korean Registration of Broadcasting and Communications Equipment, compliant with: Article 58-2 of Radio Waves Act, Clause 3
RCM	Australian Radiocommunications Act, compliant with: EN 61000-6-4; Industrial Emissions

(1) See the Product Certification link at rok.auto/certifications for Declaration of Conformity, Certificates, and other certification details.

Additional Resources

For more information on the products that are described in this publication, use these resources. You can view or download publications at rok.auto/literature.

Resources	Description
FLEX I/O and FLEX I/O-XT Selection Guide, publication 1794-S6002	Provides information on how to select FLEX I/O and FLEX I/O-XT™ adapters, terminal bases, I/O modules, and accessories.
Industrial Automation Wiring and Grounding Guidelines, publication 1770-4.1	Provides general guidelines for installing a Rockwell Automation industrial system.
Product Certifications website, rok.auto/certifications	Provides declarations of conformity, certificates, and other certification details.

Notes:

Rockwell Automation Support

Use these resources to access support information.

Technical Support Center	Find help with how-to videos, FAQs, chat, user forums, Knowledgebase, and product notification updates.	rok.auto/support
Local Technical Support Phone Numbers	Locate the telephone number for your country.	rok.auto/phonesupport
Technical Documentation Center	Quickly access and download technical specifications, installation instructions, and user manuals.	rok.auto/techdocs
Literature Library	Find installation instructions, manuals, brochures, and technical data publications.	rok.auto/literature
Product Compatibility and Download Center (PCDC)	Download firmware, associated files (such as AOP, EDS, and DTM), and access product release notes.	rok.auto/pcdc

Documentation Feedback

Your comments help us serve your documentation needs better. If you have any suggestions on how to improve our content, complete the form at rok.auto/docfeedback.





Waste Electrical and Electronic Equipment (WEEE)



At the end of life, this equipment should be collected separately from any unsorted municipal waste.

Rockwell Automation maintains current product environmental compliance information on its website at rok.auto/pec.

Rockwell Otomasyon Ticaret A.Ş. Kar Plaza İş Merkezi E Blok Kat:6 34752 İçerenköy, İstanbul, Tel: +90 (216) 5698400 EEE Yönetmeliğine Uygundur

Connect with us.    

rockwellautomation.com — expanding **human possibility**[®]

AMERICAS: Rockwell Automation, 1201 South Second Street, Milwaukee, WI 53204-2496 USA, Tel: (1) 414.382.2000

EUROPE/MIDDLE EAST/AFRICA: Rockwell Automation NV, Pegasus Park, De Kleetlaan 12a, 1831 Diegem, Belgium, Tel: (32) 2663 0600

ASIA PACIFIC: Rockwell Automation SEA Pte Ltd, 2 Corporation Road, #04-05, Main Lobby, Corporation Place, Singapore 618494, Tel: (65) 6510 6608

UNITED KINGDOM: Rockwell Automation Ltd., Pitfield, Kiln Farm, Milton Keynes, MK11 3DR, United Kingdom, Tel: (44)(1908) 838-800

Allen-Bradley, expanding human possibility, FLEX I/O, FLEX I/O-XT, Rockwell Automation, and TechConnect are trademarks of Rockwell Automation, Inc. Trademarks not belonging to Rockwell Automation are property of their respective companies.

Publication 1794-IN122D-EN-P - June 2024 | Supersedes Publication 1794-IN122C-EN-P - July 2018
Copyright © 2024 Rockwell Automation, Inc. All rights reserved.