

3300 XL 50 mm Proximity Transducer System

Datasheet

Cordant™

174014 Rev. L

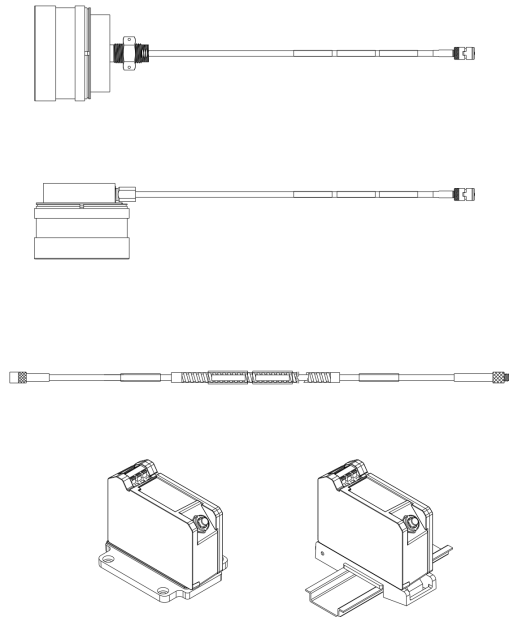

Description

The 3300 XL 50 mm Transducer System consists of a separate 50 mm probe, an extension cable, and a 3300 XL 50 mm Proximitor Sensor. The large diameter coil gives this system a maximum linear range of 27.9 mm (1100 mils), the longest linear range of our eddy current transducer line. This linear range makes the 3300 XL 50 mm Transducer System ideal for measuring the differential expansion (DE) or rotor expansion (RX) of large steam turbine generators that results from the difference in growth rates between the turbine rotor and the machine stator (casing).

Measuring Differential Expansion

The Differential Expansion measurement is made by using two proximity transducers that observe a collar or ramp some distance from the thrust bearing. Typical transducer mounting arrangements that require the 3300 XL 50 mm Transducer's long linear range include:

- Two transducers observing the same side of a collar.
- Two complementary input transducers observing opposite sides of a collar, effectively doubling the measurable DE range.

The criteria for selecting a mounting method are the size of the available target, the expected amount of rotor axial movement, and the type of DE target that exists in the machine. If the collar height is sufficient and the required total measurement range is less than 27.9 mm 1.1 inches, the preferred configuration for redundant measurements is to use two transducers observing the same side of a collar. When 28 mm to 56 mm (1.1 to 2.2 inches) of total range are required, install the transducers in a complementary fashion



Baker Hughes 

on opposite sides of the differential expansion collar or other target material.

System Compatibility

The 3300 XL 50 mm probe comes in three case & thread configurations to physically replace all standard 7200 50 mm systems (including side and rear exit probes). The standard 7200 style mounting brackets are still available as accessories. In addition, a new bracket to adapt the probe to the 50 mm DE Integral transducer sliding mount base is also available. The Proximitor Sensor has a 0.394 V/mm (10 mV/mil) output that is identical to that of the 7200 and 50 mm DE Integral systems, which allows customers to upgrade without requiring any changes in the monitor configuration. When upgrading from previous systems, every transducer system component (probe, extension cable, and Proximitor Sensor) must be replaced with 3300 XL 50 mm components.

Proximity Probe and Extension Cable

The 3300 XL 50 mm probe is designed to survive the harshest steam turbine DE environments. It can continually operate and maintain its accuracy in high temperatures up to 200°C (392°F), and can withstand intermittent high temperatures up to 250°C (482°F). The 50 mm probe has both a front and rear seal which, combined with the High Temperature FluidLoc cable (standard on all 50 mm probes), prevent moisture from entering the probe tip. Special high-temperature ClickLoc connectors are also standard on the probe and extension cable. Each probe and cable comes with connector protectors and a disposable connector protector installation tool to ensure that the connectors remain free of contamination. The ClickLoc connector on the probe lead features a removable collar that facilitates routing the cable through tight clearances.

The 3300 XL 50 mm probe is available in straight exit case styles with ½–20 English threads or M14x1.5 metric threads, including a locknut with predrilled safety wire holes. The side exit probe has two ¼–20 mounting holes in

the rear of the probe case. For both straight exit and side exit probes the overall case diameter is 1.99 inches.

Proximitor Sensor

The 3300 XL 50 mm Proximitor Sensor has the same advanced features as all 3300 XL Proximitor Sensors. Its thin design allows it to be mounted in either a high-density DIN-rail installation or a more traditional panel mount configuration. Improved RFI/EMI immunity allows the 3300 XL Proximitor Sensor to achieve European CE mark approvals without any special mounting considerations. This RFI immunity prevents the transducer system from being adversely affected by nearby high frequency radio signals. SpringLoc terminal strips on the Proximitor Sensor require no special installation tools and facilitate faster, highly robust field wiring connections.



Proximitor Sensors are supplied by default from the factory calibrated to AISI 4140 steel. Calibration to other target materials is available upon request.

Mounting Accessories

The correct operation of the transducer system must be initially verified during installation and periodically thereafter. This is done by physically moving the transducer to simulate the motion of the shaft collar. This requires a mounting bracket that allows the transducer system to slide relative to the shaft rotor and collar.

An optional Sliding Bracket can be ordered for the 50 mm Transducer for both single transducer and complementary input applications. This mounting bracket allows you to verify the transducer system and gap the probes by sliding the transducer system through its linear range. The base plate of the sliding bracket is installed on the inner surface of the turbine case near the differential expansion collar. Probes are installed in the probe clamp that attaches to the sliding

carriage. The sliding carriage slides onto and is secured to the base plate with bolts and safety wire. To verify and install the transducer, loosen the bolts securing the sliding carriage to the base plate and move the sliding carriage and probes. A verification kit with spindle micrometer can be temporarily secured to the base plate to provide a reference for axial verification measurements. The spindle micrometer measures the movement of the transducer system relative to the collar during these verification tests.

Specifications

Unless otherwise noted, the following specifications are for a 3300 XL 50 mm Proximitor Sensor, extension cable and probe between 0°C and +45°C (+32°F to +113°F) at a maximum altitude of 2000 meters, with a -24 Vdc power supply, a 10 kΩ load, a Bently Nevada supplied AISI 4140 steel target that is 102 mm (4.0 in) diameter or larger. The system accuracy and interchangeability specifications do not apply when using a transducer system calibrated to any target other than a Bently Nevada AISI 4140 steel target.

Electrical

Proximitor Sensor Input	Accepts one non-contacting 3300 XL 50 mm Proximity Probe and Extension Cable.
Power	Requires -17.5 Vdc to -26 Vdc without barriers at 12 mA maximum consumption, -23 Vdc to -26 Vdc with barriers. Operation at a more positive voltage than -23.5 Vdc can result in reduced linear range.
Output resistance	50 Ω
Extension cable capacitance	69.9 pF/m (21.3 pF/ft) typical

Field wiring	0.2 to 1.5 mm ² (16 to 24 AWG) Recommend using three-conductor shielded triad cable.
Linear Range	27.9 mm (1100 mils). Linear range begins at approximately 1.3 mm (50 mils) from target and is from 1.3 to 29.2 mm (50 to 1150 mils) (approximately -1.5 to -12.5 Vdc).
Average Scale Factor (ASF)	394 mV/mm (10 mV/mil) nominal
Deviation from best fit straight line (DSL)	Less than ±0.74 mm (±29 mils)
System performance over extended temperatures	Over a probe temperature range of -35°C to +120°C (-31°F to +248°F) with the Proximitor Sensor and extension cable between 0°C to +45°C (+32°F to +113°F), the DSL remains within ±2.03 mm (±80 mils). Over a Proximitor Sensor and extension cable temperature range of -35°C to +65°C (-31°F to +149°F) with the probe between 0°C to +45°C (+32°F to +113°F), the DSL remains within ±2.03 mm (±80 mils).
Recommended Minimum Target Size	102 mm (4.0 in) diameter (flat target)

Probe DC Resistance	Resistance from Center to Coaxial Conductor	
	Probe Length	
	1.0 m	6.4 ± 0.5 Ω
	5.0 m	7.6 ± 0.8 Ω
	9.0 m	8.9 ± 1.1 Ω
Cable DC Resistance	Resistance from Center to Coaxial Conductor	
	Cable Length	Resistance from Coaxial to Coaxial Conductor
	4.0 m	1.0 ± 0.25 Ω
	8.0 m	2.0 ± 0.5 Ω
		0.3 ± 0.1 Ω
		0.6 ± 0.2 Ω
Electrical Classification	Complies with the European CE mark.	

Mechanical

Probe Tip Material	Polyphenylene Sulfide (PPS).
Probe Case Material	AISI 304 stainless steel (SST).
Probe Cable Specifications	75 Ω triaxial, perfluoroalkoxyethylene (PFA) insulated FluidLoc probe cable in the following total probe lengths: 1, 5 or 9 meters.
Extension Cable Material	75 Ω triaxial, perfluoroalkoxyethylene (PFA) insulated FluidLoccable.
Proximator Sensor Material	A380 aluminum
Sliding Bracket Material	Anodized aluminum and stainless steel
System Length	5 or 9 meters including extension cable

Probe and Extension Cable Armor (optional)	Flexible SST with PFA outer jacket.
Tensile Strength (maximum rated)	330 N (75 pounds) probe case to probe lead. 270 N (60 pounds) at probe lead to extension cable connectors.
Connector material	Gold-plated brass and gold-plated beryllium copper

Torque Specifications

Description	Maximum Rated
All threaded probe cases	45 N•m (400 in•lbf)
M5x.8 sliding bracket cap screws	9.6 N•m (85 in•lbf)

Connector-to-connector Torque

Recommended torque	Finger tight
Maximum torque	0.565 N•m (5 in•lb)
Minimum Bend Radius (with or without SST Armor)	25.4 mm (1.0 in)

Thread Engagement Limits

Probe Case Thread	Maximum Length of Thread Engagement
1/2-20	0.750 in
M14x1.5	21 mm



Maximum thread engagement lengths are per the industry standard of 1.5 times the nominal thread diameter. A fit class matching that of the external probe thread is assumed for all internal threads. Applications with thread engagement lengths exceeding the values in the table above may exhibit binding during installation. Contact your Bently Nevada representative if you require probe thread engagement lengths exceeding the values above. Bently Nevada does not replace proximity probes under warranty due to excessive thread engagement lengths.

Relative Humidity

Less than a 3% change in Average Scale Factor (ASF) when tested in accordance with IEC standard 68-2-66.

3300 XL probes are designed to seal differential pressure between the probe tip and case. The probe is sealed with Viton O-rings. Probes are not pressure tested prior to shipment. Contact our custom design department if you require a test of the pressure seal for your application.



It is the responsibility of the customer or user to ensure that all liquids and gases are contained and safely controlled should leakage occur from a proximity probe. In addition, solutions with high or low pH values may erode the tip assembly of the probe causing media leakage into surrounding areas. Bently Nevada does not be held responsible for any damages resulting from leaking 3300 XL proximity probes. In addition, 3300 XL proximity probes does not be replaced under the service plan due to probe leakage.

Environmental Limits

Probe Temperature Range

Operating and Storage Temperature	-35°C to +200°C (-31°F to +392°F)
-----------------------------------	-----------------------------------

Short-term Operating and Storage Temperature	+250°C (+482°F) for less than 24 hours.
--	---

Extension Cable Temperature Range

Operating and Storage Temperature	--51°C to +200°C (-31°F to +392°F)
-----------------------------------	------------------------------------

Proximitior Sensor Temperature Range

Operating Temperature	-51°C to +100°C (-60°F to +212°F)
-----------------------	-----------------------------------

Storage Temperature	-51°C to +105°C (-60°F to +221°F)
---------------------	-----------------------------------

Sliding Bracket Temperature Range

Operating and Storage Temperature	-35°C to +200°C (-31°F to +392°F)
-----------------------------------	-----------------------------------

Compliance and Certifications

FCC

This device complies with part 15 of the FCC Rules. Operation is subject to the following two conditions:

- This device may not cause harmful interference.
- This device must accept any interference received, including interference that may cause undesired operation.

EMC

European Community Directive:

EMC Directive 2014/30/EU

Standards

EN 61000-6-2; Immunity for Industrial Environments

EN 61000-6-4; Emissions for Industrial Environments

RoHS

European Community Directive:

RoHS Directive 2011/65/EU

China RoHS

Cables associated with the product(s) mentioned in this datasheet have an EFUP designation of 15 years, in accordance with SJ/T 11364-2024.



Maritime

2019 Rules for Conditions of Classification,
Part 1, 1-1-1/7.7, 1-1-A3, 1-1-A4

2019 Rules for Conditions of Classification,
Part 1, Offshore Units and Structures
1-1-4/9.7, 1-1-A2, 1-1-A3

Hazardous Area Approvals



For the detailed listing of country and product-specific approvals, refer to the [Approvals Quick Reference Guide \(108M1756\)](#).

For additional technical documentation, please log in to bntechsupport.com and access the Bently Nevada Media Library.

cNRTLus

3300 XL Proximity Sensor

<p>ia</p> <p>When installed with intrinsically safe zener barriers per drawing 141092 or when installed with galvanic isolators.</p>	<p>Class I, Zone 0: AEx/Ex ia IIC T4/T5 Gc; Class I, Groups A, B, C, and D, Class II, Groups E, F and G, Class III;</p> <p>T5 @ Ta= -55°C to + 40°C. T4 @ Ta= -55°C to + 80°C.</p>
<p>nA, ec</p> <p>When installed with non-incendive circuit connected per drawing 140979.</p>	<p>Class I, Zone 2: AEx/Ex nA IIC T4/T5 Gc; Class I, Division 2, Groups A, B, C, and D; Class I, Zone 2: AEx/Ex ec IIC T4/T5 Gc; Class I, Division 2, Groups A, B, C, and D;</p> <p>T5 @ Ta= -55°C to + 40°C T4 @ Ta= -55°C to + 80°C</p>

3300 XL Probe

<p>ia</p> <p>When installed with intrinsically safe zener barriers per drawing 141092 or when installed with galvanic isolators.</p>	<p>Class I, Zone 0: AEx/Ex ia IIC T5...T1 Gc; Class I, Groups A, B, C, and D, Class II, Groups E, F, and G, Class III;</p> <p>(see Temperature Schedule table to follow)</p>
---	--

<p>nA, ec</p> <p>When installed with non-incendive circuit connected per drawing 140979.</p>	<p>Class I, Zone 2: AEx/Ex nA IIC T5...T1 Gc; Class I, Division 2, Groups A, B, C, D; Class I, Zone 2: AEx/Ex ec IIC T5...T1 Gc; Class I, Division 2, Groups A, B, C, and D;</p> <p>(see Temperature Schedule table to follow)</p>
---	---

ATEX/IECEx



3300 XL Proximity Sensor

<p>ia</p>	<p style="text-align: center;"></p> <p>II 1 G Ex ia IIC T4/T5 Ga Ex ia III C T90C/T105C Dc For EPL Dc: T105C @ Ta = -55°C to 100°C T90C @ Ta = -55°C to +85°C</p> <table border="1" data-bbox="1117 835 1477 1083"> <tr> <td>Ui= -28V</td> <td>Uo= -28V</td> </tr> <tr> <td>Ii= 140mA</td> <td>Io= 140mA</td> </tr> <tr> <td>Pi= 0.91W</td> <td>Po= 0.742W</td> </tr> <tr> <td>Ci= 47nF</td> <td>Co= 1.5nF</td> </tr> <tr> <td>Li= 1460µH</td> <td>Lo= 610µH</td> </tr> </table>	Ui= -28V	Uo= -28V	Ii= 140mA	Io= 140mA	Pi= 0.91W	Po= 0.742W	Ci= 47nF	Co= 1.5nF	Li= 1460µH	Lo= 610µH
Ui= -28V	Uo= -28V										
Ii= 140mA	Io= 140mA										
Pi= 0.91W	Po= 0.742W										
Ci= 47nF	Co= 1.5nF										
Li= 1460µH	Lo= 610µH										
<p>nA,ec</p>	<p style="text-align: center;"></p> <p>II 3 G Ex nA IIC T4/T5 Gc Ex ec IIC T4/T5 Gc</p> <table border="1" data-bbox="1117 1249 1477 1295"> <tr> <td>Ui= -28V</td> <td>Ii= 140 mA</td> </tr> </table> <p>T5 @ Ta= -55°C to + 40°C T4 @ Ta= -55°C to + 80°C</p>	Ui= -28V	Ii= 140 mA								
Ui= -28V	Ii= 140 mA										

3300 XL Probe



Probe entity parameters are met when used with BN extension cables and connected to BN Prox.

<p>ia</p>	<p style="text-align: center;"></p> <p>II 1 G Ex ia IIC T5...T1 Ga, (see Temperature Schedule table to follow)</p> <p>Ex ia IIIC T90°C ... T280°C Dc For EPL Dc:</p> <table border="1" data-bbox="386 428 743 579"> <tr> <td>Ui = -28V</td> <td>Ci = 1.5 nF</td> </tr> <tr> <td>li = 140 mA</td> <td>Li = 610 μH</td> </tr> <tr> <td>Pi = 0.91 W</td> <td></td> </tr> </table>	Ui = -28V	Ci = 1.5 nF	li = 140 mA	Li = 610 μH	Pi = 0.91 W	
Ui = -28V	Ci = 1.5 nF						
li = 140 mA	Li = 610 μH						
Pi = 0.91 W							
<p>nA,ec</p>	<p style="text-align: center;"></p> <p>II 3 G Ex nA IIC T5...T1 Gc, Ex ec IIC T5...T1 Gc, (see Temperature Schedule table to follow)</p> <table border="1" data-bbox="386 793 743 846"> <tr> <td>Ui = -28V</td> <td>li = 140 mA</td> </tr> </table>	Ui = -28V	li = 140 mA				
Ui = -28V	li = 140 mA						

Hazardous Area Conditions of Safe Use

cNRTLus:

ia

Install per Bently Nevada drawing 141092.

nA, ec

Install per Bently Nevada drawing 140979.

ATEX/IECEx:

ia

Install per Bently Nevada drawing 141092.

nA, ec

The Proximitor must be installed so as to provide the terminals with a degree of protection of at least IP54.

Temperature Schedule

Temperature Classification	Ambient Temperature (Probe Only)
For EPL Ga and Gc	
T1	-55°C to +232°C
T2	-55°C to +177°C
T3	-55°C to +120°C
T4	-55°C to +80°C
T5	-55°C to +40°C
For EPL Dc	
T280°C @ Ta	-55°C to +232°C
T225°C @ Ta	-55°C to +177°C
T170°C @ Ta	-55°C to +120°C
T130°C @ Ta	-55°C to +80°C
T105°C @ Ta	-55°C to +100°C
T90°C @ Ta	-55°C to +40°C