

Section 3

System Overview

Purpose

To provide an overview of the Trusted system and its components.

Objectives

- To understand the system architecture.
- To understand the types and names of modules used the Trusted system.
- To understand the configuration limits of the systems.

System Overview

The Trusted programmable controller is comprised of three main assemblies; the controller assembly, expander assembly, and power supply assembly. Within the controller and expander assemblies are various triplicated modules.

All assemblies consist of a 19 inch chassis in which the modules are installed. Mounting brackets allow the chassis to be either front (rack) or rear (panel) mounted.

The Trusted system communicates with external systems through either the main processor, dedicated communication modules or a gateway (PC) module. Multiple serial and Ethernet communications using a variety of protocols are possible. Communication modules may be installed in both the controller and expander chassis.

Names of Trusted Components

Controller Assembly

- Controller Chassis
- Processor Modules
- Communication Modules
- Gateway Module
- Expander Interface
- I/O Modules

A controller chassis can house a main processor, its standby, and up to 8 other modules (I/O, communication, gateway, and/or expander).

Expander Assembly

- Expander Processor
- I/O Modules
- Communication Modules

An expander chassis can house an expander processor, its standby, and up to 12 other modules (I/O, communication).

Power System

- Power Shelf
- Power Packs

Power packs can provide field power as well as system power.

Miscellaneous Components

- Field Termination Assemblies
- Cables (Communication, Expander, I/O)

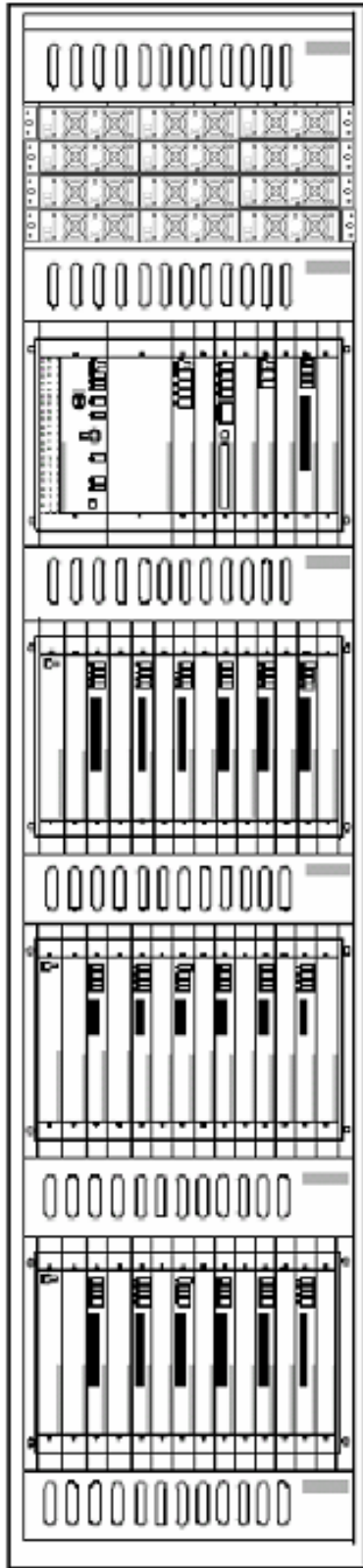

Fan Tray

Power System
(4 Power Shelves + 12 Power Packs)

Fan Tray

Controller Assembly
(Chassis + TMR Processor + Interfaces + I/O)

Fan Tray

Expander Assembly
(Chassis + Expander Processor + I/O)

Fan Tray

Expander Assembly

Fan Tray

Expander Assembly

Grill

Figure 3-1: Trusted System

System Operation

The Trusted system operates as follows:

Process state data (switch position, transmitter reading, etc.) is sensed by an input module. Process state data is buffered on each input module and transmitted over the triple redundant inter-module bus (IMB).

The TMR processors read and vote the process state information. The processors perform application programs that have been stored in memory. The processors operate as a triplicated set, sharing information with each other and running in tight synchronization. The TMR processors calculate output commands to be sent to outputs.

Tripllicated output commands are sent back over the IMB to the appropriate output module(s). The output module(s) receive the commands and vote the data. Output circuits are driven by the majority-voted commands.

The Trusted system continuously repeats this scan sequence at very high speed providing continuous, fault-tolerant control. If an internal circuit within the system fails, it is out-voted, the failure is annunciated, and the process continues operating without interruption.

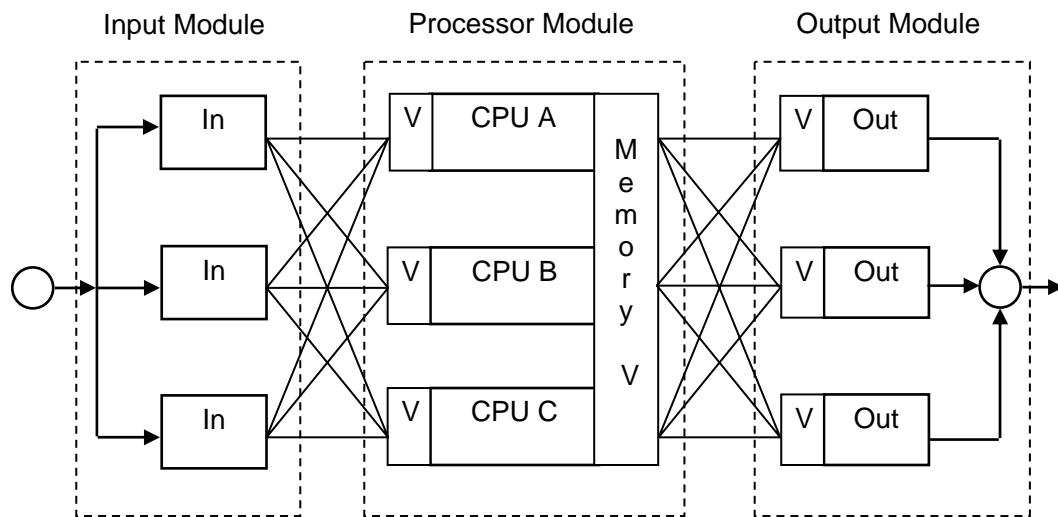

Figure 3-2: Trusted System Architecture and Operation

Trusted is a fault tolerant system designed to be 'fail-operational/fail-safe'. When a single failure occurs, the system continues to operate. This is considered a fail-operational state. The system will continue to operate in this state until the failed module is replaced and the system is returned to a fully operational state. If second failure occurs in a parallel circuit before the first failed module is replaced, the second failure will cause the system to shut down. This is considered a fail-safe state. This fail-operational/fail-safe design is also called 3-2-0 operation, as shown in Figure 3-3.

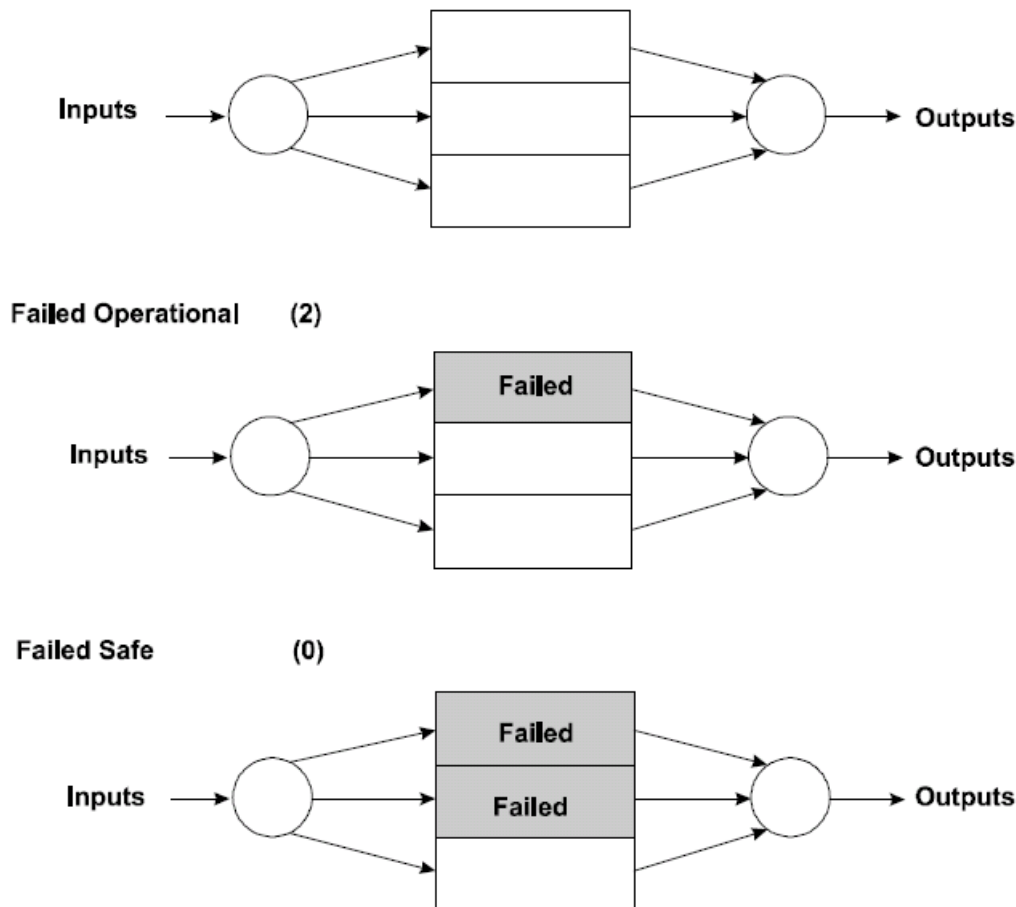

Figure 3-3: 3-2-0 Operation

If a standby module is installed, the primary (active) module will swap operation with the standby as soon as there is a *single* failure. The original active module will not wait for two failures before swapping. This is considered 3-3-2-0 operation.

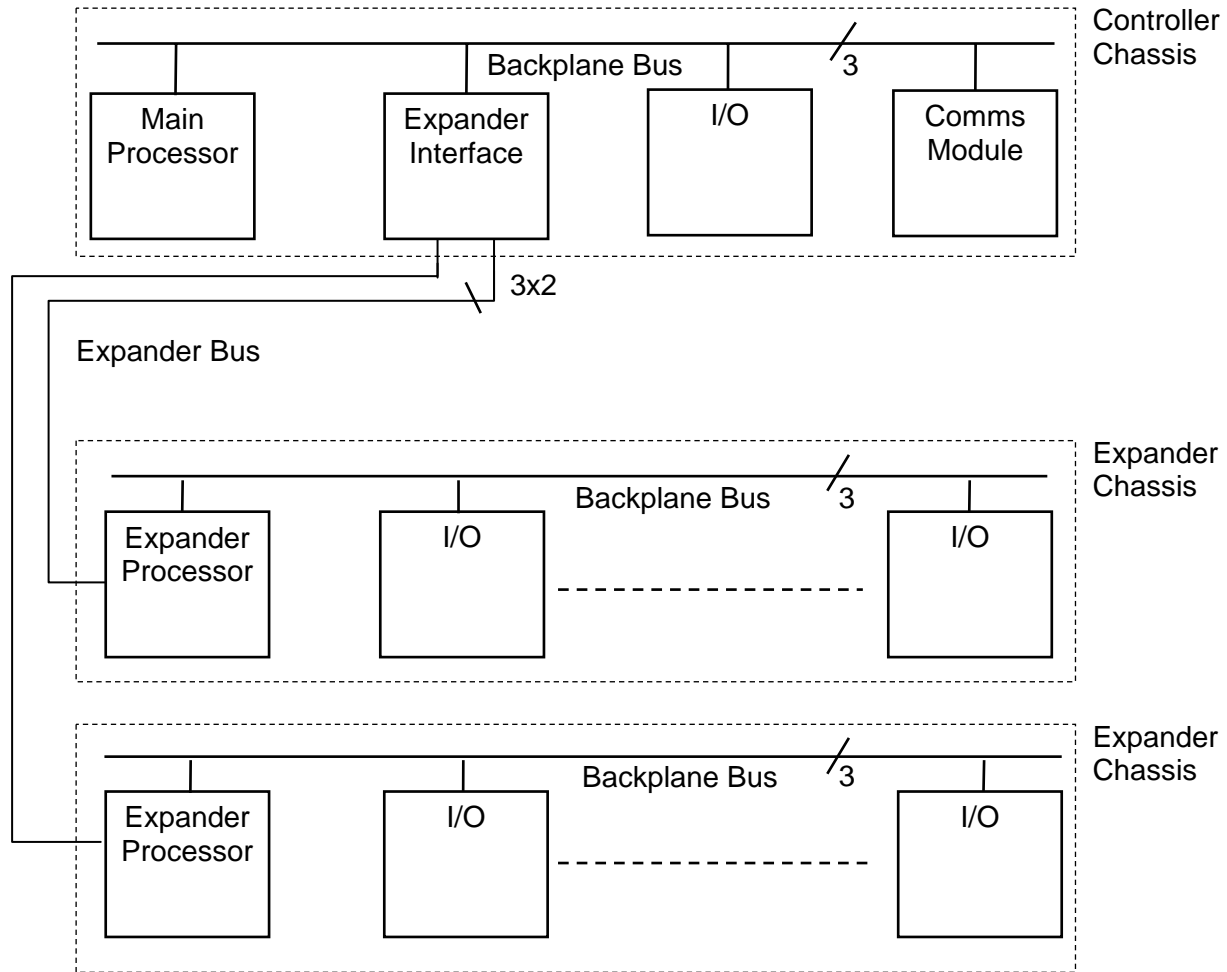

Figure 3-4: Trusted System Block Diagram

Configuration Limits

Like any programmable controller, the Trusted system has various physical and environmental constraints.

I/O System

Different I/O modules have different point densities (with 40 being the most common). A controller assembly can contain up to 8 I/O modules. A controller assembly can physically connect to up to 28 expander assemblies (up to 4 pairs of expander interfaces each with up to 7 connections). Expander assemblies can house up to 12 I/O modules. This would equal 336 I/O modules. However, a controller (processor) has a maximum memory allocation for up to 100 I/O module slots. 100 module slots x 40 channels per module (typical) = 4,000 I/O. However, the greater the number of I/O modules, the longer the scan time of the system. (Scan time is roughly

4 msec per I/O module.) Therefore, considering the different I/O module redundancy schemes (i.e., companion slot or smart slot) along with scan time constraints, there is no “typical” limit to the number of field I/O the system can accommodate. A single large system could be broken down into smaller units, each communicating with each other and sharing information using safety certified peer to peer communications.

Expander chassis must be within approximately 100 cable meters of the controller chassis when using wire cable. The distance between chassis may be 10 km when using fiber.

Communications

Internal resource considerations limit the number of communication modules to 4.

Communication Standards

Serial:	RS232/422/485	(4 per module)
Ethernet:	100BaseT	(2 per module)

Communication Protocols

- Modbus (Slave or Master)
- TCP/IP
- OPC

Communication Speed

Varies depending upon standard and protocol

Input Power

110-220 Vac 50/60 Hz

The power system consists of a power shelf (chassis) and power packs (modules). Each power pack can provide up to 750W of power and each shelf can hold up to three power packs. Up to four power shelves can be stacked together providing a total of up to 9,000W of power. The power system provides 24Vdc for the Trusted system or 28Vdc adjustable field power.

This page intentionally left blank.

Section 4

System Build

Purpose

To summarize how to assemble a Trusted system.

Objectives

- To understand the environmental limits of the system.
- To review module heat dissipation and weight.
- To be able to install chassis, power, cables and modules.

Environmental Limits

The design of each installation must ensure that the operating environment is within the tolerances of the equipment. Consideration must be given to proper control of:

- Temperature
- Humidity
- Contaminants
- Vibration and shock
- EMI / RFI

Operating temperature

The operating temperature range within the cabinet must remain within -5° to 60°C (23° to 140°F) with forced cooling. It is recommended that the temperature be kept substantially below the maximum to prolong equipment life. Extreme changes of temperature (greater than plus or minus 0.5°C (1°F) per minute) should be avoided since such fluctuations can generate thermal shock and degrade the quality of electrical connections.

Non-operational temperature

The following non-operational (storage and transit) temperatures must be adhered to.

1. Packed
 - a Temperature ranges must not exceed -40° to 100°C (-40° to 212°F).
 - b Humidity levels must not exceed 5 to 95%, non-condensing.
2. Unpacked
 - a Temperature ranges must not exceed -25° to 70°C (-13° to 158°F).
 - b Humidity levels should be maintained at 5 to 95%, non-condensing.
 - c Equipment must be protected against the ingress of water.

Humidity

The system is designed to operate in the range of 5 to 95% relative humidity, non-condensing. It is important to avoid changes of humidity and temperature that could produce condensation. Condensation on any type of electrical equipment can result in equipment failures or improper operation.

Contaminants

The system includes ventilated housings that allow the free circulation of air for maximum cooling efficiency. Since the electronics are exposed to the ambient air conditions, protection must be provided to guard against exposure to the following:

1. Corrosive chemicals, e.g. high concentrations of H₂S.
2. Particulate contaminants, including dust or conductive materials.
3. Liquids, through direct contact or condensation.

Independent tests have been performed to show that standard modules meet ANSI/ISA S.71.04 G3 and GX ratings. Modules are available with a conformal coating option to increase their robustness in extremely harsh environments.

Shock and vibration

The system is designed to withstand shock and vibration to 1g sinusoidal sweep, 57Hz to 150Hz. Care must be taken to isolate the system from any sources of extreme mechanical shock or vibration.

EMI/RFI

The system has been designed to satisfy the requirements of IEC 801-3. Input transient tolerance to 500V. Tolerance to radiated fields of 10V/m, 27MHz to 500MHz.

Grounding

Grounding is important for providing a path for electrostatic discharge and for safe conduction of current should a short occur within the system or its wiring. For these reasons it is particularly important that the safety ground wires be attached on the input power terminals and properly connected to ground. Grounding can be divided into two categories: Safety grounding and EMI grounding.

Safety grounding

Safety grounding is provided through the primary power connection. The ground terminals on each input power assembly in the system must be connected to the power system safety ground.

EMI grounding

Chassis grounding is achieved with a connection in the upper left corner of each chassis which should be connected to the swing frame or fixed frame. The rear of each chassis is fitted with a ground bar which is used as a ground point for the I/O cables connected to the chassis. The ground terminal on the swing frame or fixed frame in the system should be connected to a ground bar using suitable size wire.

Heat Dissipation

Heat is dissipated from the system using fan trays above each chassis. Each fan tray has four vertically mounted fans designed to draw air in via vents and exhaust it into the rear of the cabinet. Fan units mounted in the roof of the cabinet are designed to exhaust the air upwards and out of the cabinet.

For calculating the heat rise inside enclosures, the following typical heat dissipation figures may be used.

Module	Heat Dissipation Value
Power Pack	Must be calculated – Depends upon load
TMR Processor	80 W
Communications Interface	10 W
Expander Interface	40 W
Expander Processor	40 W
I/O Modules	Up to 24 W Refer to the associated PD

Table 1: Maximum Module Heat Dissipation Values

Module Weights

Ensure that the mounting location can support the weight before mounting the Controller or Expander Chassis using the figures in Table 2 as a guide.

Module	Weight
Controller chassis	5.00kg (11lbs)
TMR Processor	2.71kg (5.95lbs)
Expander Interface	1.14kg (2.51lbs)
Expander Interface Adapter	0.65kg (1.43lbs)
Communications Interface	1.23kg (2.71lbs)
Communications Interface Adapter	0.42kg (0.92lbs)
Fan tray	1.80kg (3.97lbs)
Expander Chassis	5.00kg (11lbs)
Expander Processor	1.33kg (2.93lbs)
I/O Modules	Up to 1.36kg (3.00lbs) Refer to the associated PD
Power shelf	4.40kg (9.68lbs)
Power pack	2.70kg (5.94lbs)

Table 2: Component Weights

Installing Chassis

Chassis are normally installed in swing frames to allow easy access to the rear of the chassis for various connections.

Chassis Dimensions

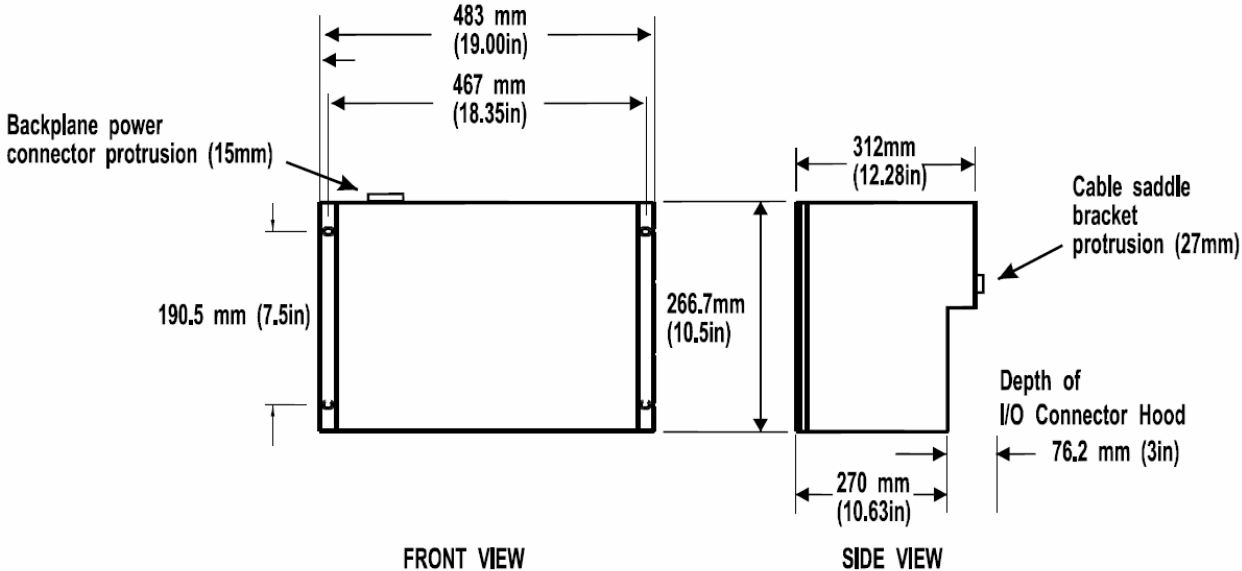

Figure 4-1: Controller and Expander Chassis Dimensions

The fan tray (T8720) dimensions are:

- Height: 88mm (3.46ins)
- Width: 483mm (19ins)
- Depth: 267mm (10.5ins)

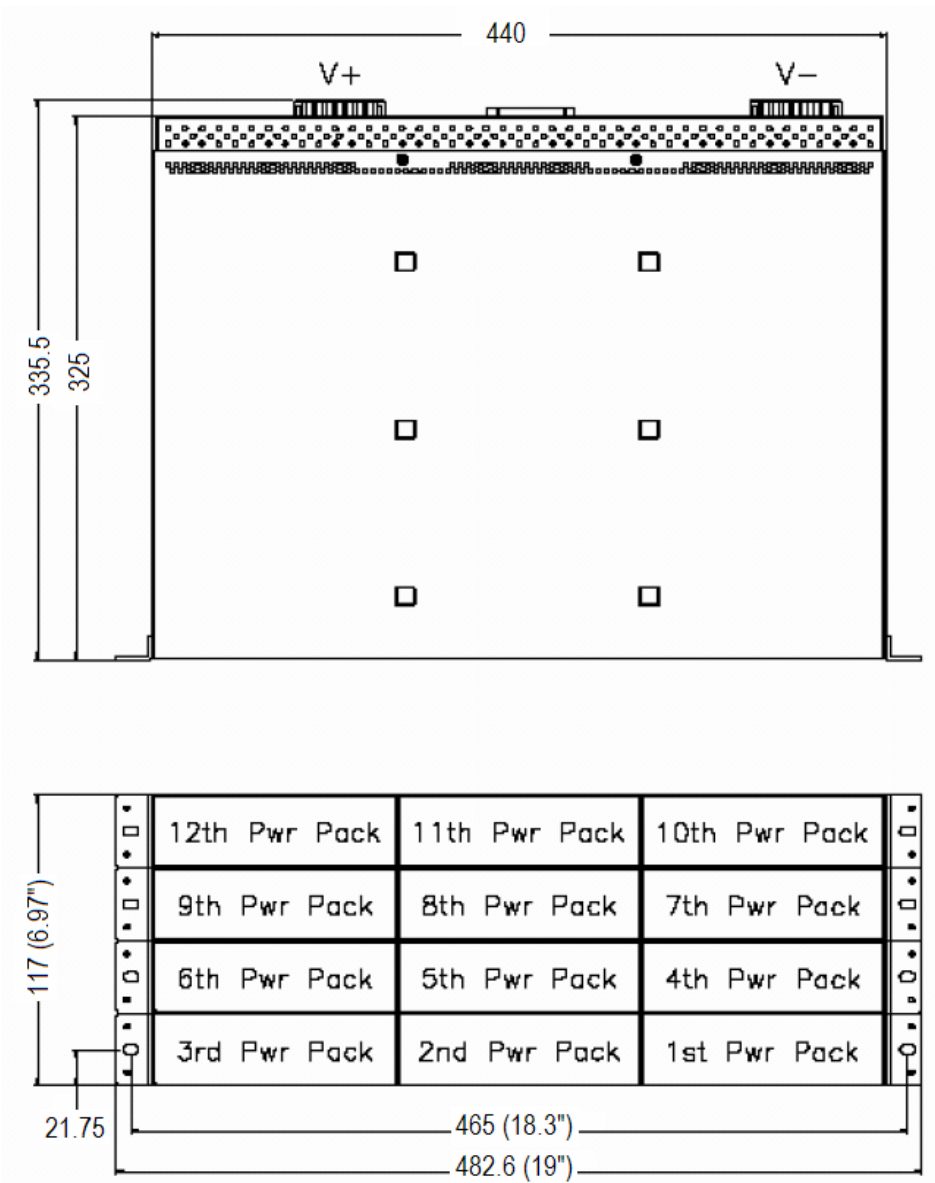

Figure 4-2: Power Shelf Dimensions

Ensure that space is provided for the installation of fan trays T8270 above each module chassis. Fan trays are 2U (88mm) high.

Note that only the inner pair of holes in the mounting ears are used at this stage to secure the chassis in the swing frame. The outer holes are used to fit the plastic fascia ears once all chassis and fan trays are fitted and alignment is correct, as shown in Figure 4-4



Figure 4-3: Controller Chassis Installation

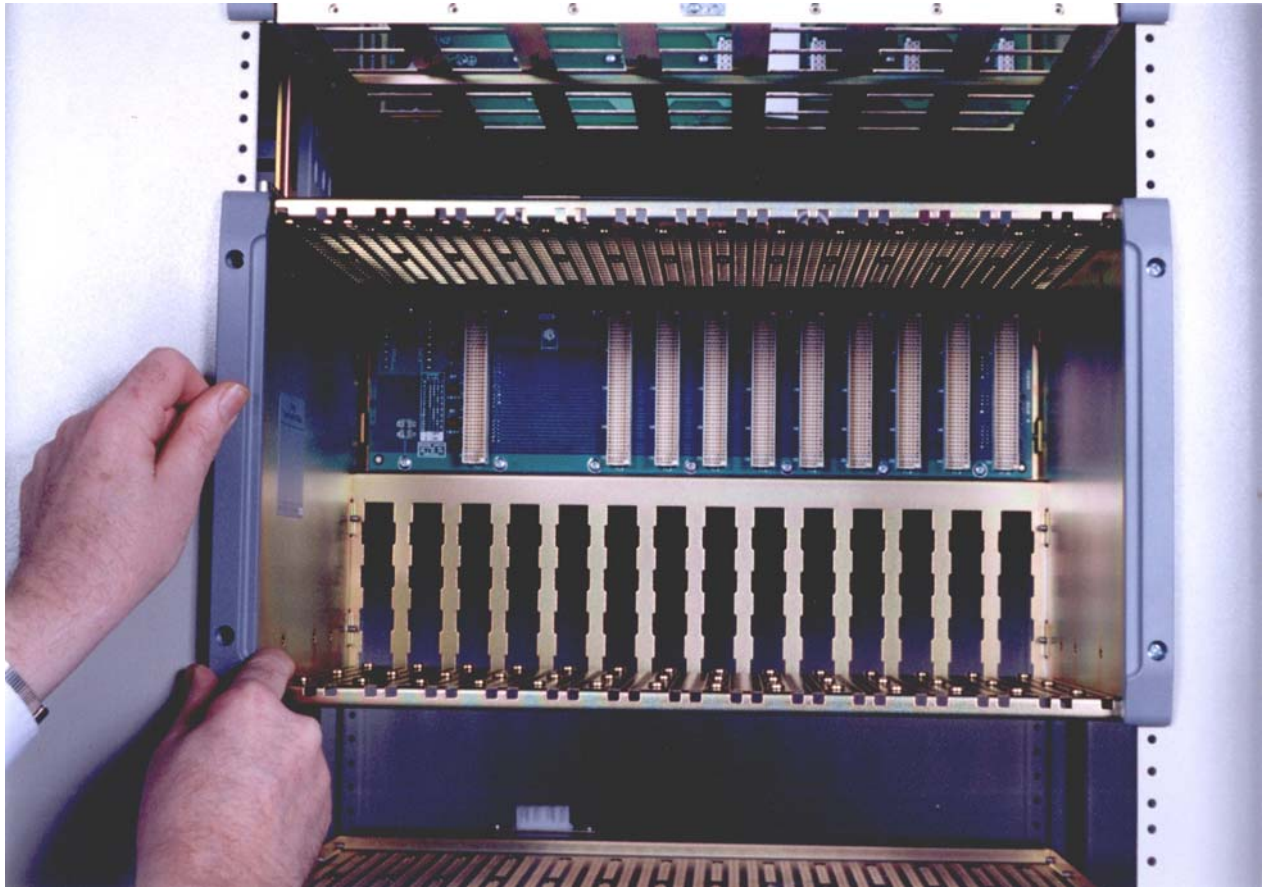

Figure 4-4: Chassis Facia Ears Installation

Chassis Power



Figure 4-5 shows a TC-001 24V dc power cable used to supply power to the Controller and Expander Chassis. The cable is usually cut to provide flying leads (in lieu of the connector shown in the left side of Figure 4-6 below) to connect to the panel power distribution.

Figure 4-5: Chassis Power Connection

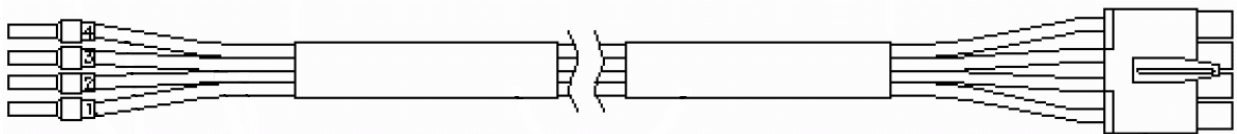

Figure 4-6: TC-001 Chassis Power Cable

Installing Fan Trays

Fan trays are used to draw air through each chassis and deflect it into the void at the rear of the swing frame. Four fans are mounted vertically at the rear of the tray. An angled deflector plate directs air towards the fans.

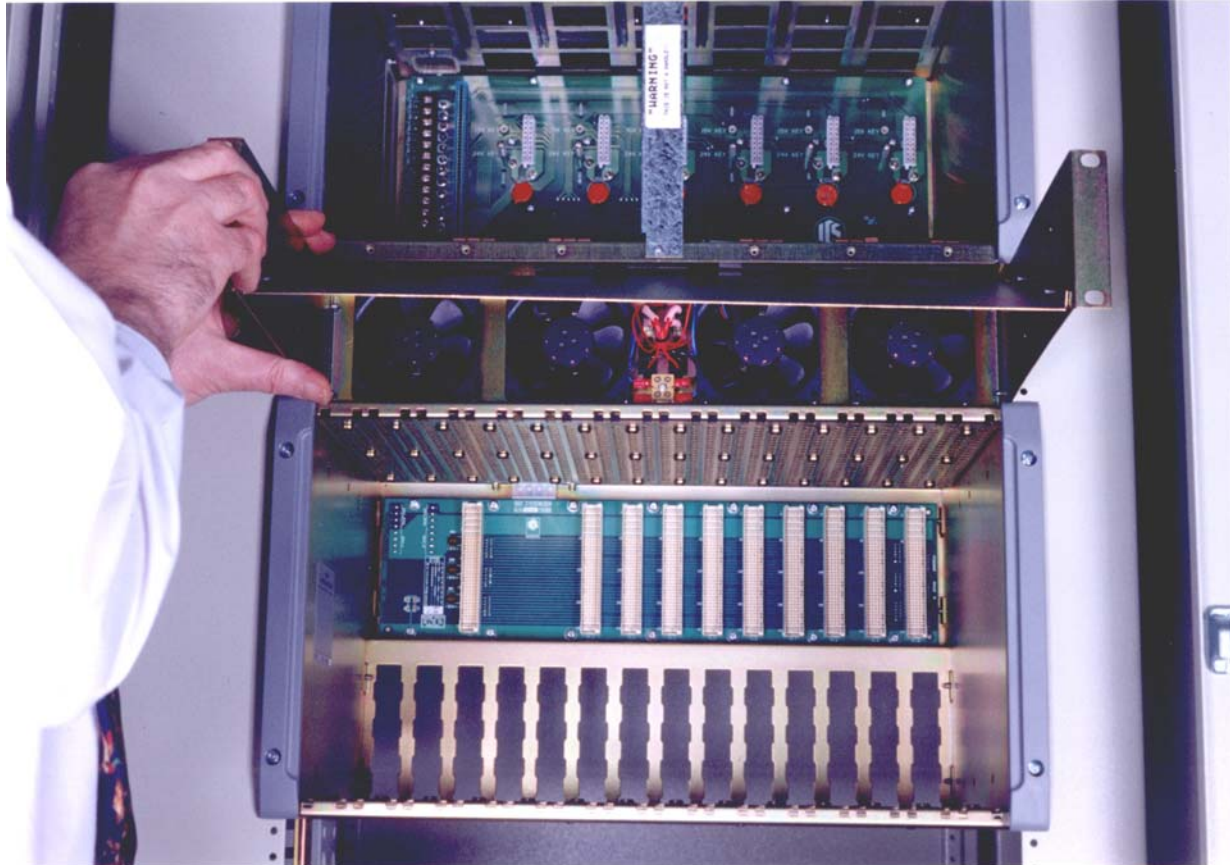

Figure 4-7: Fan Tray Installation

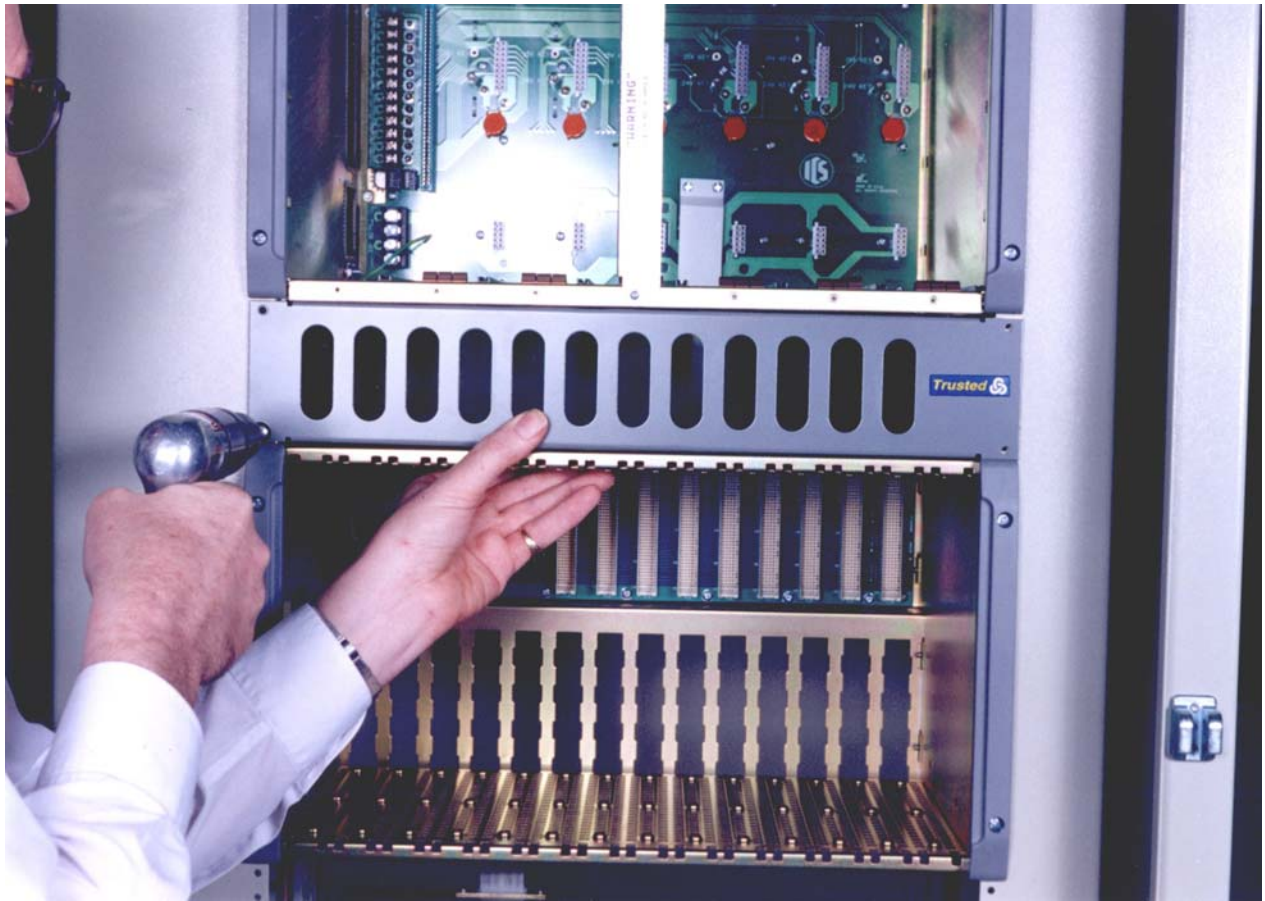

Figure 4-8: Fan Tray Grill Installation

Fan Tray Power

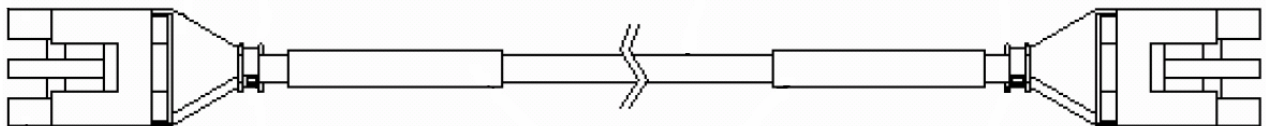

Figure 4-9: TC-011 Fan Assembly Power Cable

Cable TC-011 is used to connect redundant power to the fan trays. A six meter cable can be cut to provide flying leads to connect to the cabinet power distribution. There are four wires in the cable. The top and bottom wires (1 and 4) are 24V. The middle two wires (2 and 3) are 0V. The socket end is then connected to a fan assembly. A cable with sockets at both ends can be used to daisy-chain multiple fan assemblies, including a roof mounted fan tray. Up to six fan assemblies may be connected to a single power circuit.



Figure 4-10: Connecting Power to a Fan Assembly



Figure 4-11: Roof Mounted Fan Tray

The roof mounted fan tray is designed to exhaust the air above a cabinet. One tray is typically installed per cabinet bay. The assembly contains eight fans and can move a total of 552 m³/hr of air.

Field Termination Assemblies (FTAs)

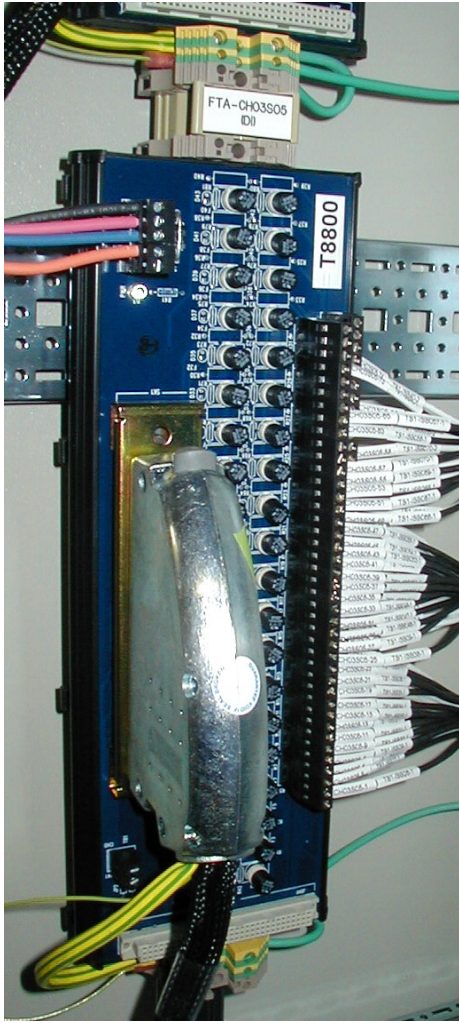

Figure 4-12: Field Termination Assembly

Field termination assemblies are used to connect field devices to the Trusted system. There are a wide variety of FTAs available depending upon the field signal type and I/O module to be interfaced with. What follows are some typical examples.

FTAs are mounted on DIN rails. They may be mounted horizontally or vertically.

40 Channel 24 Vdc Digital Input FTA (T8800)

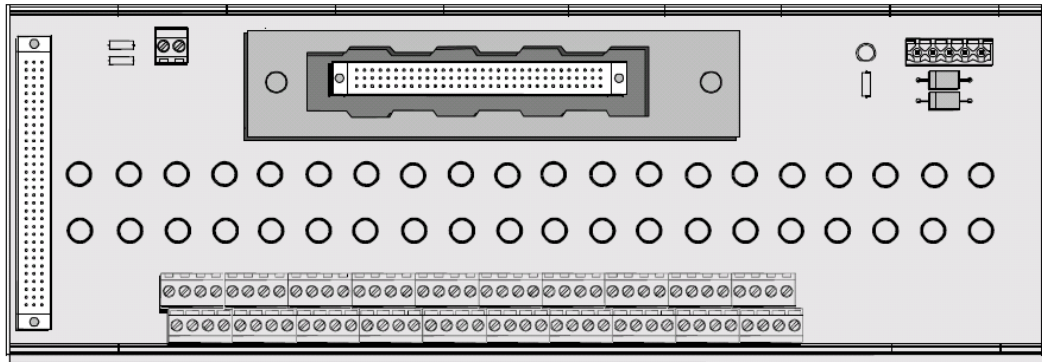

Figure 4-13: Digital Input FTA

The 24 Vdc digital input FTA, shown in Figure 4-13, is designed to act as the main interface between a field device generating a digital signal and 24 Vdc digital input module T8403.

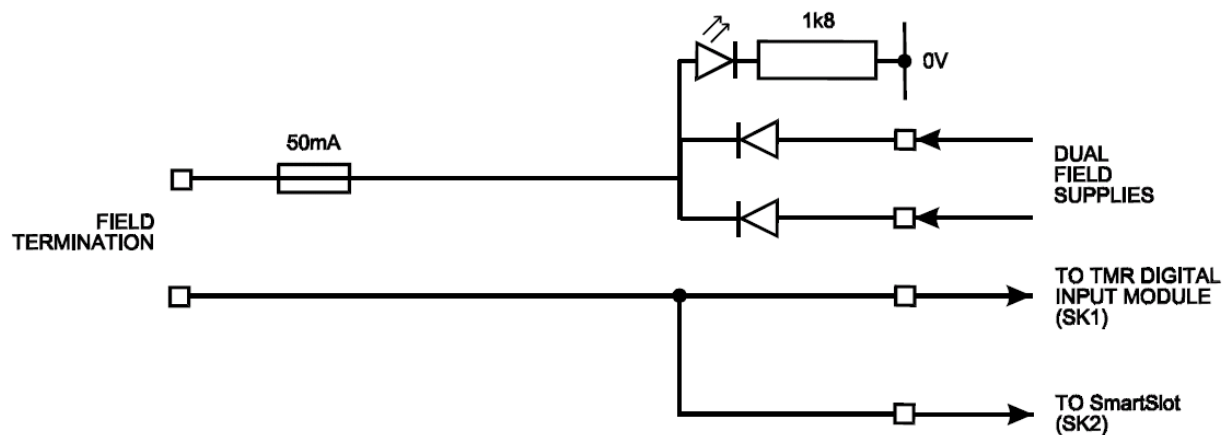

Figure 4-14: Single Channel Schematic for Digital Input FTA

Power for the field is supplied from dual 24 Vdc feeds which are commoned via diodes on the FTA. Indication of power is provided by a green LED.

The supply voltage to the field is fed via the 50mA fuse. This effectively limits the current in the field loop. The incoming signal (digital) from the field device is fed directly to the digital input module. Line monitoring components (if required) provide the necessary thresholds used by the input module to detect the field loop/device status, i.e. open/short circuit, alarm etc.

The cable linking the 40 channels on the input module to the FTA is terminated at the 96-way socket SK1.

40 Channel 24 Vdc Digital Input FTA Non-Incendive (T8801)

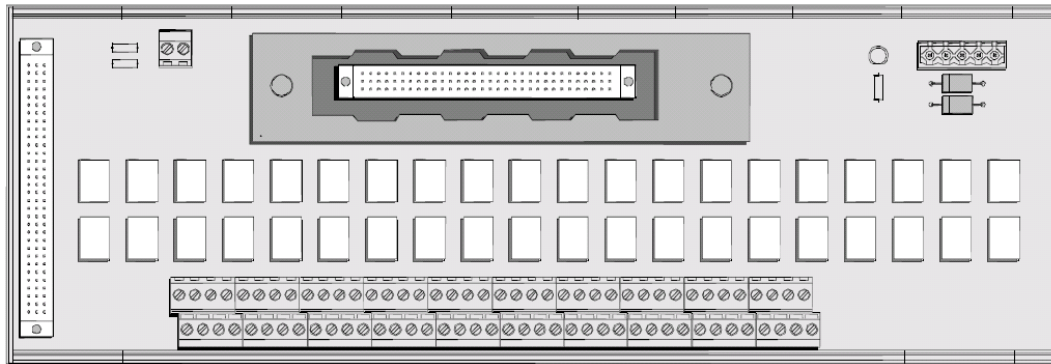

Figure 4-15: Non-Incendive Digital Input FTA

The non-incendive 24Vdc digital input FTA, shown in Figure 4-15, is designed to act as the main interface between a non-incendive field device in a hazardous area generating a digital signal and 24Vdc digital input module T8403.

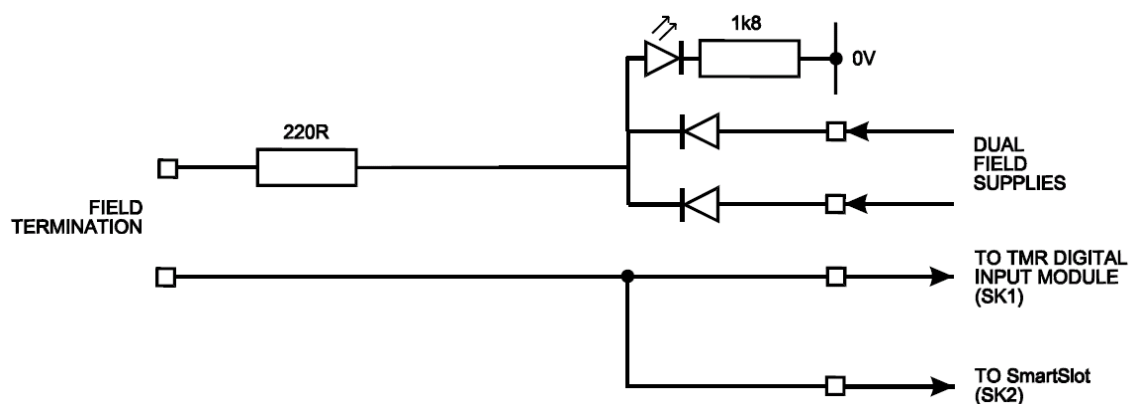

Figure 4-16: Single Channel Schematic for Non-Incendive Digital Input FTA

Power for the field is supplied from dual 24V dc feeds which are commoned via diodes on the FTA. Indication of power is provided by a green LED.

The supply voltage to the field is fed via the 220Ω resistor. This effectively limits the current in the field loop allowing inputs from non-incendive field devices located in hazardous areas. The incoming signal (digital) from the field device is fed directly to the digital input module. Line monitoring components (if required) provide the necessary thresholds used by the input module to detect the field loop/device status, i.e. open/short circuit, alarm etc.

The cable linking the 40 channels on the input module to the FTA is terminated at the 96-way socket SK1.

40 Channel Analog Input FTA (T8830)

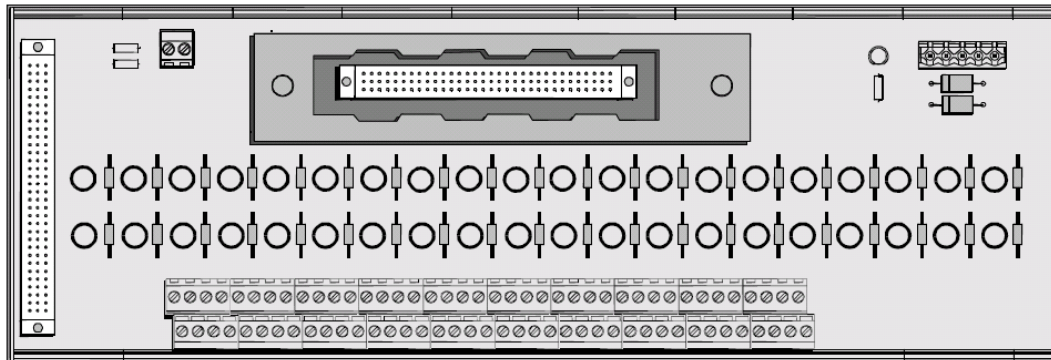

Figure 4-17: Analog Input FTA

The 40 channel analog input FTA, shown in Figure 4-17, is designed to act as the main interface between a field device generating an analog signal and analog input module T8431.

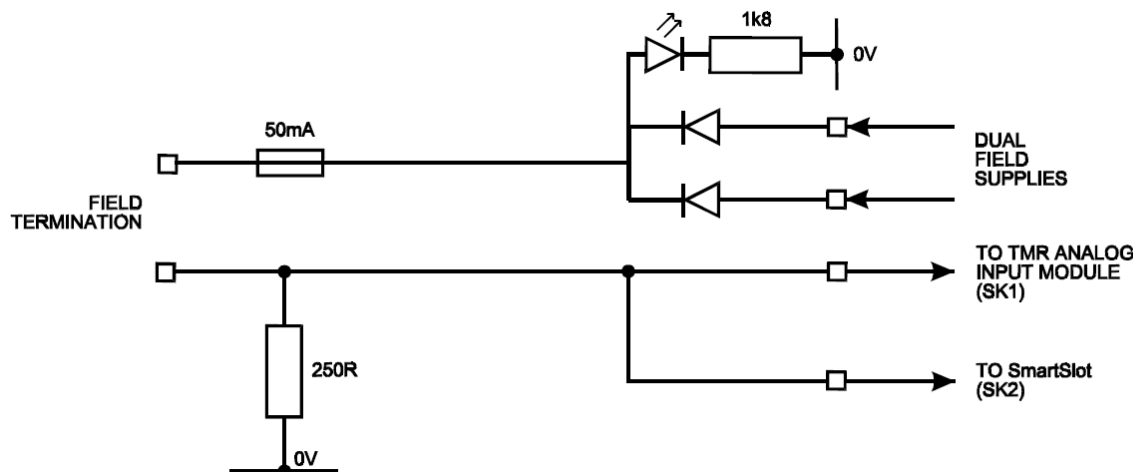

Figure 4-18: Single Channel Schematic for Analog Input FTA

Power for the field is supplied from dual 24V dc feeds which are commoned via diodes on the FTA. Indication of power is provided by a green LED.

The supply voltage to the field is fed via the 50mA fuse. This effectively limits the current in the field loop. The voltage developed across the 250Ω resistor due to the incoming analog signal from the field device is fed directly to the analogue input module.

The cable linking the 40 channels on the input module to the FTA is terminated at the 96-way socket SK1.

40 Channel Analog Input FTA Non-Incendive (T8831)

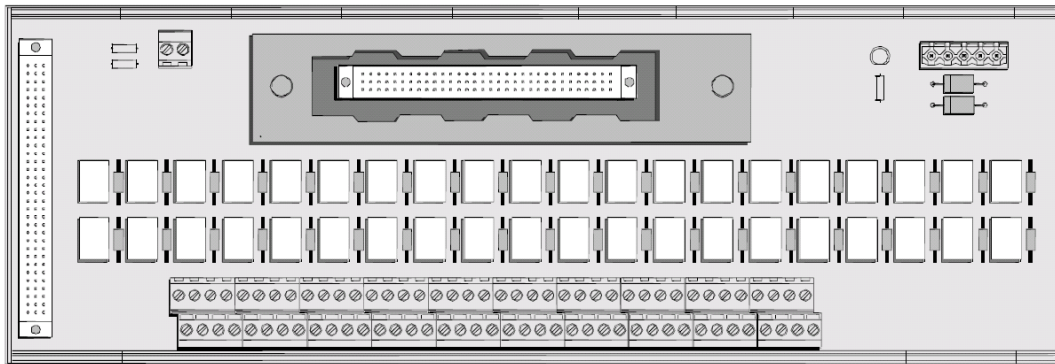

Figure 4-19: Non-Incendive Analog Input FTA

The 40 channel non-incendive analog input FTA, shown in Figure 4-19, is designed to act as the main interface between a non-incendive field device in a hazardous area generating an analog signal and analog input module T8431.

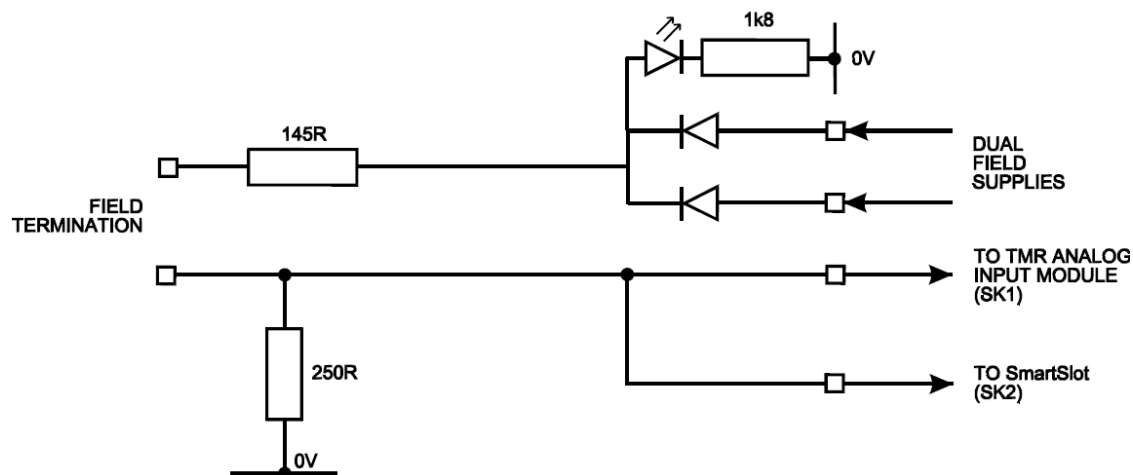

Figure 4-20: Single Channel Schematic for Non-Incendive Analog Input FTA

Power for the field is supplied from dual 24V dc feeds which are commoned via diodes on the FTA. Indication of power is provided by a green LED.

The supply voltage to the field is fed via the 145 Ω resistor. This effectively limits the current in the field loop allowing inputs from non-incendive field devices located in hazardous areas. The voltage developed across the 250 Ω resistor due to the incoming analog signal from the field device is fed directly to the analog input module.

The cable linking the 40 channels on the input module to the FTA is terminated at the 96-way socket SK1.

40 Channel Analog or Digital Output FTA (T8850)

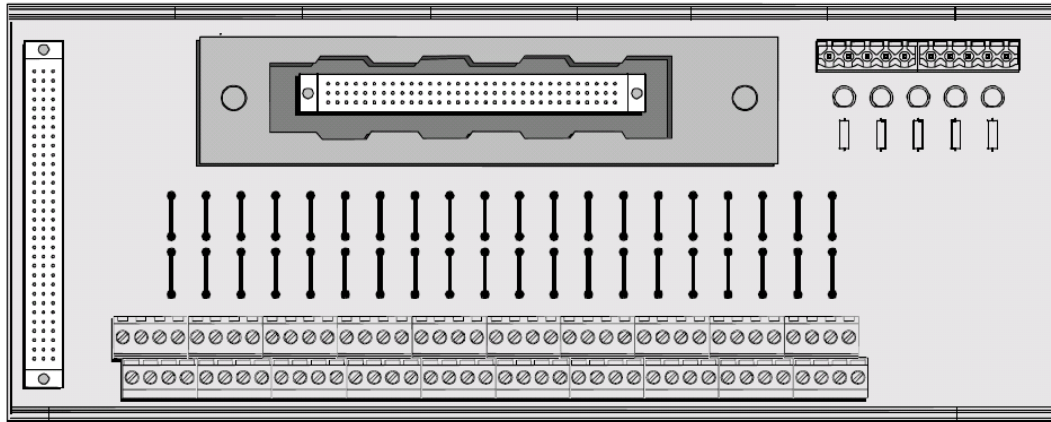

Figure 4-21: Analog or Digital Output FTA

The 40 channel analog output or digital output FTA, shown in Figure 4-21, is designed to act as the main interface between 24 Vdc digital output module T8451/61 or analog output module T8480 and the field device. The signal from the output modules are 24 Vdc and 0-20 mA respectively.

Field connections for 0V and 24V are connected to the terminal strips. The 40 channels are arranged in five groups each comprising eight identical channels. Return 0V is connected from a bus bar to the FTA via a 10-way terminal block. 24V is fed directly to the output module from the T8290 output power distribution unit (described below). Figure 4-22 shows the configuration of two channels within a group.

The cable linking the 40 channels on the output module to the FTA is terminated at the 96-way socket SK1.

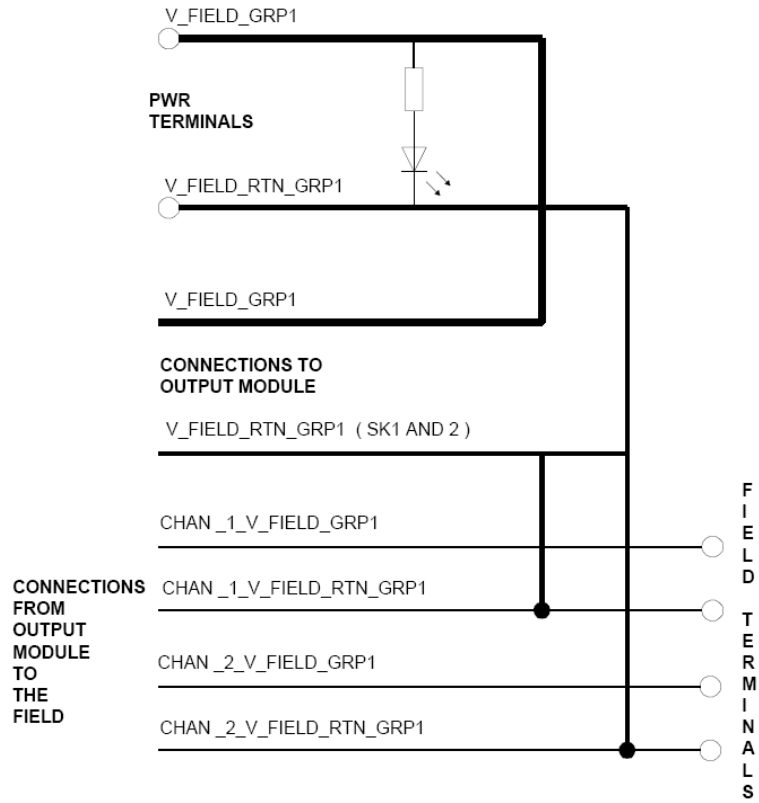

Figure 4-22: Two Channel Schematic for T8850 FTA

Companion and Smart Slot I/O Module Arrangements

In a companion slot configuration, two adjacent slots in a chassis are dedicated for the same module function. One slot is the primary and the other a unique secondary (or spare). The two slots are joined at the rear of the chassis with a double-wide I/O interface cable that connects both slots to common field wiring terminations. During normal operations, the primary slot contains the active module as indicated by the *Active* indicator on the front panel of the module. The secondary slot is available for a spare module that will normally be the standby module as indicated by the *Standby* indicator on the front panel of the module.

Depending on the installation, a hot-spare module may already be installed, or a module blank will be installed in the standby slot. If a hot-spare module is already installed, transfer to the standby module occurs automatically when a module fault is detected in the active module. If a hot spare is not installed, the system continues operating from the active module until a spare module is installed.

For a smart slot configuration, the secondary slot is *not* unique to each primary slot. Instead, a single secondary slot is shared among many primary slots (usually within a single chassis). This technique provides the highest density of modules in a given physical space. At the rear of the Trusted chassis, a single-width input jumper cable can be used to connect the secondary slot directly to the rear of the cable connecting the failed primary module and its field termination assembly. With a spare module installed in the smart slot and the smart slot I/O cable connecting the two module slots, the smart slot can be used to replace the failed primary module.

I/O Companion and Smart Slot Cables

Companion and smart slot cables provide connection facilities between I/O modules and field termination assemblies (FTAs). There are a wide variety of cables available depending upon the I/O module and FTA used. Please refer to PD-TC200 and PD-TC500 for further details. Standard cables are 15 feet for internal grade and 28feet for external grade, but other lengths may be specified. Cables are also available with a flying lead at one end to allow connection to conditioned terminals.

Companion slots are used when partner I/O modules are side by side. Figure 4-23 shows both ends of a typical companion slot cable. The single wide hood connects to the FTA. The double wide hood connects to the rear of the chassis. Figure 4-24 shows one example of a companion slot cable.

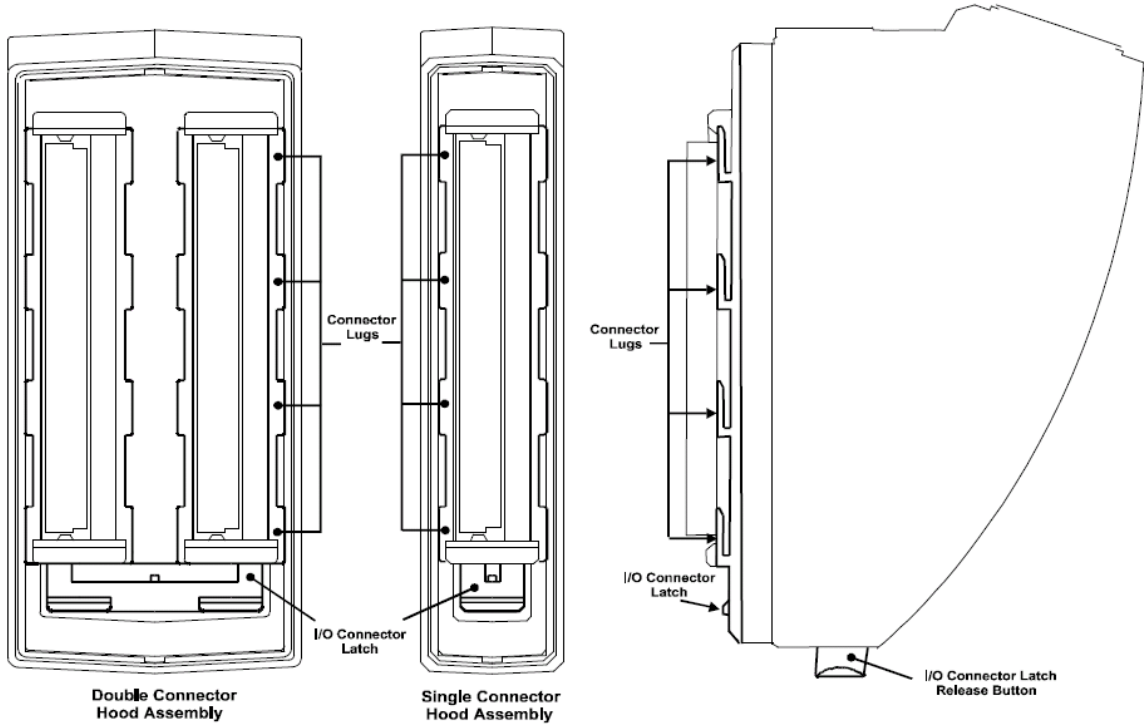

Figure 4-23: I/O Connectors

The smart slot arrangement is used when an I/O module slot is used to replicate any module located anywhere in the system. Figure 4-23 shows one example of a smart slot cable. Both ends are single width.



Figure 4-24: Typical Companion Slot Cable



Figure 4-25: Typical SmartSlot Cable



Figure 4-26: View of SmartSlot Connectors

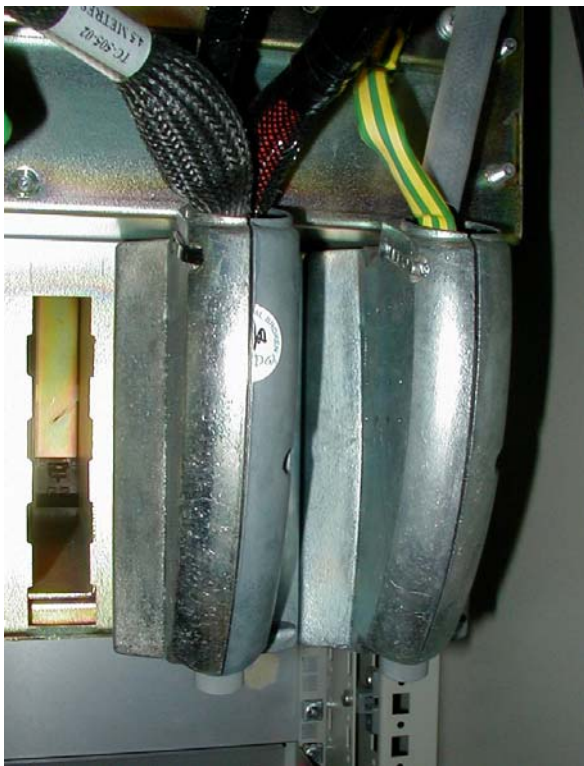

Figure 4-27: View of Companion Slot Connectors

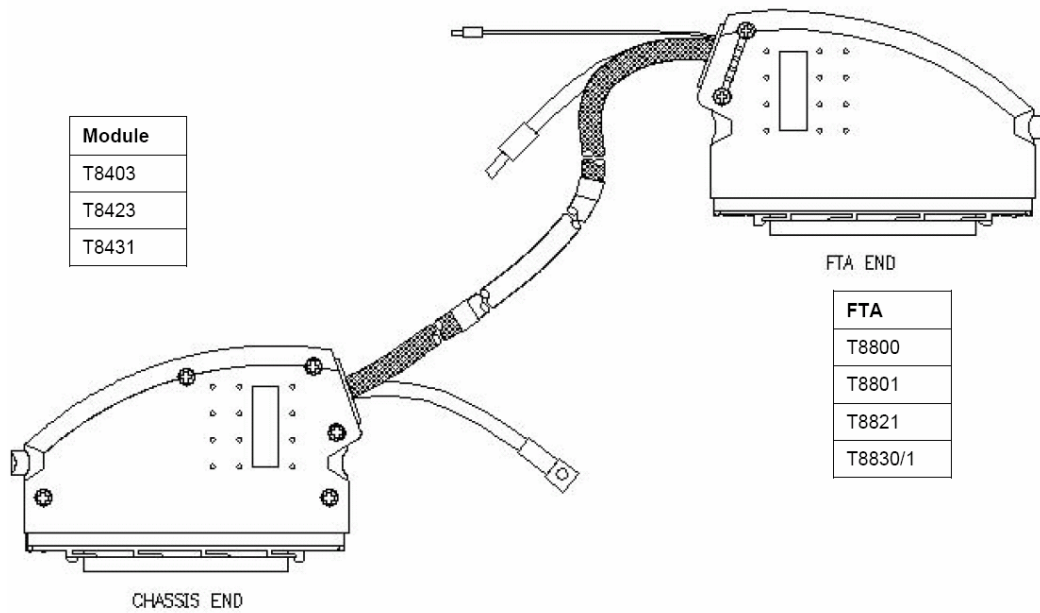

Figure 4-28: TC-201 Input Companion Slot Cable

Figure 4-28 shows a typical cable for inputs. Figure 4-29 shows a typical cable for outputs. Note the additional connections coming from the output chassis hood to the T8290 output power distribution unit (described below).

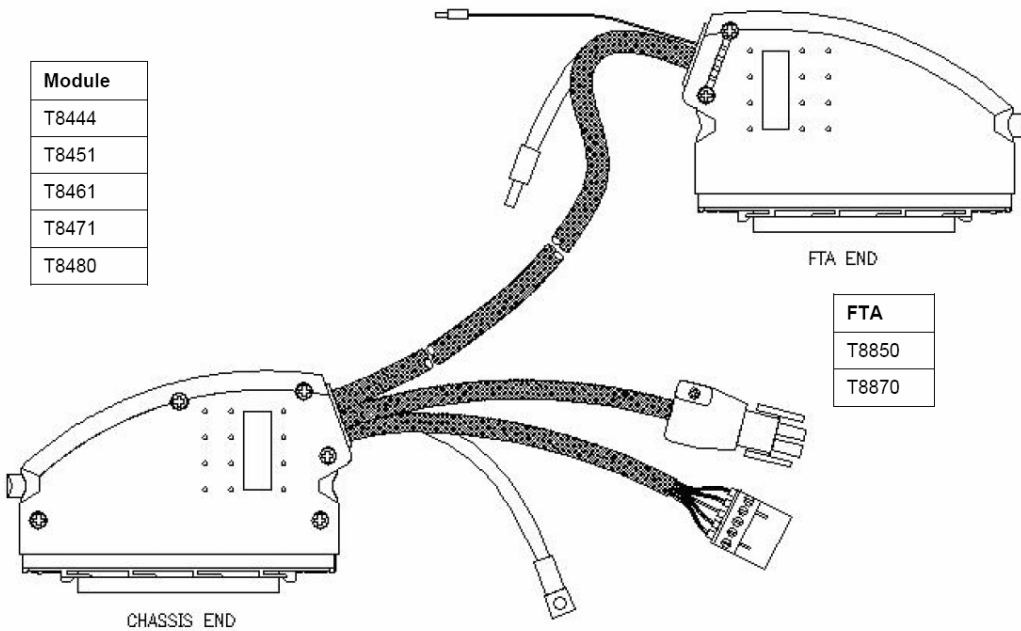

Figure 4-29: TC-205 Output Companion Slot Cable

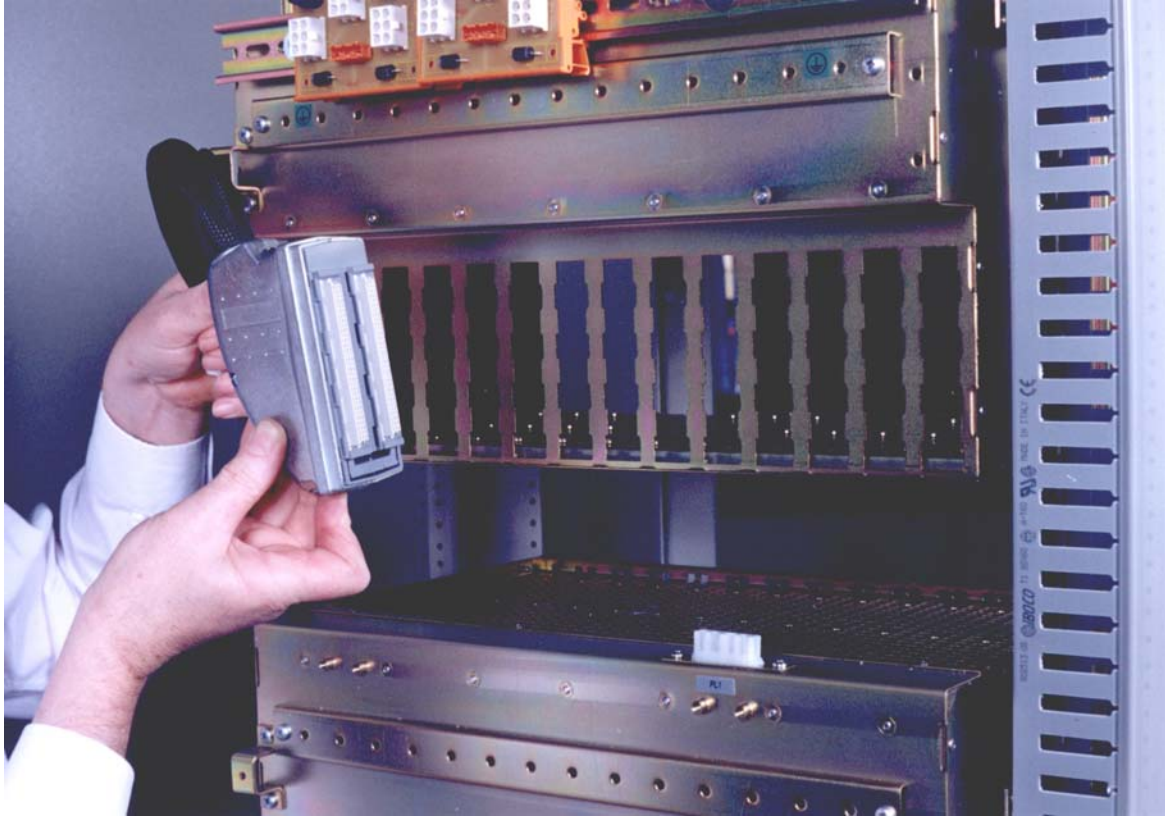

Figure 4-30: Connecting a Companion Slot Connector (1 of 2)

To install one end of the cable to the rear of a Controller or Expander chassis:

1. Identify the correct location where the I/O module will be installed
2. Ensure the slot is not occupied by a module
3. Line up the tabs on the connector with the slots in the chassis
4. Insert the connector into the chassis
5. Slide the connector up until it snaps in place.

To remove the connector, press the release button on the bottom of the connector and slide the connector down to release it.

Note: The connector cannot be installed or removed with an I/O module or shield (blank) installed in either slot.

The other side of the cable connects to the Field Termination Assembly in a similar manner.

Smart slot cables connect in the same manner. The only difference is that the connector at the chassis end is a single width connector.

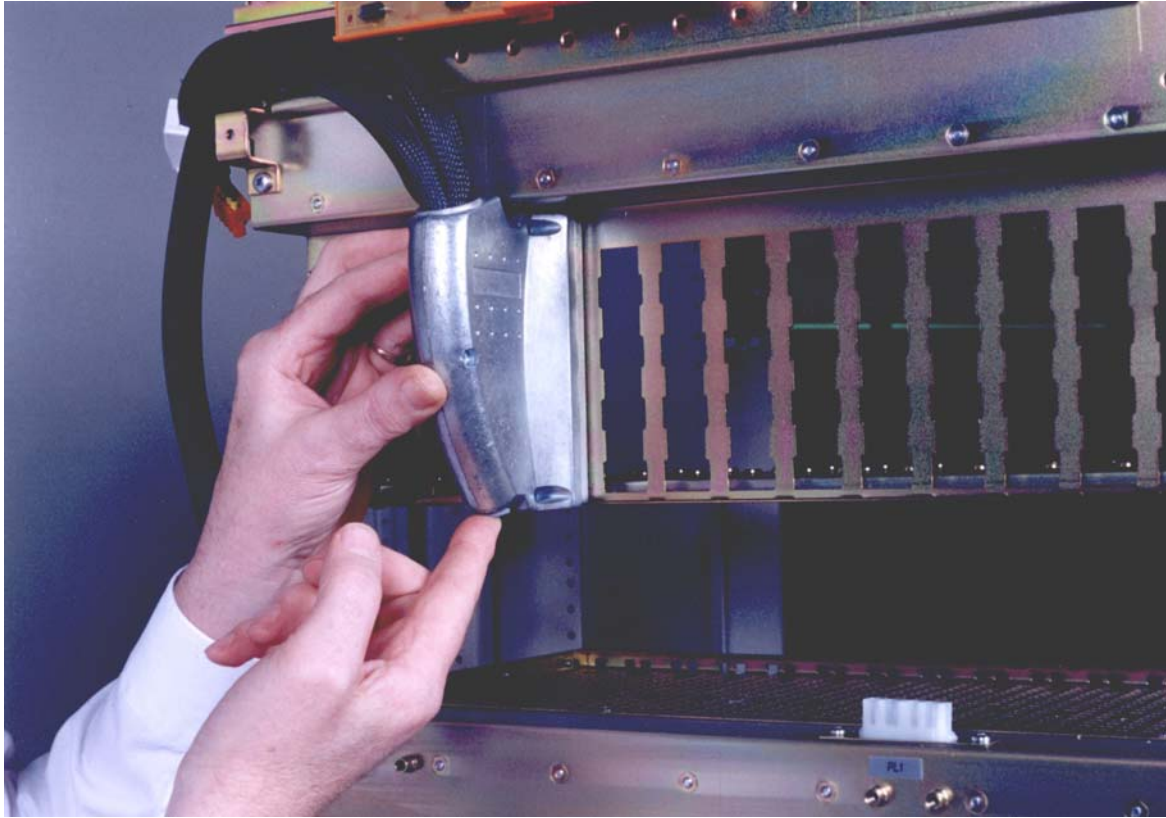

Figure 4-31: Connecting a Companion Slot Connector (2 of 2)

Output Field Power

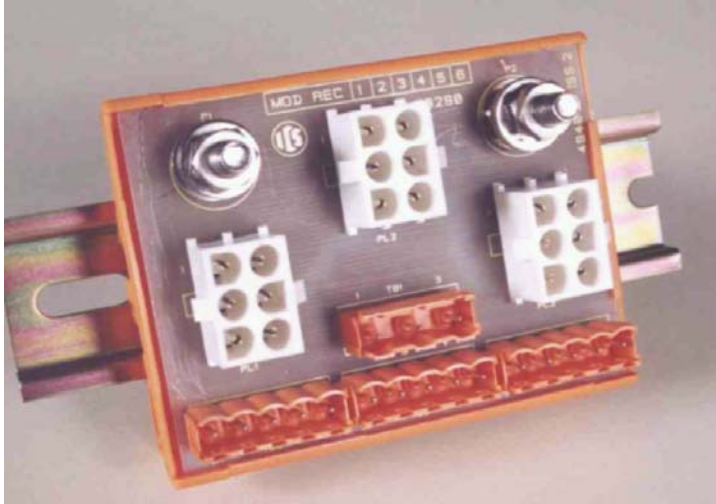

Figure 4-32: T8290 Output Power Distribution Unit

The T8290 Output Power Distribution Unit is designed to provide 24-120V dc for use with sourcing output modules (T8451 24VDC DO, T8461 24/48VDC DO, T8471 120VDC DO, T8480 AO). The unit is designed to be mounted on a DIN rail above the relevant output module I/O connectors.

Figures 4-32/33/34 show the various power connections. The white connectors on the T8290 are 24-120V. The orange connectors are the 0V reference.

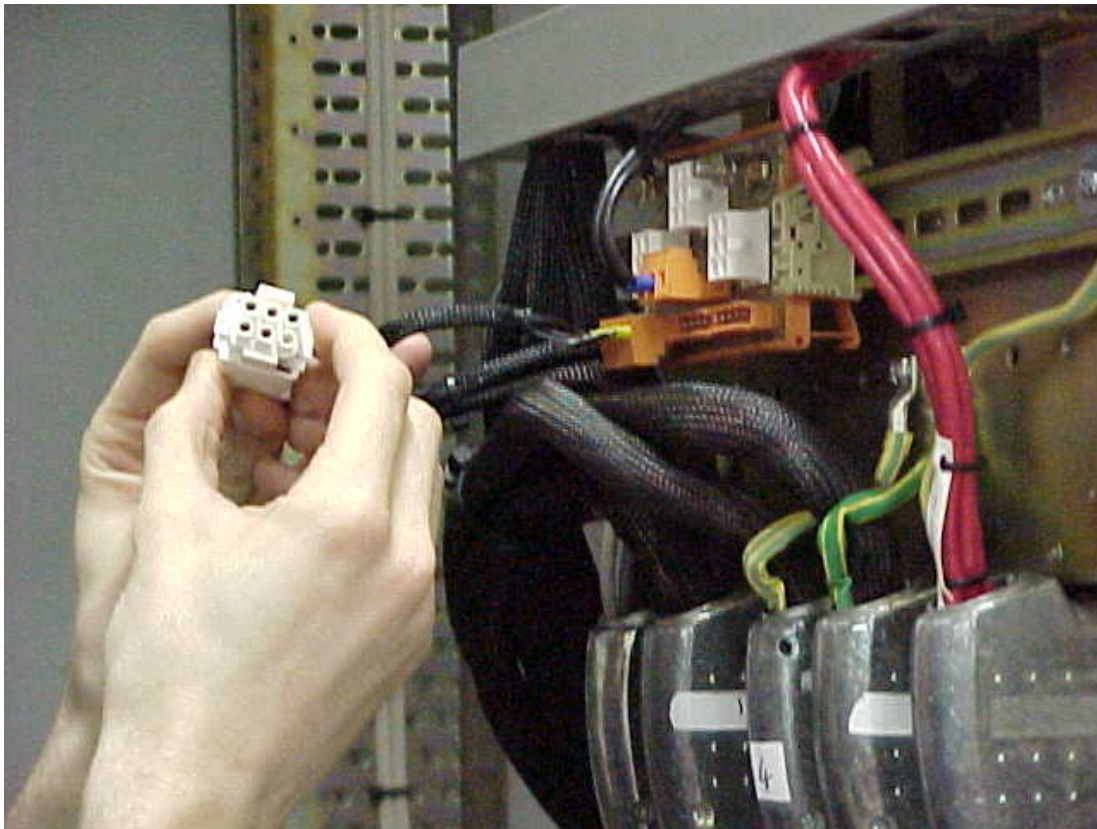

Figure 4-33: Output Field Power Connection

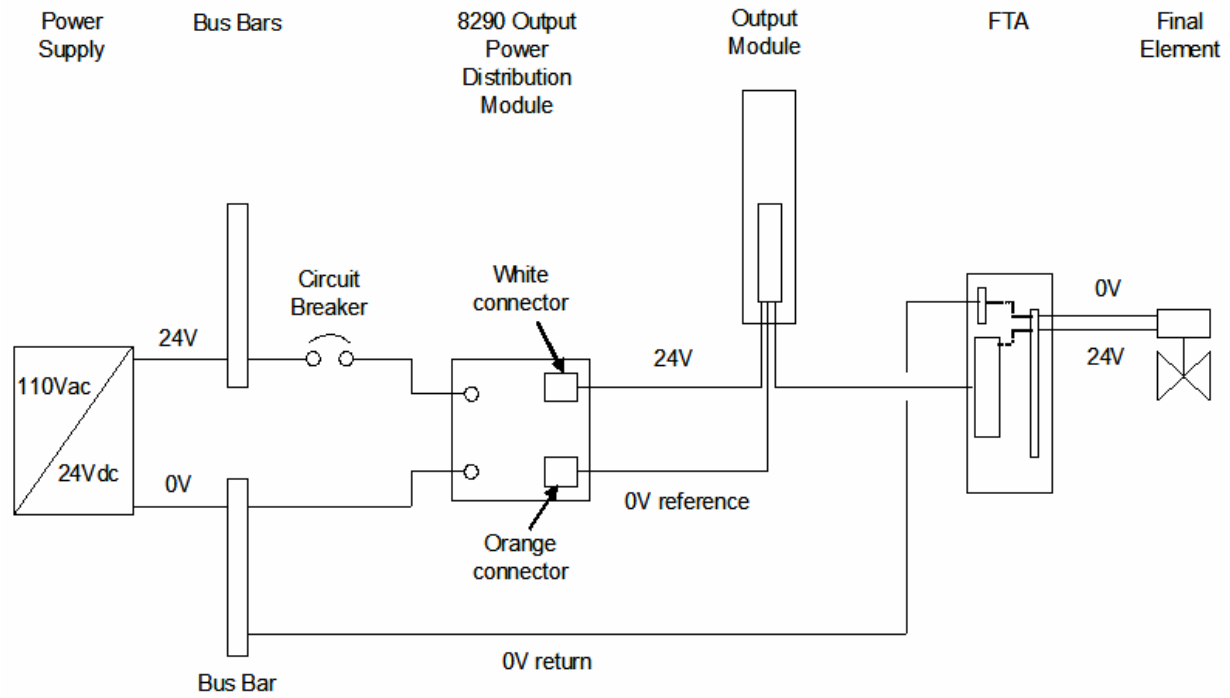

Figure 4-34 Output Power Connections

Installing Modules



Figure 4-35: Module Installation

In general, to install a module:

- 1) Insert the special release key to disengage the two ejector levers on the top and bottom front faceplate of the module.
- 2) Rotate the two ejector levers outward to fully disengage them.
- 3) Hold the module and ejector levers and insert the module into its chassis slot. The modules are self-aligning.
- 4) Slide the module into the chassis and press it firmly in place.
- 5) Press the two ejector levers flush with the module faceplate.

Interlock switches are provided on the ejector levers to detect removal of the module.

Shields

Shields (module blanks) are fitted with baffle plates designed to direct air flow through actual modules. All unoccupied module slots *must* be fitted with shields.

- T8191 – Single-width slots
- T8193 – Triple-width slots

This page intentionally left blank.