

SYNCHROTECT 6

Optimum reliability

A synchronizer is expected under no circumstances to close the circuit-breaker under non-synchronous conditions and still ensure the availability of a plant by always closing the circuit-breaker when required.

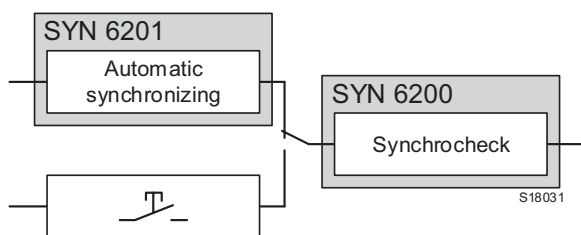

The series connection of the output contacts of a dual-channel system significantly increases safety of the plant, but this will inevitably reduce the availability of the overall system.

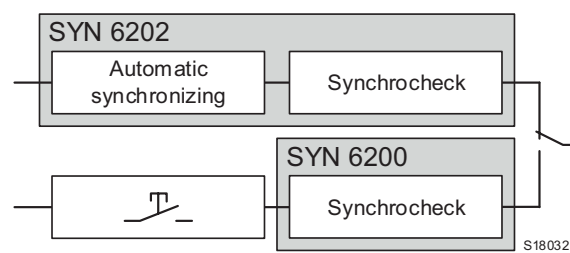

High levels of safety and availability can be achieved by using a second, redundant synchronizing system. If system 1 can no longer synchronize, it is still possible to do so by switching over to the second system.

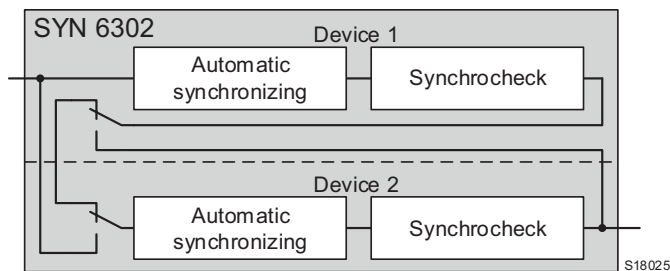

In this configuration, two automatic dual-channel devices are used. Normally, the output contacts of both devices are connected in series (4 channels!). One of the two devices can be by-passed by means of the device selector switches on each device, or remotely by a control signal. The defective device may be removed (eg, for repair) while the other remains in service.

SYNCHROTACT 6

Optimum reliability

Advice

Single- or dual-channel?

Not every synchronizing system needs to be structured according to the configuration examples for reliability mentioned above.

The SYNCHROTACT 6 single-channel synchronizing devices, which are very often used, offer a high degree of safety. However, safety can be significantly increased by means of dual-channel systems with an independent synchrocheck connected in series.

It is unlikely that both channels, of which the hardware and software are structured differently, will suffer the same malfunction simultaneously. The extra cost of a dual-channel system can prove beneficial compared to the damage arising from incorrect paralleling.

For all generators in the MW range, ABB strongly recommends using an independent synchrocheck with its output contacts connected in series with the automatic synchronizer. The SYNCHROTACT 6 Diverse Dual Channel devices offer such a configuration in a single device and provide additional safety functions between both channels, in order to follow the IEC 61508 SIL requirements for functional safety.

Second, redundant synchronizing system?

Often, two redundant synchronizing systems are installed in a single plant so that if one system fails the other can be used, thereby increasing availability. The second system is often designed for manual synchronizing with or without synchrocheck.

In addition, with SYNCHROTACT 6 type SYN 6302, ABB offers two automatic dual-channel devices, building one redundant system. This makes it possible to dispense with manual synchronizing.

Advantages of such a solution:

- Lower engineering and wiring costs for the additional second device.
- Further increased safety since all four output contacts are normally operated in series.

SYNCHROTECT 6

The twenty-in-one synchronizing device

Specific settings for synchronizing and paralleling are stored in a parameter set. Devices with twenty parameter sets have twenty times the same parameters, with the possibility of individual setting. That way, twenty paralleling points with individual settings may be operated. Firstly, the parameter set or the circuit breaker to be synchronized has to be selected. Then the synchronizing process can be started.

The software-driven link between parameter set and paralleling point guarantees the correct assignment of the setting values to the related plant components. Maximum 13 binary inputs and 11 relay outputs are available for the selection. If more parameter sets or paralleling points are required, peripheral devices must be used, but these are not yet available.

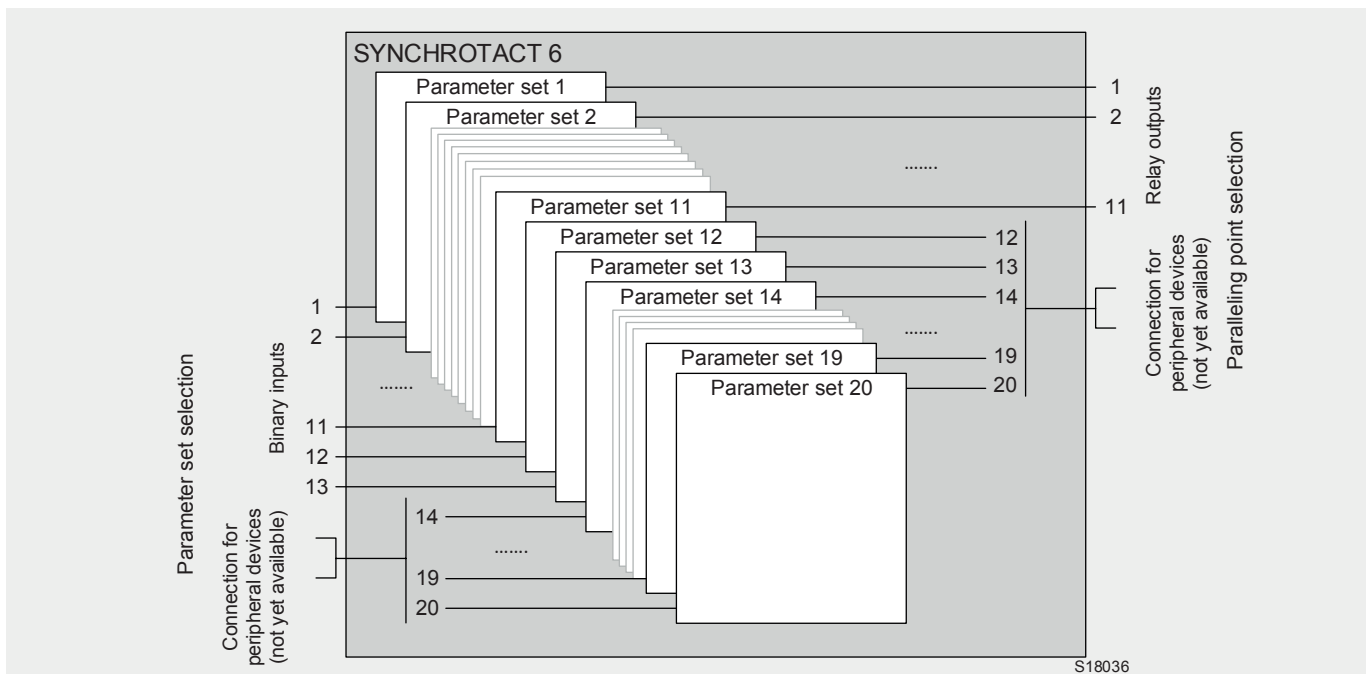

Parameter set and paralleling point selection

Control options

Maintenance control for commissioning and servicing

- Built-in Maintenance Control Panel (MCP)
- SynView 6 PC-tool

Operating control for normal synchronizing operation

- Binary inputs/outputs: conventional wiring (standard)
- Communication interfaces: IEC 61850 electrical or optical; Modbus RTU; Profibus DP (option)

SYNCHROTACT 6

Device types

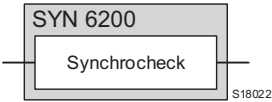
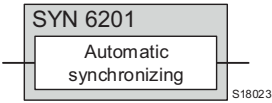
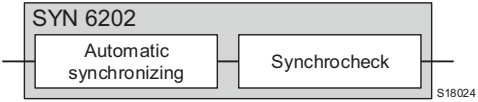
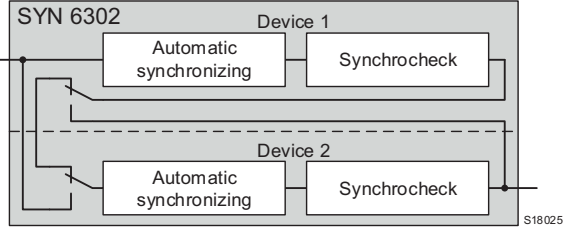
Type	Function	Symbol
SYN 6200	Synchrocheck or automatic paralleling unit without matching function	
SYN 6201	Automatic single-channel synchronizing device	
SYN 6202	Automatic dual-channel synchronizing device	
SYN 6302	Redundant automatic dual-channel synchronizing system	

Differences between SYN 6302 and SYN 6202

The SYN 6202 is a dual-channel system with two differently structured independent channels used as one functional system.

SYN 6302 consists of two "SYN 6202" dual-channel devices used as a redundant system. The output contacts of both devices are normally wired in series (four channels!). If one device fails, a safe switchover to the other device is possible by bypassing it. This allows paralleling to be carried out fully automatically and with maximum safety at all times. If repair or replacement of the defective device is needed, it can easily be removed from the system.

Remark: the simpler SYN 5100 from the SYNCHROTACT 5 family is not replaced. It can however be used in combination with the SYNCHROTACT 6 devices.

Type Code

SYN 6 t 0v

Synchronizing mode

- 00: Synchrocheck
- 01: Single channel device
- 02: Dual channel device

Construction size

- 2: Medium size
- 3: Large size

SYNCHROTACT

- SYN: SYNCHROTACT
- 6: Sixth generation

S17026

SYNCHROTECT 6

Device types

Front and rear view of
 SYN 6200
 SYN 6201
 SYN 6202



Front view of
 SYN 6302





Rear view of
 SYN 6302



SYNCHROTACT 6

Functions, options and ordering details

Functions at a glance

Function	Type			
Product				
	SYN 6200	SYN 6201	SYN 6202	SYN 6302
Automatic synchronizing	Yes	Yes	Yes	Yes
Paralleling of two lines	Yes	Yes	Yes	Yes
Synchrocheck mode	Yes	Yes	Yes	Yes
Voltage matching	No	Yes	Yes	Yes
Frequency matching	No	Yes	Yes	Yes
Dual-channel system	No	No	Yes	Yes
Integrated, redundant system (bypass)	No	No	No	Yes
Number of parameter sets	either 2 or 20	either 2 or 20	either 2 or 20	either 2 or 20
Paralleling of synchronous lines	Yes	Yes	Yes	Yes
Paralleling of asynchronous lines	Yes	Yes	Yes	Yes
Paralleling of voltage-free lines	Yes	Yes	Yes	Yes
Signaling	Yes	Yes	Yes	Yes
Parameter setting by PC Tool SynView 6	Yes	Yes	Yes	Yes
Parameter setting without PC	Yes	Yes	Yes	Yes
Semi-flush mounting (standard)	Yes	Yes	Yes	Yes
Surface mounting	on request	on request	on request	on request
Top-hat rail mounting (DIN)	No	No	No	No

Options

Option	SYN 6200, SYN 6201, SYN 6202, SYN 6302
w	Communication (operating interface) 0 none 1 IEC 61850 station bus, electrical 2 IEC 61850 station bus, optical 4 Modbus RTU 5 Profibus DP
x	Internal code 2
y	Internal code 0
z	Functionality 2 Basic (2 parameter sets) 3 Extended (20 parameter sets, Tap changer control)

Device type	Options
SYN 6u0v	- wxyz

Ordering details

Examples	
SYN 6200 – 0202	Synchrocheck with two parameter sets
SYN 6201 – 0203	Automatic single-channel synchronizing device with twenty parameter sets
SYN 6202 – 1203	Automatic dual-channel synchronizing device with communication (IEC61850 electrical) and twenty parameter sets
SYN 6302 – 2203	Redundant automatic dual-channel synchronizing device with communication (IEC 61850 optical) and twenty parameter sets

SYNCHROTACT 6

Option details

Option w: Communication

Characteristics of the field bus protocols	
Supported protocols	MODBUS RTU; PROFIBUS DP
Interface type	Configurable: RS 232/RS 485
Connector type	D-Sub9 (female)
Transmitted signals	Compatible with SYNCHROTACT 5; Binary inputs/outputs; status indicators (LEDs); actual values (analog)
Addressing	Slave address depending on fieldbus

SYN 6302:

The interfaces are duplicated, ie, each device can be controlled individually. The write commands ("controls,")

Characteristics of the IEC 61850 interface	
Interface type	Ethernet
Connector type	RJ45 or LC
Transmitted signals	Digital I/Os (status information/controls); actual values (measured values)

START, STOP, Release DB and Reset must only be sent to one of the devices. Write commands for the configurable inputs (BIN) have to be given separately for each device.

Option z: Functionality

SYNCHROTACT 6 – devices with basic functionality (z = 2) contain the basic functions listed below. SYNCHROTACT 6 –

devices with extended functionality (z = 3) contain the basic and additional functions (shown below).

Basic functions:

Configurable functions of binary inputs

- Selection of parameter set or paralleling point
- Selection of TEST mode
- Starting, stopping and blocking of synchronizing process
- Device Reset

Configurable functions of binary outputs

- Selection or acknowledgment of paralleling point/parameter set
- Switchover contact that switches the command circuit in series with the manual paralleling switch in synchrocheck mode
- Signaling of the following variables:
 - Paralleling command in TEST mode
 - Dead bus released
 - Active STOP on the input
 - Phase-angle difference within tolerance band
 - Slip within tolerance band
 - Voltage difference within tolerance band
 - Paralleling command released
 - U1 leading or lagging
 - $f_2 > f_1$; $f_2 < f_1$
 - $U_2 > U_1$; $U_2 < U_1$
 - U1 or U2 outside of permissible range
 - Monitoring of the CMD contacts triggered
 - Single device operation (only SYN 6302)

Additional functions:

- Selection of 20 parameter sets
- Tap changer control

SYNCHROTECT 6

Dimension diagrams

SYN 6200
SYN 6201
SYN 6202

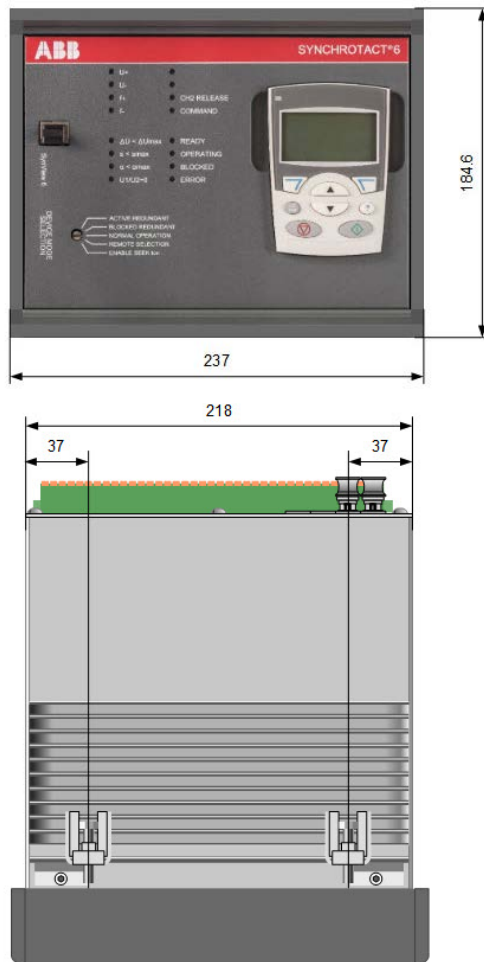

Panel cut-out W x H = 222 mm x 164 mm

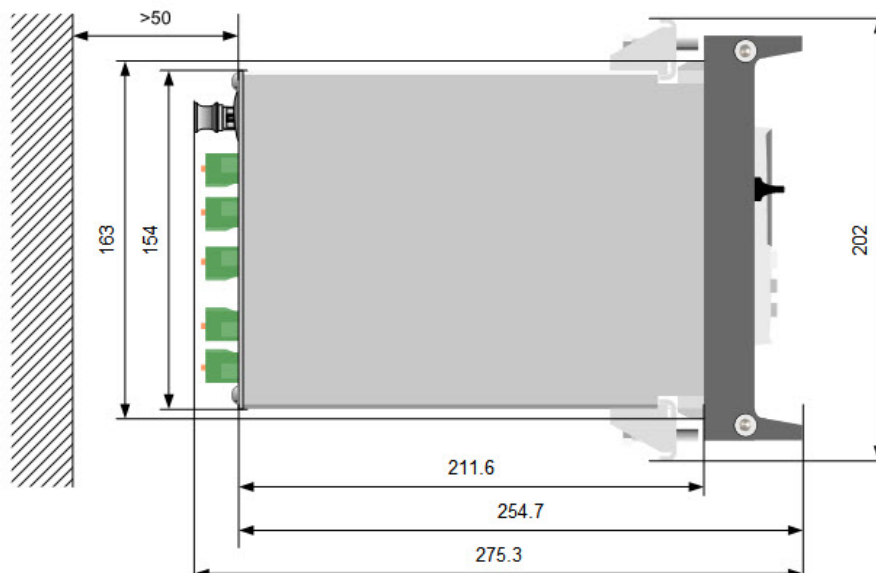

SYNCHROACT 6

Dimension diagrams

SYN 6302

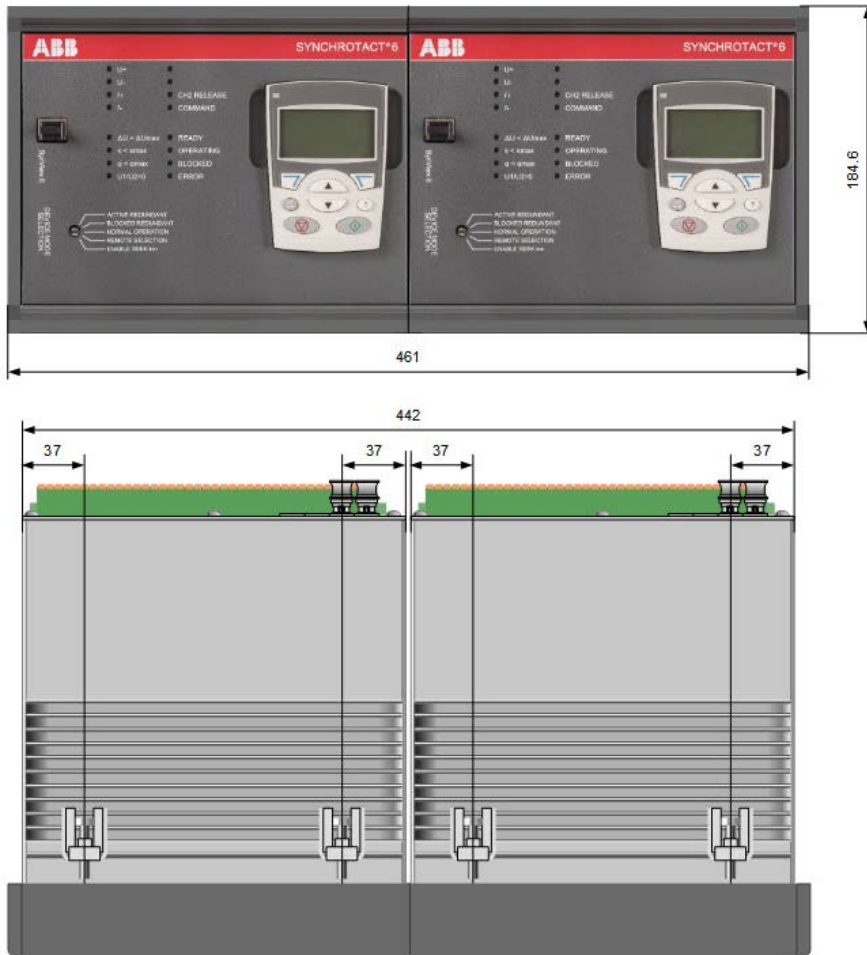

Panel cut-out W x H = 443 mm x 155 mm

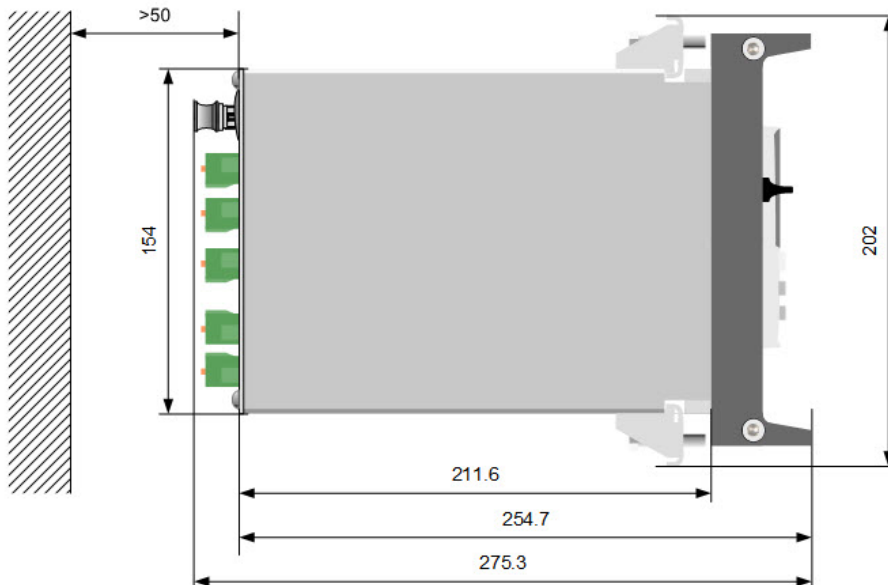

SYNCHROTACT 6

Technical data

Relevant standards

CE-conformity	
EMC directive	2014/30/EU
Related product standard	EN 60255-26
Low-voltage directive	2014/35/EU
Related product standard	EN 60255-27
Product standards	
Measuring relays and protection equipment	IEC 60255-1
EMC requirements for measuring relays and protection equipment	IEC60255-26
Safety requirements for measuring relays and protection equipment	IEC60255-27
Hydro Québec standard for electronic equipment and relays	SN-62.1008-1
IEEE standard for relays	IEEE C37.90-2005
Functional safety of E/E/PE safety-related systems	IEC 61508-series

Inputs

Auxiliary voltage	
Nominal voltage range	24 to 250 VDC 100 to 230 VAC
Permissible voltage range	19.2 to 300 VDC 75 to 300 VAC
SYN 620v Power consumption	READY 22 W/35 VA OPERATING 24 W/37 VA
SYN 6302 Power consumption	READY 2 x 22 W/35 VA OPERATING 2 x 24 W/37 VA
Measuring inputs U1, U2	
Nominal voltage range	50 to 130 VAC
Voltage range	0 to 130 %Un
Nominal frequency	16 ² / ₃ , 50, 60 Hz
Frequency range	10 to 100 Hz
Binary inputs	
Nominal voltages	24 to 125 VDC 100 to 125 VAC
Current consumption	≤ 2 mA

Construction data

Degree of protection in accordance with IEC 60529	
IP 50	
Dimensions	
SYN 6200, SYN 6201, SYN 6202	See dimension Diagrams
SYN 6302	Diagrams
Weight	
SYN 6200, SYN 6201, SYN 6202	7 kg net/10 kg gross
SYN 6302	14 kg net/22 kg gross

Outputs

Paralleling relays	
Maximum contact voltage	250 VAC/250 VDC
Limiting continuous current	10 A
Maximum switching power ON	3000 VA/3000 W
Maximum switching power OFF (resistive)	3000 VA/85 W
Adjusting command and signaling relays	
Maximum contact voltage	250 VAC/250 VDC
Limiting continuous current	4 AAC/4 ADC
Maximum switching power ON/OFF (resistive)	1000 VA/75 W

Interface

PC Tool 'SynView 6' Ethernet	
Bridgeable distance	100 m

SYNCHROACT 6

Technical data

Parameter setting ranges

Measurement	Step	Setting range
Nominal voltage	1 V	50 to 130 VAC
Voltage ratio (U1/U2)	0.01%	0.2 to 5%
Angle tuning	1 DEG	±180 DEG
Command generation		
Paralleling time	1 ms	1 to 999 ms
Duration of paralleling command	1 ms	50 to 999 ms
Monitoring times	1 s	0 to 99 s
Paralleling conditions		
Slip limit*	0.001%	0 to 6%
Angle limit (angle window)*	0.1 DEG	0 to 99.9 DEG
Maximum voltage difference*	0.1 %	0 to 40 %
Maximum voltage	1%	105 to 130 %
Minimum voltage	1%	50 to 95 %
Note: *Positive and negative limit values can be set separately		
Dead bus conditions		
Maximum zero voltage for dead bus	1%	0 to 49 %
Note: The following possibilities, and all combinations thereof, can be allowed or ruled out for paralleling by means of programming: U1 = dead bus; U2 = dead bus; both sides dead bus		
Voltage matcher		
Voltage adjustment characteristic	0.01 %/s	0 to 5 %/s
Interval between pulses	1 s	1 to 20 s
Minimum pulse duration	0.01 s	0.05 to 10 s
Note: The length of the adjusting pulse is proportional to the voltage difference. The proportionality factor (0.01 to 5 %/s) is adjustable. Alternatively, it is possible to work with fixed pulse length (0.05 to 10 s), in which case the interval times are inversely proportional to the voltage difference.		
Frequency matcher		
Frequency adjustment characteristic	0.01 %/s	0 to 5 %/s
Interval between pulses	1 s	1 to 120 s
Minimum pulse duration	0.01 s	0.05 to 10 s
Note: The length of the adjusting pulse is proportional to the slip. The proportionality factor (0.01 to 5 %/s) is adjustable. Alternatively, it is possible to work with fixed pulse length (0.05 to 10 s), in which case the interval times are inversely proportional to the slip.		
Time indications		
Lockout period after START	1 s	1 to 10 s
Total paralleling time abort after START/CMD	1 min/1 s	1 to 15 min/1 to 30 s

SYNCHROTECT 6

Technical data

Environmental values

Isolation			
Dielectric test		IEC 60255-27 (2013)	communication: 1 kV other: 2.5 kV
Impulse voltage test		IEC 60255-27 (2013)	communication: 1 kV other: 5 kV; 5+/5-; 1 s
Temperature range			
Transport/storage			-40 to +85 °C
Operation <16h			-40 to +85 °C
Operation (compliance with technical data)			-25 to +55 °C
Mechanical stability			
Vibration:			5 to 500 Hz
– Response and endurance		IEC 60255-21-1	7.5 mm; 20 m/s ²
Shocks and bumps:			class 2
– Shock response			10 g
– Withstand		IEC 60255-21-2	30 g
– Bump			20 g
Earthquake:			Method A; 5 to 35 Hz
– Single axis sine sweep seismic test		IEC 60255-21-3	7.5 mm; 50 m/s ²
Emission/immunity (EMC)			
Emission AC mains conducted disturbance	CISPR 22		Class B 0.15 to 0.5 MHz: 66 to 56 dB/56 to 46 dB 0.5 to 5 MHz: 56 dB/46 dB 5 to 30 MHz: 60 dB/50 dB
Emission, enclosure radiation disturbance	CISPR 11		Class A (3 m distance) 30 to 230 MHz: 50 dB 230 to 1000 MHz: 57 dB
	CISPR 22		Class A (3 m distance) 1 to 3 GHz: 56 dB/76 dB 3 to 6 GHz: 60 dB/80 dB
Electrostatic discharge	IEC 60255-26 IEC 61000-4-2 IEEE C37.90.3		Class 4 Contact: 8 kV Air: 15 kV
Electromagnetic fields	IEC 60255-26 IEC 61000-4-16		Frequency sweep: 15 Hz to 150 kHz: 30 V continuous Line frequency: continuous: 10 V; 1 s: 300 V (CM) and 150 V (DM)
	IEC 60255-26 IEC 61000-4-6		0.15 to 80 MHz: 20 V; 80 %AM
	IEC 60255-26 IEC 61000-4-3 IEEE C37.90.2		Frequency sweep: 80 to 1000 MHz: 20 V/m; 80 %AM 1.4 to 2.7 GHz: 20 V/m; 80 %AM
Fast transients	IEC 60255-26 IEC61000-4-4 IEEE C37.90.1 (fast transient)		4 kV
	IEC 61000-4-12		2.5 kV L-G and 1 kV L-L
Damped oscillatory wave	IEC 61000-4-18 IEEE C37.90.1 (oscillatory)		2.5 kV common and differential mode 1 MHz and 100 kHz
Surge voltage	IEC 60255-26 IEC 61000-4-5		Zone A L-G: 0.5/1/2/4 kV L-L: 0.5/1/2 kV
Voltage dips	IEC 60255-26		AC:
	IEC 61000-4-11		70 % Uresidual: 25 cycles
	IEC 61000-4-29		40 % Uresidual: 10 cycles 0 % Uresidual: 2.5 cycles & 250 cycles
			DC: 500 ms 200 ms 50 ms & 5 s

SYNCHROTECT 6

Spare parts

Spare parts

Designation	Type
Single device	SYN 6302-P

Recommendation

No individual parts are available for the SYNCHROTECT 6 devices. It is therefore recommended that an identical, pre-set replacement device is kept in stock.

In case of SYN 6302, one single device SYN 6302-P is recommended as spare part.



SYNCHROTECT 5

Synchronizing and paralleling devices

026–027	Device types
028	Functions, options and ordering details
029	Option details
030–031	Dimension diagrams
032–035	Technical data
036	Spare parts

SYNCHROTACT 5

Device types

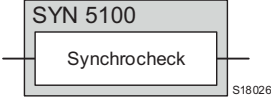
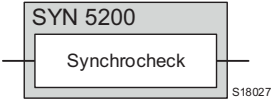
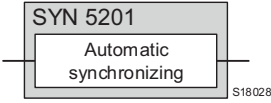
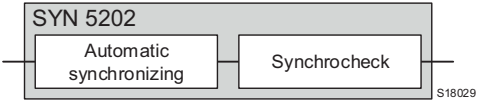
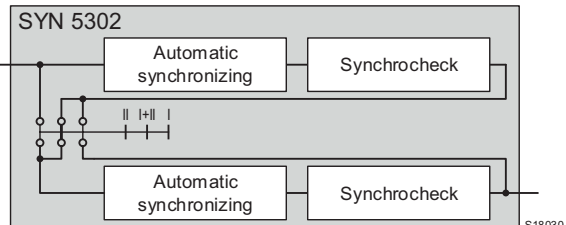
Type	Function	Symbol
SYN 5100		
	Synchrocheck	
SYN 5200		
	Synchrocheck or automatic paralleling unit without unit matcher	
SYN 5201		
	Automatic single-channel synchronizing device	
SYN 5202		
	Automatic dual-channel synchronizing device	
SYN 5302		
	Redundant automatic dual-channel synchronizing device	

Differences between SYN 5100 and SYN 5200

SYN 5100 offers a parameter set with five parameters. The auxiliary voltage range is 50 to 130 VAC or 100 to 125 VDC. SYN 5200 features communications interfaces, seven parameter sets, a wider auxiliary voltage range and the convenient PC tool SynView with all its functions. Additionally, because of its command generation, SYN 5200 can be used as an automatic paralleling unit.

Differences between SYN 5302 and SYN 5202

The SYN 5202 is a dual-channel system with two differently structured independent channels in the same casing. SYN 5302 consists of two SYN 5202 dual-channel devices in one casing. Both systems are normally all wired in series (four channels!). Should one system fail, it is possible to switch over, without danger, to the other dual-channel automatic system. This allows paralleling to be carried out fully automatically and with maximum security at all times. Additional costs for a redundant synchronizing system are saved.

Type Code

SYN 5 t 0v

Synchronizing mode

- 00: Synchrocheck
- 01: Single channel device
- 02: Dual channel device

Construction size

- 1: Small size
- 2: Medium size
- 3: Large size

SYNCHROTACT





- SYN: SYNCHROTACT
- 5: Fifth generation

S18035

SYNCHROTACT 5

Functions, options and ordering details

Functions at a glance

Function	Type				
Product					
	SYN 5100	SYN 5200	SYN 5201	SYN 5202	SYN 5302
Automatic synchronizing	No	Yes	Yes	Yes	Yes
Paralleling of two lines	Yes	Yes	Yes	Yes	Yes
Synchrocheck mode	Yes	Yes	Yes	Yes	Yes
Voltage matching	No	No	Yes	Yes	Yes
Frequency matching	No	No	Yes	Yes	Yes
Dual-channel system	No	No	No	Yes	Yes
Integrated, redundant system (bypass)	No	No	No	No	Yes
Number of parameter sets	1	either 1 or 7	either 1 or 7	either 1 or 7	either 1 or 7
Paralleling of synchronous lines	Yes	Yes	Yes	Yes	Yes
Paralleling of asynchronous lines	Yes	Yes	Yes	Yes	Yes
Paralleling of voltage-free lines	Yes	Yes	Yes	Yes	Yes
Signaling	No	Yes	Yes	Yes	Yes
Parameter setting by PC Tool SynView	No	Yes	Yes	Yes	Yes
Parameter setting without PC	Yes	Yes	Yes	Yes	Yes
Semi-flush mounting	No	Yes	Yes	Yes	Yes
Surface mounting	No	on request	on request	on request	on request
Top-hat rail mounting (DIN)	Yes	No	No	No	No

Options

Option	SYN 5100	SYN 5200, SYN 5201, SYN 5202, SYN 5302
w Communication	0: none	0: none 2: Modbus 3: Profibus 4: Lon-Bus 5: IEC 61850
x Code for internal use	2: internal code	2: internal code
y Auxiliary voltage/nominal frequency	Un = 50 to 130 VAC and 100 to 125 VDC 2: fn = 50/60 Hz 5: fn = 16 2/3 Hz	Un = 100 to 230 VAC and 24 to 250 VDC: 7: fn = 50/60 Hz 8: fn = 16 2/3 Hz
z Parameter sets	1: 1 parameter set	1: 1 parameter set 7: 7 parameter sets

Device type	Options
SYN 5u0v	- wxyz

Ordering details

Examples

SYN 5100 – 0221	Synchrocheck with nominal frequency 50 or 60 Hz and one parameter set
SYN 5200 – 0271	Synchrocheck with nominal frequency 50 or 60 Hz and one parameter set
SYN 5201 – 0287	Automatic single-channel synchronizing device with nominal frequency 16 2/3 Hz and seven parameter sets
SYN 5202 – 2277	Automatic dual-channel synchronizing device with communication (Modbus), nominal frequency 50 or 60 Hz and seven parameter sets
SYN 5302 – 5277	Redundant automatic dual-channel synchronizing device with communication (IEC 61850), nominal frequency 50 or 60 Hz and seven parameter sets

SYNCHROTACT 5

Option details

Option w: Communication interface

Characteristics of the field bus protocols	
Supported protocols	Modbus RTU; Profibus; LON
Interface type	Modbus and Profibus: RS 485 LON: Optical
Connector type	Modbus and Profibus: D-Sub9 (female) LON: HP BFOC/2.5 (optical)
Transmitted signals	Binary inputs/outputs; status indicators (LEDs); actual values (analog); new event
Addressing	Slave address, depending on fieldbus

Characteristics of the IEC 61850 interface	
Interface type	Ethernet
Connector type	RJ45
Transmitted signals	Binary I/Os (status information/controls); actual values (measured values)

SYN 5302:

The interfaces are duplicated, ie, each system can be

controlled individually. Commands, eg starting synchronizing, have to be given separately for each system.

Option z: Parameter sets

SYNCHROTACT 5 – devices with seven parameter sets include additional hardware with seven binary inputs and seven relay outputs. They are normally used for the selection

of both parameter set and paralleling point. The inputs and outputs that are not used can be configured for other functions. The possible functions are shown in the table below.

Configurable functions for devices with the "7 parameter sets" option

Configurable functions of binary inputs
Selection of parameter set or paralleling point
Selection of TEST mode
Starting, stopping and blocking of synchronizing process
Device Reset
Configurable functions of binary outputs
Selection or acknowledgment of paralleling point/parameter set
Switchover contact for the command circuit which must be connected in series with the manual paralleling circuit in synchrocheck mode
Signaling of the following variables:
– Paralleling command in TEST mode
– Dead bus released
– Synchronizing process stopped
– Phase-angle difference within tolerance band
– Slip within tolerance band
– Voltage difference within tolerance band
– Paralleling command released
– U1 leading or lagging
– $f_2 > f_1$; $f_2 < f_1$
– $U_2 > U_1$; $U_2 < U_1$
– U1 or U2 outside of permissible range
– Monitoring of paralleling contacts that have tripped
– Single-system operation (only SYN 5302)

SYNCHROTECT 5

Dimension diagrams

SYN 5100

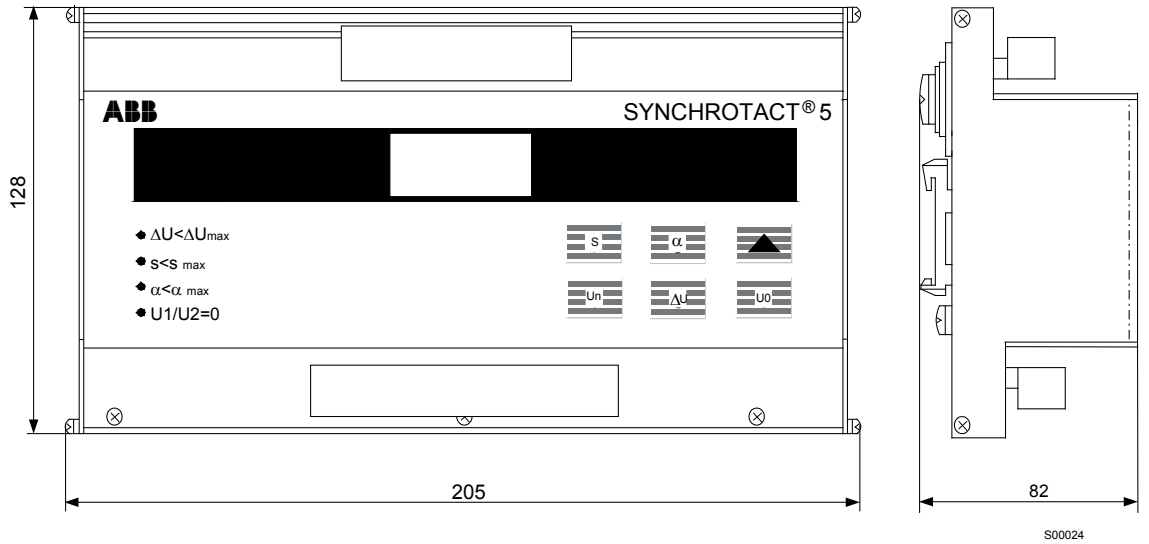

SYN 5200
SYN 5201
SYN 5202

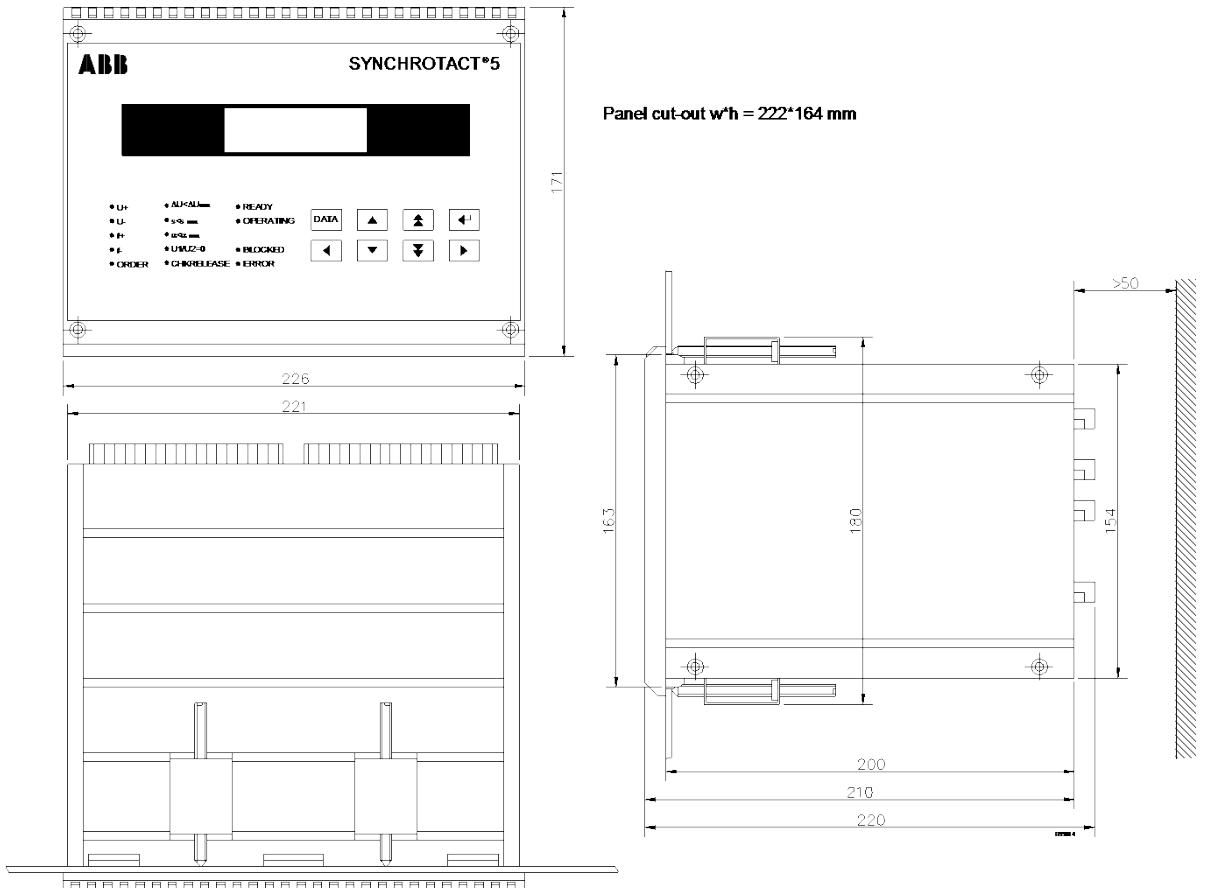

SYNCHROTACT 5

Technical data

Inputs

Auxiliary voltage		
Nominal voltage range		24 to 250 VDC 100 to 230 VAC
Permissible voltage range		18 to 300 VDC 75 to 300 VAC
SYN 520v		
Power consumption	READY OPERATING	12W/18 VA 12 W/18 VA
SYN 5302		
Power consumption	READY OPERATING	25 W/35 VA 25 W/35 VA
SYN 5100		
Maximum power consumption		2 W/4 VA
Measuring inputs U1, U2		
Nominal voltage range		50 to 130 VAC
Voltage range		0 to 130 %Un
Nominal frequency		16 ² / ₃ , 50, 60 Hz
Frequency range		10 to 100 Hz
Digital inputs		
Nominal voltages		24 to 48 VDC
Current consumption		6 to 8 mA

Outputs

Paralleling relays	
Maximum contact voltage	250 VAC/250 VDC
Limiting continuous current	10 A
Maximum switching power ON	1500 VA/1500 W
Maximum switching power OFF (resistive)	1500 VA/150 W
Adjusting command and signaling relays	
Maximum contact voltage	250 VAC/250 VDC
Limiting continuous current	1.5 AAC/1.5 ADC
Maximum switching power ON/OFF	50 VA/50 W

Interface

PC Tool 'SynView' Ethernet	
Bridgeable distance	100 m

SYNCHROACT 5

Technical data

Parameter setting ranges

SYN 5200, SYN 5201, SYN 5202 (channel 1), SYN 5302 (both channels 1)	Step	Setting range
Actual value calibration		
Nominal voltage	1 V	50 to 130 VAC
Voltage matching (between U1 and U2)	0.01%	±12%
Angle matching (SYN 5200 and SYN 5201 only)	1 DEG	±180 DEG
Command generation		
Paralleling time	10 ms	1 to 990 ms
Duration of paralleling command	10 ms	50 to 990 ms
Monitoring times	1 s	0 to 99 s
Paralleling conditions		
Slip limit*	0.01%	0 to 6%
Angle limit (angle window)*	1 DEG	1 to 99 DEG
Maximum voltage difference*	1%	0 to 40%
Maximum voltage	1%	100 to 130%
Minimum voltage	1%	50 to 95%
Note: *Positive and negative limit values can be set separately		
Dead bus conditions		
Maximum zero voltage for dead bus	1%	0 to 49%
Note: The following possibilities – and all combinations thereof – can be allowed or ruled out for paralleling by means of programming: U1 = dead bus; U2 = dead bus; both sides dead bus		
Voltage matcher		
Voltage adjustment characteristic	0.01 %/s	0 to 5 %/s
Interval between pulses	1 s	1 to 20 s
Minimum pulse duration	0.01 s	0.05 to 2 s
Note: The length of the adjusting pulse is proportional to the voltage difference. The proportionality factor (0.01 to 5 %/s) is adjustable. Alternatively, it is possible to work with fixed pulse length (0.05 to 2 s), in which case the interval times are inversely proportional to the voltage difference.		
Frequency matcher		
Frequency adjustment characteristic	0.01 %/s	0 to 5 %/s
Interval between pulses	1 s	1 to 120 s
Minimum pulse duration	0.01 s	0.05 to 2 s
Note: The length of the adjusting pulse is proportional to the slip. The proportionality factor (0.01 to 5 %/s) is adjustable. Alternatively, it is possible to work with fixed pulse length (0.05 to 2 s), in which case the interval times are inversely proportional to the slip.		
General parameters		
Blocking time following start signal	1 s	1 to 10 s
Total paralleling time	0.5 min	0.5 to 15 min; OFF

SYN 5100, SYN 5202 (channel 2), SYN 5302 (both channels 2)	Step	Setting range
Slip limit	0.1%	0.1 to 2%
Angle limit	5 DEG	5 to 40 DEG
Maximum voltage difference	5%	5 to 40%
Maximum zero voltage for dead bus	5%	0 to 50%
Nominal voltage	5 V	50 to 130 VAC
Note: The percentages refer to the nominal values		

SYNCHROTECT 5

Technical data

Environmental values

Isolation		
Dielectric test	IEC 60255-5	2 kV
Impulse voltage test	IEC 60255-5	5 kV
Temperature ranges for devices without communication		
Transport/storage		-40 to +85 °C
Functionable		-25 to +70 °C
Operation (compliance with technical data)		-10 to +55 °C
Temperature ranges for devices with communication		
Transport/storage		-10 to +85 °C
Functionable		+5 to +70 °C
Operation (compliance with technical data)		+5 to +55 °C
Mechanical stability		
Vibration:		10 to 150 Hz; cl. 2
– Response	IEC 60255-21-1	1 g
– Endurance		2 g
Shocks and bumps:		class 2
– Shock response		10 g
– Withstand	IEC 60255-21-2	30 g
– Bump		20 g
Earthquake:	IEC 60255-21-3	Method A
– Single axis sine sweep seismic test	IEEE STD 344-1987	5 g in each axis
Emission/immunity (EMC)		
Emission AC mains conducted disturbance	CISPR 22	Class B 0.15 to 0.5 MHz: 66 to 56 dB/56 to 46 dB 0.5 to 5 MHz: 56 to 46 dB 5 to 30 MHz: 60 dB/50 dB
Emission, enclosure radiation disturbance	CISPR 11	Class A 30 to 230 MHz: 30 dB 230 to 1000 MHz: 37 dB
Electrostatic discharges	IEC 60255-22-2 IEC 61000-4-2 IEEE C37.90.3-2001	Class IV Contact: 8 kV Air: 15 kV
	IEC 61000-4-16	0 to 150 kHz: 30 V continuous; 300 V for 1 s
	IEC 61000-4-6	0.15 to 80 MHz 10 V; 80 %AM
Electromagnetic fields	IEC 60255-22-3 IEC 61000-4-3	Frequency sweep: 80 to 1000 MHz: 10 V/m; 80 %AM 1.4...2 GHz: 20 V/m; 80 %AM Spot frequencies: 80/160/450/900 MHz: 80 %AM; Testing time >10 s
	IEEE C37.90.2-2004	25 to 1000 MHz: 20 V/m; 80 %AM (max. result. field strength: ≥35 V/m)
	IEC 60255-22-4 IEC61000-4-4	Class IV; 4 kV
Fast transients	IEEE C37.90.1-2002 ("fast transient SWC test")	4 kV common and transverse mode
	IEC 61000-4-12	2.5 kV
Surge voltages	IEC 61000-4-5	Installation classification: class 3 ±1/±2 kV
Voltage dips	IEC 61000-4-11	AC: 30%: 10 ms 60%: 100 ms >95%: 5000 ms
1 MHz burst disturbance	IEC 60255-22-1	Class III 2.5 kV common and transverse
	IEEE C37.90.1-2002 ("oscillatory SWC test")	2.5 kV common and transverse

SYNCHROACT 5

Technical data

Relevant standards

CE-conformity		
EMC directive	2014/30/EU	
Generic standard	EN 61000-6-4 EN 61000-6-2	Emission Immunity
Low-voltage directive	2014/35/EU	
Safety of information technology equipment	EN 60950	
Product standards		
Measuring relays and protection equipment	IEC 60255-6	
Product standard for measuring relays and protection equipment	EN 50263	
Hydro Québec standard for electronic equipment and relays	SN-62.1008d	
IEEE standard for relays	IEEE C37.90-1989	

Construction data

Degrees of protection in accordance with IEC 60529	
Front	IP 54
Rear	IP 50
Dimensions	
SYN 5100	
Top-hat rail mounting (DIN)	See illustration of dimensions
SYN 5200, SYN 5201, SYN 5202	
SYN 5302	
Weight	
SYN 5100	0.3 kg
SYN 5200, SYN 5201, SYN 5202	4 kg
SYN 5302	8 kg

SYNCHROTACT 5

Spare parts

Spare parts

PCB designation	Type
Communications board IEC 61850	SYN 5009
Communications board	SYN 5010
Processor and power supply board (Indication of device type required, eg, SYN 5201)	SYN 5011
Basic I/O unit	SYN 5012
Processor for channel 2 (synchrocheck)	SYN 5013
Extended I/O/seven parameter sets (option)	SYN 5014
Bus board for SYN 520x	SYN 5015
System control	SYN 5020
Bus board for SYN 5302	SYN 5025

Ordering information

When ordering, please state the complete type designation of the synchronizing unit.

Recommendation

No individual parts are available for the SYN 5100 unit. It is therefore recommended that an identical, pre-set replacement unit is kept in stock.

In the case of SYN 520x units, it is recommended that an identical, pre-set replacement unit is kept in stock.

In the case of the SYN 5302, the following PCB modules are recommended as spare parts: SYN 5020 system control and SYN 5014 extended I/O card, if the latter is installed.



SYNCHROTACT Datasheet

Index

SYNCHROTACT 6

SYNCHROTACT 5

SYNCHROTACT
ACCESSORIES

SYNCHROTACT
SYNCHRONIZING
SYSTEMS

SYNCHROTACT
SERVICE AND SUPPORT

1

2

3

4

5

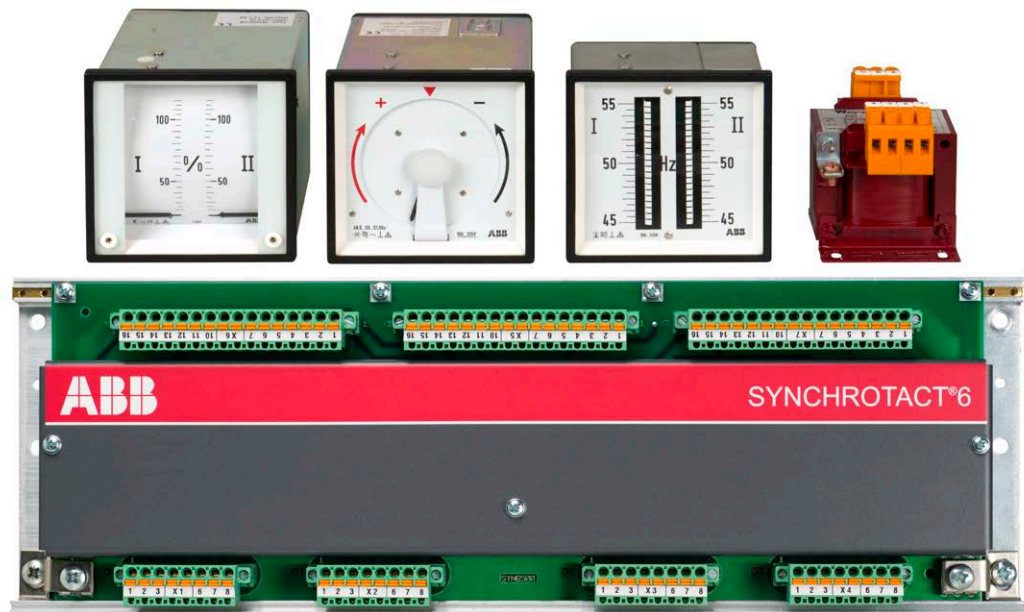

SYNCHROTACT

Accessories

SYNCHROTACT 6 Accessories

- 041** Fast commissioning with SynView 6
- 042** Auxiliary device SYN 6500

SYNCHROTACT 5 Accessories

- 043** SynView and SYN 5500

SYNCHROTACT Accessories

- 044–045** Synchronizing instruments
- 046–047** Adaptation and compensation voltage transformers



SYNCHROTACT 6 Accessories

Fast commissioning with SynView 6

SynView 6 is a tool for simple and fast commissioning of SYNCHROTACT 6 devices. The PC software runs under MS® Windows™ 7 and 10 in the standard languages German and English. SynView 6 consists of the following modules:

Actual values module

A synchroscope, together with all the values which are important for paralleling, is displayed on the user interface. This simplifies function-testing and tracking of the synchronizing process.

Parameter module

All parameter settings are carried out using this tool. The files can be stored on the PC and copied to other units. Helpful functions such as comparing parameter settings between device and PC-file, or the display of recommended setting values, greatly simplify commissioning and servicing.

Events module

The 2000 events stored in SYNCHROTACT 6 are displayed in plain text with a date and time stamp. This greatly simplifies the localization of faults, eg, wiring or control faults which sometimes occur during commissioning.

Transient recorder module

Two transient recorders are configured in the SYNCHROTACT 6 ex works. They automatically record and store the data that is important for synchronization. Thus, SynView 6 can be used to graphically display the data of several hundred synchronization processes.

Options module

This module contains SynView 6-specific settings as well as SYNCHROTACT 6 settings (IP address handling, IEC 61850 settings etc.)

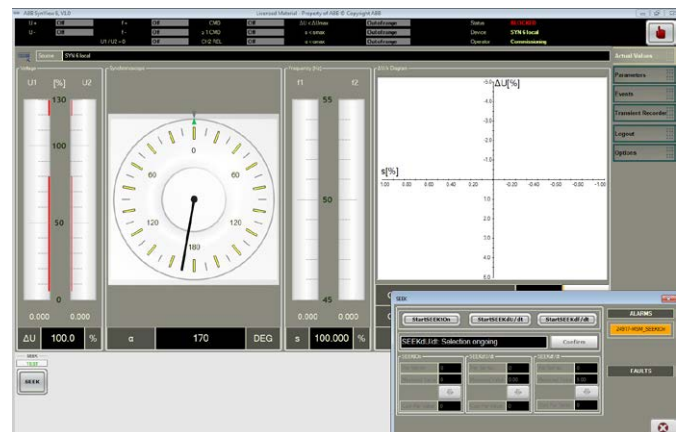
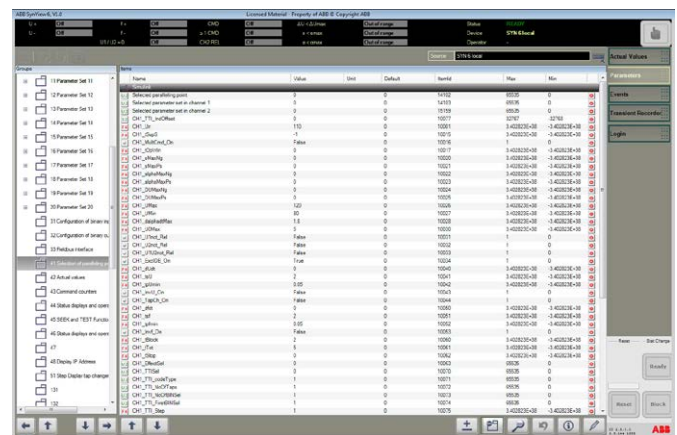

SYNCHROTECT 6 Accessories

Auxiliary device SYN 6500

The auxiliary device SYN 6500 connects the measuring and command circuits where several paralleling points need to be switched. A SYN 6500 device can switch two paralleling points, each with a maximum of 16 contact pairs, or alternatively four paralleling points, each with eight contact pairs. Several devices can be used at the same time.

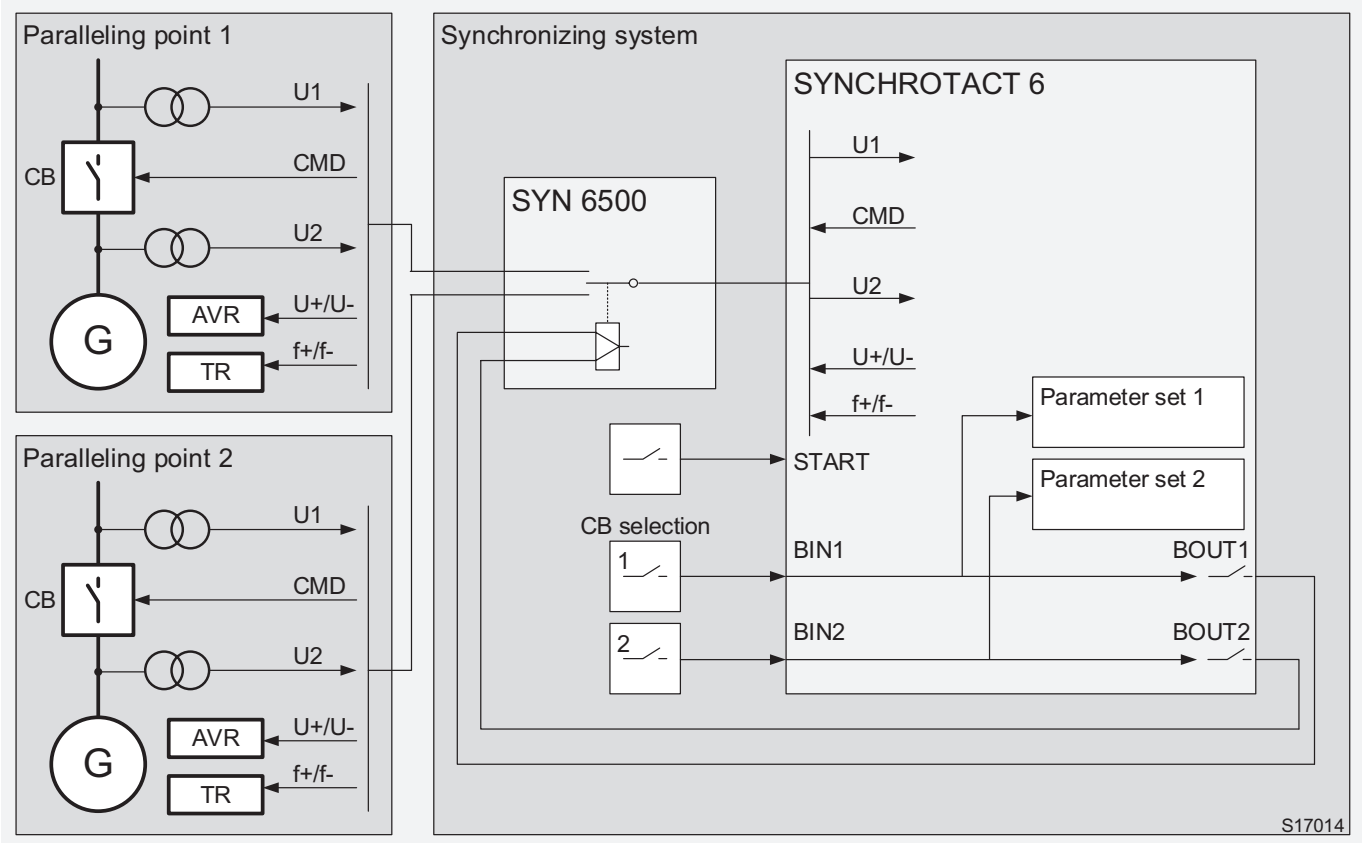

Ordering details

Designation	Type	Part no
Auxiliary device for switching several paralleling points	SYN 6500	3BHE 056 500 R0001

Technical data

Maximum contact voltage	250 VAC/250 VDC
Limiting continuous current	10 A
Maximum switching power ON	1500 VA/1500 W
Maximum switching power OFF (resistive)	1500 VA/150 W
Coil nominal voltage	24 VDC
Operate voltage	≥ 18 VDC
Release voltage	≤ 3.6 VDC
Coil resistance	1152 Ω
Coil inductivity	1000 mH
Casing size (W x H x D)	381 x 128 x 50 mm
Top-hat rail mounting (DIN)	

SYNCHROACT 5 Accessories

SynView and SYN 5500

SynView is a tool for simple and fast commissioning of SYNCHROACT 5 devices. The PC software runs under MS® Windows™ NT, 95, 98, 2000, XP and Windows 7 in the standard languages German, English or French. SynView consists of the following five tools:

- **Parameter tool**
- **Transient recorder tool**
- **Actual values tool**
- **Event recorder tool**
- **Diagnostic tool**

SynView ordering details

Designation	Type	Part no
PC-Tool for commissioning and maintenance	SynView	–
– with Ethernet cable	RJ45	3BHE 021 768 R0002
– with RS232 cable	D-Sub9	3BHE 021 768 R0001

The auxiliary device SYN 5500 is technically compliant with the SYN 6500. The latter has been adapted to the SYNCHROACT 6 design:

SYN 5500 ordering details

Designation	Type	Part no
Auxiliary device for switching several paralleling points	SYN 5500	3BHB 006 500 R0001

SYNCHROTACT Accessories

Synchronizing instruments

Electromechanical instruments are commonly used if the synchronizing system provides a manual synchronizing feature.

Options

Designation		
Option		Code
w	Nominal voltage	1 100/ $\sqrt{3}$ = 57.7 V
		2 110/ $\sqrt{3}$ = 63.5 V
		3 115/ $\sqrt{3}$ = 66.4 V
		4 120/ $\sqrt{3}$ = 69.3 V
		5 100 V
		6 110 V
		7 115 V
		8 120 V
x	Nominal frequency	5 50 Hz
		6 60 Hz
y	Labeling	1 Standard labeling
		2 Labeling according to separate specification
z	Size	0 96 x 96 mm
		1 144 x 144 mm

Ordering details

Designation	Type	Part no
Double volt meter	SYN 5U96-wxy0 SYN 5U144-wxy1	3BHE022 313Rwxy0 3BHE022 313Rwxy1
Double frequency meter	SYN 5F96-wxy0 SYN 5F144-wxy1	3BHE022 314Rwxy0 3BHE022 314Rwxy1
Synchroscope	SYN 5S96-wxy0 SYN 5S144-wxy1	3BHE022 315Rwxy0 3BHE022 315Rwxy1

General technical data

Isolation	IEC 60255-5	2 kV
Temperature range	Operation	-25 °C to +40 °C
	Storage	-25 °C to +65 °C
Relative humidity		≤75 % annual average, no condensation
Shock		15 g, 11 ms
Vibration		2.5 g, 5 to 55 Hz
Protection degree	- casing	IP 54
	- connections	IP 00
Dimensions width x height x installation depth	Size 96	96x96x115 mm
	Size 144	144x144x164 mm
Front frame	96/144	96 mm/144 mm
Casing	96/144	90 mm/136 mm
Panel cut-out	96/144	92 ^{+0.8} mm/138 ⁺¹ mm
Fixing		Screw clamps
Electrical connection		Screw-type terminals

SYNCHROTECT Accessories

Synchronizing instruments

General Technical data		
Fixing		Screw clamps
Electrical connections		Screw-type terminals
Technical data double volt meter		
Measuring range voltage		0 to 120 %Un
Scale arrangement		vertical
Power consumption per input	with $U_n \leq 110\text{ V}$	96: $2 \times <2\text{ VA}$ /144: $2 \times <2.3\text{ VA}$
Accuracy		Class 1.5
Weight	96/144	1.2 kg/1.5 kg
Technical data double frequency meter		
Measuring range frequency		$f_n \pm 5\text{ Hz}$
Number of reeds		2×21
Measuring range voltage		0 to 120 %Un
Scale arrangement		vertical
Power consumption per input	with $U_n \leq 110\text{ V}$	$2 \times <1.1\text{ VA}$
Accuracy		Class 0.5
Weight	96/144	0.65 kg/1 kg
Technical data synchroscope		
Voltage range		$0.9 \times U_n$ to $1.1 \times U_n$
Overload limit		$1.2 \times U_n$
Power consumption per input	with $U_n \leq 110\text{ V}$	$<4.0\text{ VA}$ (line side) $<0.7\text{ VA}$ (generator side)
Weight	96/144	1.0 kg/1.8 kg

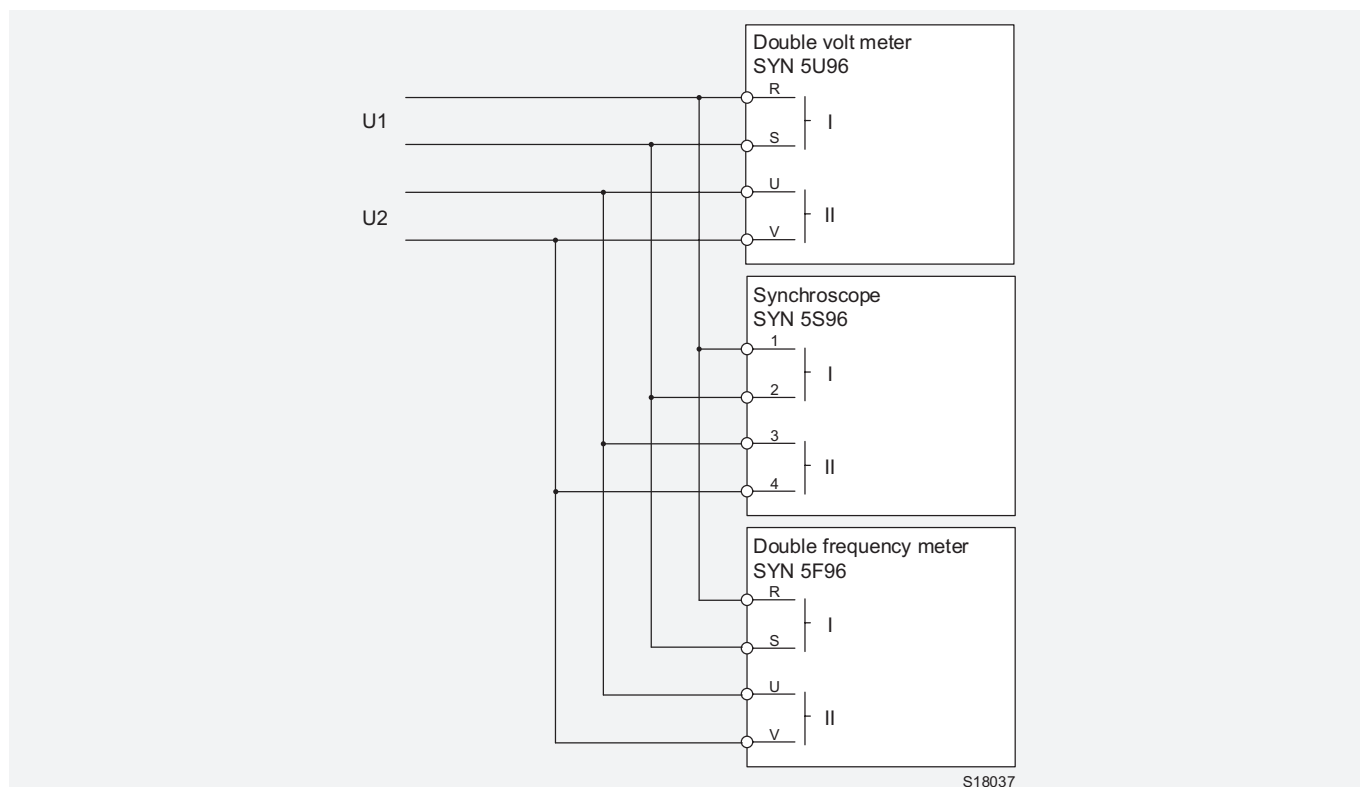

Connection diagram synchronizing instruments

SYNCHRO TACT Accessories

Adaptation and compensation voltage transformers (VTs)

When are adaptation or compensation VTs needed?

- If both nominal measuring voltages are out of admissible range (50 to 130 VAC).
- If the nominal amplitude values of both measuring voltages are different and if components are used which cannot compensate for this difference electronically.

- If both of the following conditions are valid:
 - Phase-difference angle is shifted by a fixed value, eg, a step-up transformer between measuring VT and circuit breaker
 - Components are used which cannot compensate for this difference electronically

Hints to select compensation VTs

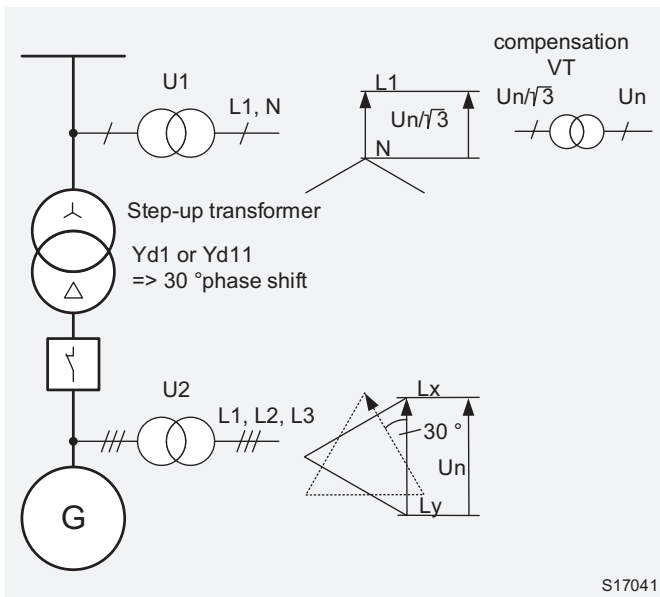

Phase-angle compensation with compensation VT

If possible, the compensation should be done in a way that a single-phase compensation VT is required only If there is a step-up transformer between measuring VT and circuit breaker, the connection group is usually Yd1 (+30 DEG) or Yd11 (-30 DEG).

With the appropriate selection of the phases, the phase shift can be compensated without any additional components. In this example the compensation of the amplitude by factor $\sqrt{3}$ remains. This can be done by a single-phase compensation VT.

In order to achieve higher accuracy, especially if higher load (synchronizing instruments) is connected, the compensation should be carried out on the generator side.

If a three-phase compensation is inevitable, 3 single-phase VTs have to be selected which will then be connected according to the needs. Be aware that the single-phase ratio has to be calculated.

SYNCHROACT Accessories

Adaptation and compensation voltage transformers (VTs)

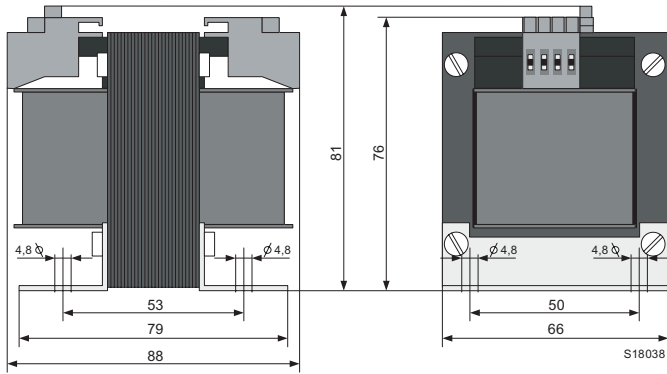

Dimensional drawing

Ordering details

Designation	Type	Part no
Single phase VT	SYN 5T66-0001	3BHE024 870R0001

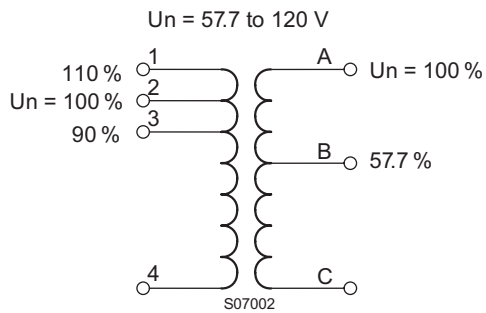

Connection diagram

Examples

Example	Ratio	Connection
100 V → 100 V 110 V → 110 V 120 V → 120 V 63.5 V → 63.5 V 57.7 V → 57.7 V	1	2-4 A-C
110 V → 100 V	0.909	1-4 A-C
100 V → 57.7 V 110 V → 63.5 V 120 V → 69.3 V	$1/\sqrt{3} = 0.577$	2-4 B-C
100 V → 63.5 V	$1.1/\sqrt{3} = 0.635$	3-4 B-C
110 V → 57.7 V	$1/(1.1 \times \sqrt{3}) = 0.525$	1-4 B-C

Example	Ratio	Connection
100 V → 110 V	1.1	A-C 1-4
57.7 V → 100 V 63.5 V → 110 V 69.3 V → 120 V	$\sqrt{3} = 1.73$	B-C 2-4
63.5 V → 100 V	$\sqrt{3}/1.1 = 1.57$	B-C 3-4
57.7 V → 110 V	$1.1 \times \sqrt{3} = 1.91$	B-C 1-4

Technical data

Nominal voltage range primary and secondary	57.7 to 120 VAC	
Accuracy/power without synchronizing instruments	Class 1/0.05 VA	
Accuracy/power with synchronizing instruments	Class 2/4 VA	Class 5/7.5 VA
Dimensions (WxHxD)	66x81x88 mm	
Weight	1.0 kg	

4



SYNCHROTACT Synchronizing systems

Project-specific synchronizing systems

050 **Application**

051 **Typical requirement characteristics of a synchronizing system**

SYNCHROTACT Synchronizing systems

Application

SYNCHROTACT synchronizing cabinets can be designed specifically for customer requirements and are used to synchronize generators and to parallel lines. Depending on available space, other systems may be used in the same cabinet. This might be eg, measuring and metering functions.

Example: Synchronizing cabinet with local control and 2 counters

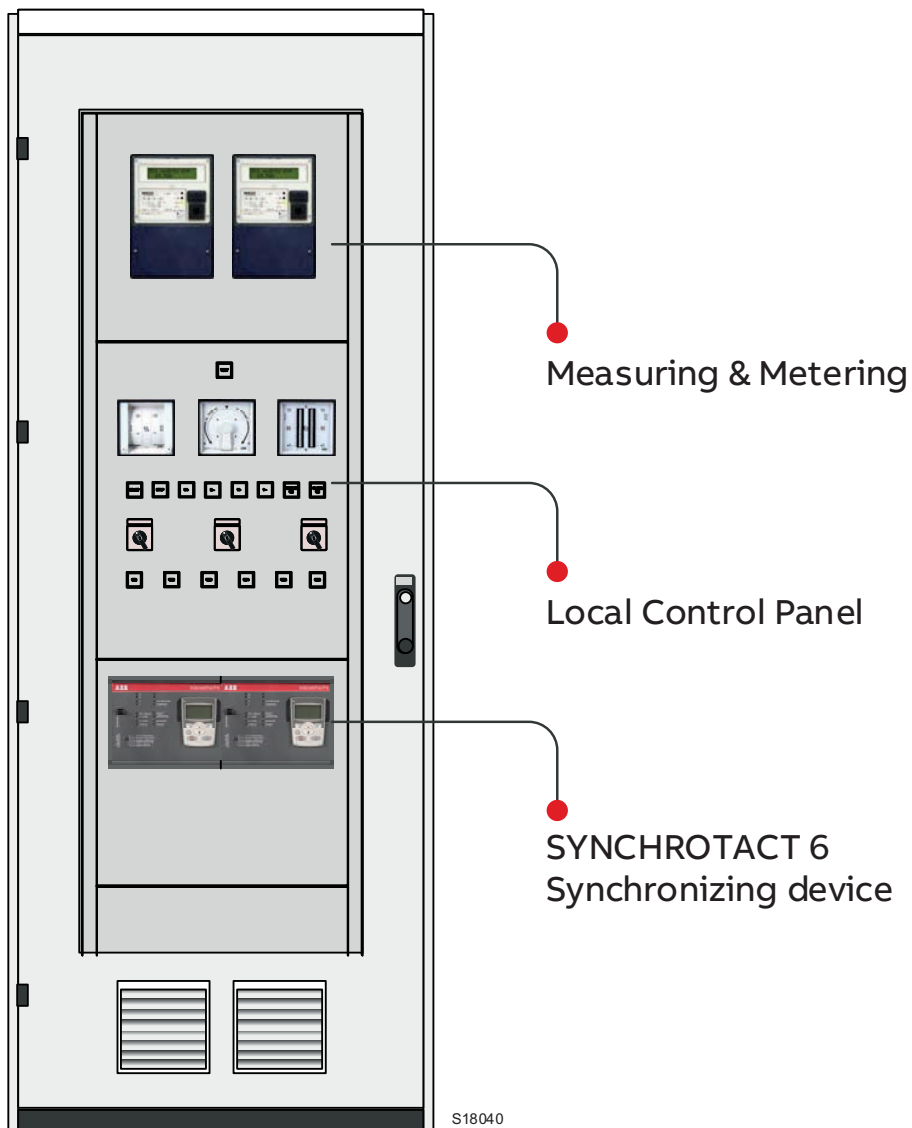

S18040

SYNCHROTACT Synchronizing systems

Typical requirement characteristics of a synchronizing system

The system uses proven SYNCHROTACT 6 – components and may be individually adapted. Typical characteristics are as follows:

1. Safety: Single- or dual-channel solutions
2. Availability: Redundant manual synchronizing or redundant automatic synchronizing or both
3. Number of circuit breakers to be synchronized
4. Power supply: In case of redundant synchronizing, the power supply on the cubicle entrance can be redundant too.
5. Synchronizing control: Remote, local or both
6. Adaptation of the measuring voltages: Especially with synchronizing of several circuit breakers, it may occur that the two secondary voltages have different amplitudes and phase angles with closed circuit breaker.

Examples of synchronizing concepts

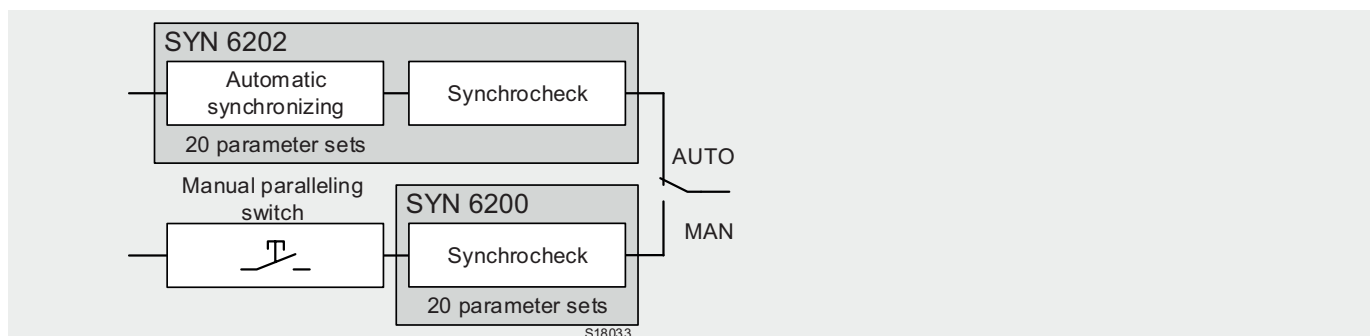

Automatic dual-channel synchronizing system with redundant manual synchronizing

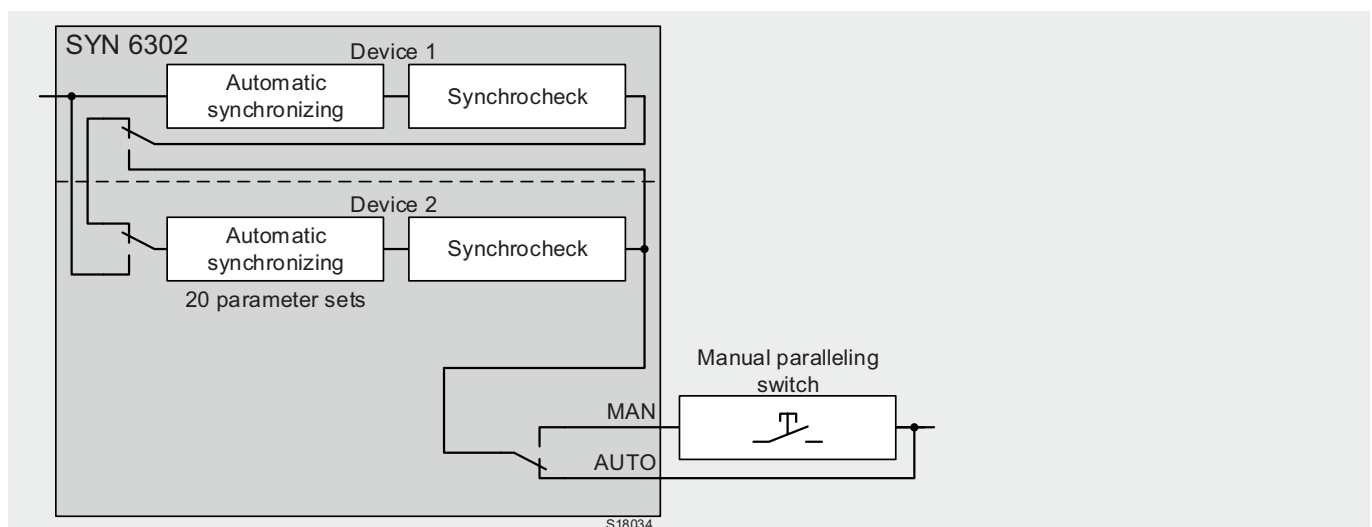

Redundant, automatic dual-channel synchronizing system and additional manual synchronizing possibility



5



SYNCHROTRACT

Service and support

054–055 **Service and support**

SYNCHROTACT

Service and support

ABB, your expert for all services on SYNCHROTACT synchronizing equipment. As your service partner ABB ensures comprehensive support for the product range of our synchronizing equipment and excitation systems over the entire lifecycle.

Installation and commissioning

ABB Services – reliable, fast and customer-oriented.

Our global service network with more than 100 experienced and trained engineers worldwide are the key element for the smooth and fast commissioning as well as for correct setting of the synchronizer. A professional project documentation enables best possible support in the long term.

Key benefits

- Availability of competent professionals on short notice
- Increased availability and safety of the plant

Service Agreement – ABB Excitation Care

Increased efficiency and controlled costs, focusing on the core business.

The ABB Excitation Care – Service Agreement covers not only our excitation systems but also our synchronizing equipment. In addition to customer telephone support, 24/7-emergency support and periodic maintenance. ABB additionally offers guaranteed response times and on-site troubleshooting.

Key benefits

- Support by certified and experienced engineers
- 24/7-telephone support, 365 days a year
- Minimizing the outage risk

Training

Your knowledge is your future – the mission of ABB University for Power Electronics.

ABB offers outstanding expertise for maintenance and operating personnel. The SYNCHROTACT courses deepen the basic knowledge in synchronization, provide product expertise and enable the participants to work on the synchronization equipment independently and confidently.

Key benefits

- Trained personnel reduces downtime of the plant
- Increased workplace safety through improved knowledge of the users

SYNCHROTACT

Service and support

Product Life Cycle Management

Full service and support

Our life cycle approach is based on the four-phase model shown below. By means of proactive communication, the customer will be informed by an official "Life Cycle transfer notice" before the product enters a critical phase. So that necessary measures for a seamless operation of the plant can be taken in time. (*)

Key benefits

- Higher operating reliability
- Reduced life cycle costs

Spare Parts Management

Maintaining a reliable spare parts stock.

All electronic components suffer degradation over time. The same applies to components for synchronizing systems. This concerns the installed systems and the components in the spare parts stock. ABB provides a service for original spare parts and a review of spare parts at the customer's stock.

Key benefits

- Ensuring the reliability of spare parts
- Availability of spare parts at the lowest cost

Repairs

Fast and easy product support

If one unit fails, it can be quickly and easily sent back for inspection and repair at the ABB Return Center.

Key benefits

- Simple return process
- Troubleshooting at ABB manufacturing site

Replacement solutions

Migration to the latest product, or replacement of the entire synchronizing?

As a leader in synchronizing business, ABB offers the expertise and experience of alternative solutions for synchronizing equipment, regardless of manufacturer.

The replacement of an old synchronizing device by one of the active life-cycle phase is a time- and cost-efficient solution. When a complete synchronization must be replaced, ABB offers its customers a tailor-made solution.

Key benefits

- Improved system availability through reduced downtime
- Seamless operation of the plant

ABB Life cycle model (*)





ABB Switzerland Ltd

Synchronizing Equipment
and Excitation Systems

Austrasse

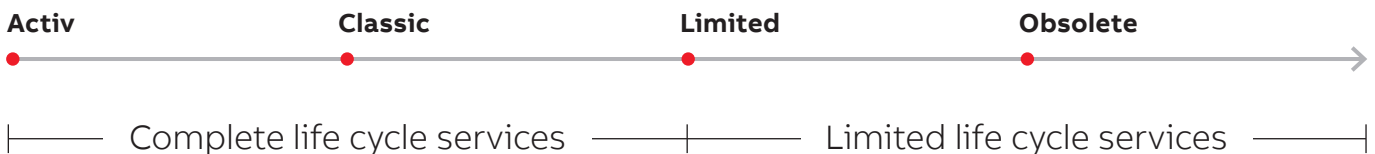
CH-5300 Turgi, Switzerland

Phone: +41 (0)58 589 24 86

Fax: +41 (0)58 589 23 33

E-mail: pes@ch.abb.com

abb.com/synchrotact