

# ControlMaster CM15

## Universal process indicator, 1/8 DIN

Making process control easy



### Comprehensive display of process status

- Crystal-clear, full-color TFT display
- User-customizable

### Exceptionally easy to use

- Intuitive user interface and clear text prompts make installation, commissioning and operation quick and simple

### Comprehensive I/O

- 2 universal inputs, 1 analog output and 1 relay fitted as standard

### Frequency input

- Direct, high accuracy connection to electromagnetic flowmeters

### Scalable to match application requirements

- Comprehensive hardware and software options

### Totalization and counter functions

- Calculation and display of flow total values
- Pulse counting capability

### Problem-solving capability

- Flexible functionality including math, logic and totalization providing power to solve complex application requirements

### Built to survive

- IP 66 and NEMA 4X environmental protection

### Flexible connectivity

- Ethernet and MODBUS® communications

# ControlMaster CM15

## Universal process indicator, 1/8 DIN

### Overview

The ControlMaster CM15 is a feature-packed, 1/8 DIN, universal process indicator. A crystal-clear, full-color, TFT display shows operators exactly the information they need to know and provides operation and configuration menus in full text making the CM15 intuitive to use and very quick to install and commission.

Available as a basic indication-only model, or enhanced through plug and play function keys and I/O modules, the CM15 offers totalization, level, math, logic, counter and alarm functions making it extremely flexible and able to solve many demanding application requirements.

MODBUS and Ethernet communication options ensure easy integration and connectivity to supervisory or control systems.

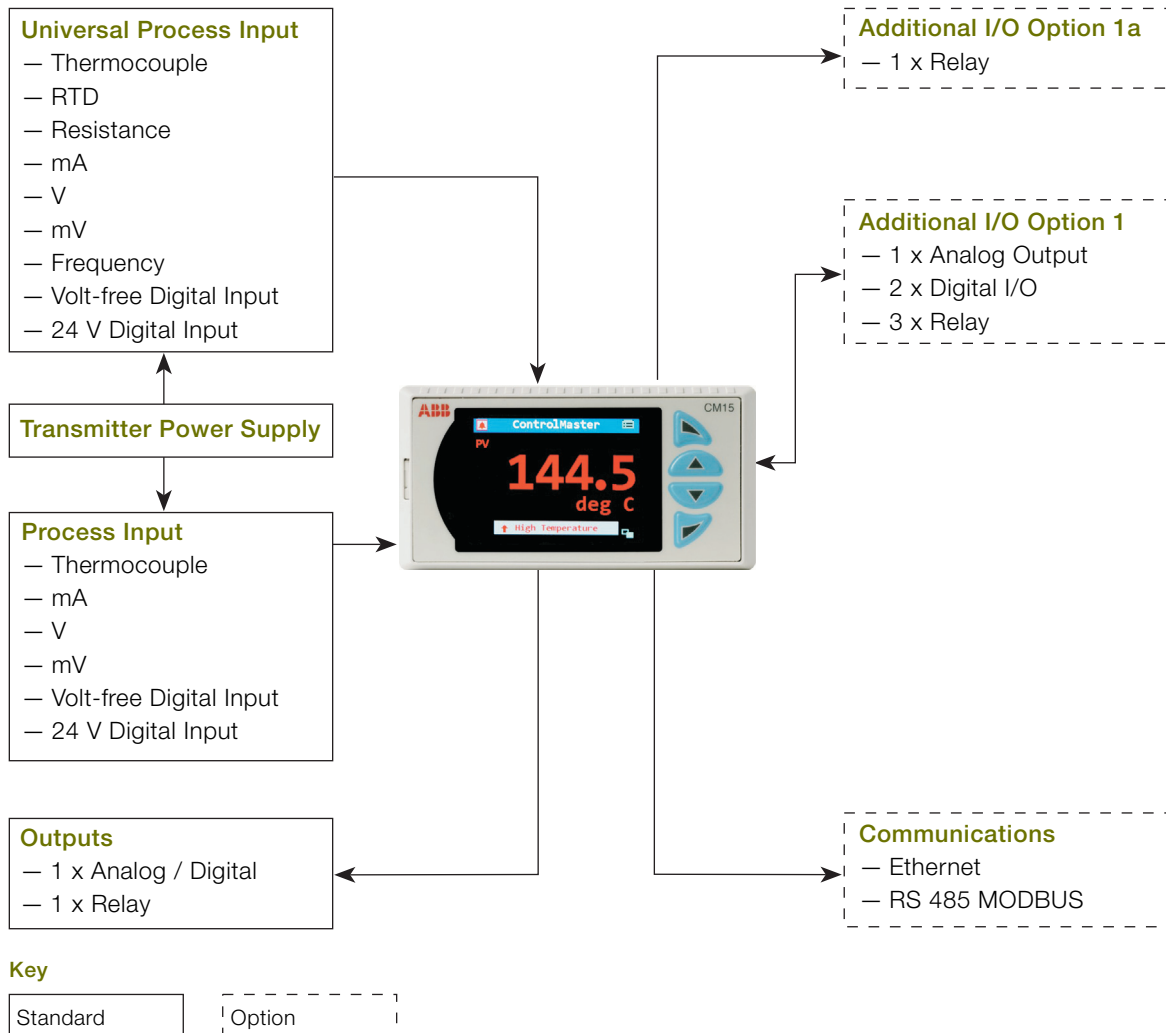

## Highly scalable

The CM15 is highly scalable in terms of both hardware and software, enabling it to meet the demands of simple indication duties through to more complex applications. The basic CM15 provides basic indication, totalization and level functionality. Templates and functionality can be increased by adding function keys to the basic model as shown in Fig. 1, while retaining previous templates and functionality.



Level	Function Keys	Template	Functionality
Base	0 	Single PV indication Single PV with totalizer Single totalizer Single level with volume	Process alarms Totalization Volume computation – Specific gravity compensation Minimum, maximum and average calculation
Standard	1 		Logic Math Custom linearizers Delay timers Real time alarms Template customization
Dual	2 	Dual PV indication Dual PV with totalizer Dual totalizer Dual level with volume	Display customization

Fig. 1: Overview of template options

# ControlMaster CM15

## Universal process indicator, 1/8 DIN

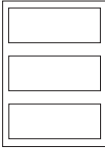
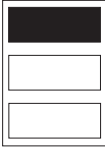
### Powerful operator display

The CM15 features a full-color 5.5 cm (2.2 in.) display for displaying detailed process information to the user. Process details such as alarm messages and diagnostic information are displayed clearly in full text without the need for difficult-to-read scrolling displays.

#### Example of an operator page

Automatic selection of standard display templates immediately makes best use of the CM15's display. Extensive customization features then enable the displayed information to be tailored to suit the process requirements.

### Diagnostics and alarm status display

The diagnostics and alarm status display provides detailed information on any active alarm or diagnostic condition. The operator can see, at-a-glance, the status of any alarm condition present within the process. Additionally, diagnostic messages are presented clearly to the operator, enabling rapid notification and simple diagnosis of any critical instrument status condition.

Historical information of diagnostic messages can also be viewed in the indicator's diagnostic log.

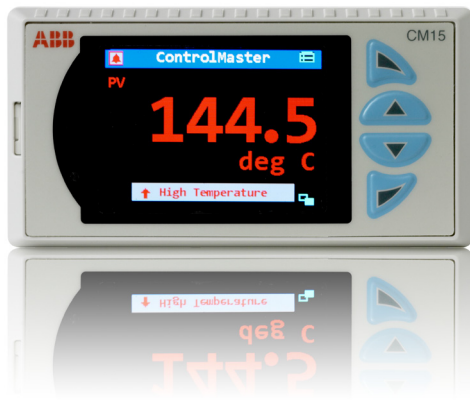

Fig. 2: Single PV indication template display

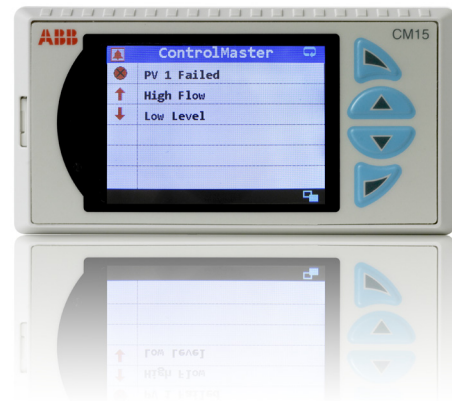

Fig. 4: Alarm status display

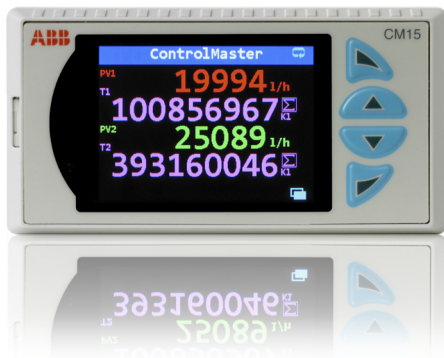

Fig. 3: Dual PV and totalization display

## Exceptionally easy to use

The CM15's full text display and simple-to-navigate, pop-up menu makes operation exceptionally easy.

A programmable soft key enables commonly used functions, such as alarm acknowledgement and display selection, to be accessed easily by the operator.

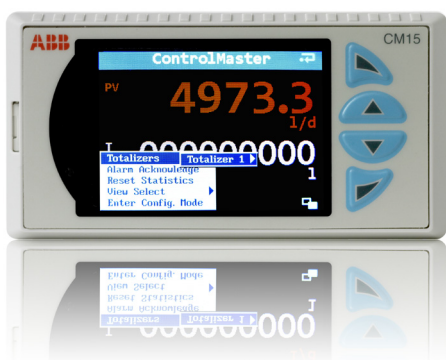

Fig. 5: Pop-up menu

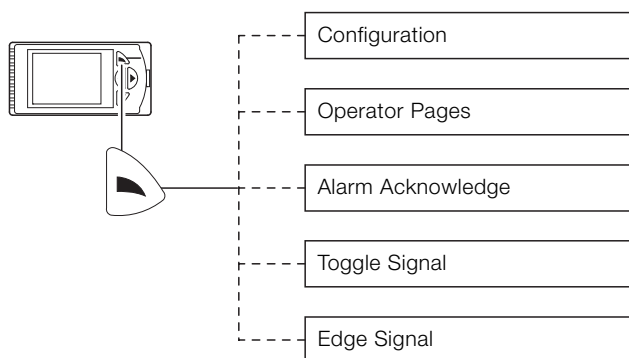

Fig. 6: Programmable soft key

# ControlMaster CM15

## Universal process indicator, 1/8 DIN

### Problem solving flexibility

Extensive functionality is available to provide flexible problem-solving capability; making the CM15 much more than just a process indicator.

#### Process alarms

8 independent process alarms can monitor any analog signal within the CM15, enabling extensive process monitoring capability. Alarms can be used to drive physical outputs or soft-wired to other functions within the indicator.

#### Real-time alarms

The 'alarm clock' functionality provided by the CM15's real-time alarms enables time-of-day decisions to be introduced into the indicator's actions or specific functions to be triggered routinely at specified times.

#### Delay timers

Event sequencing is enabled through the use of the CM15's delay timers. A predetermined delay and output duration can be programmed into each delay timer and timers can be linked together.

#### Custom linearizers

The CM15 has 2 independent 20-point custom linearizers that can be applied to any analog signal within the indicator. These linearizers can be used in applications such as level-to-volume conversion of a non-linear tank level or to accommodate special input signals or output devices.

#### Math

8 math blocks provide arithmetic, averaging, min. / max. hold, square root and signal switching functionality. Simple equations can be performed in a single math block or multiple math blocks can be nested together to construct complex equations.

Signal switching 'multiplexing' math blocks switch between 2 analog signals based on a trigger signal. For example, a backup sensor could be selected automatically on failure of a primary sensor.

#### Logic

8 comprehensive logic equations provide powerful interlock functionality. Inputs and outputs of the logic equations can be soft-wired to any digital signal within the indicator to maximize flexibility.

#### Totalizer

2 totalizers are available on the CM15. The totalizers can be configured to perform multiple functions:

- integration against an analog signal to totalize flow
- counting digital pulses
- totalization of flow based on a frequency signal from an electromagnetic flow meter

#### Frequency input

For maximum accuracy the CM15 can accept a frequency signal from an electromagnetic flow meter. The frequency signal can be totalized and displayed; an instantaneous flow rate can also be calculated and displayed on screen.

## Communications

Extensive communication options enable the CM15 to be integrated into larger control systems easily or connected to other process instrumentation.

### Ethernet

Optional Ethernet communications enable ControlMaster to be integrated in to an Ethernet network quickly. The following functionality is provided:

#### – Email

Notification of a critical process event or status can be made by email. Multiple events can trigger an email that can be sent to multiple recipients

#### – Webserver

ControlMaster's integrated webserver enables the current status of the process and indicator to be viewed remotely using a standard web browser

#### – MODBUS TCP

Process values and status can be communicated to and from the CM15 in real-time using MODBUS TCP, enabling it to be integrated easily into larger control systems or connected to a data recorder

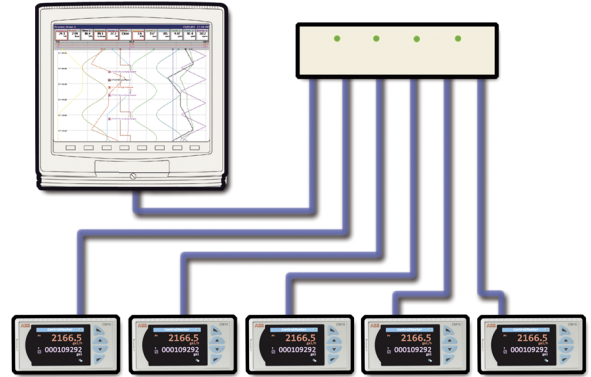

Fig. 8: ControlMasters connected to a ScreenMaster

### RS 485 MODBUS

Using RS 485 MODBUS, values and status can be communicated to and from the indicator in real-time via an RS 485 connection.

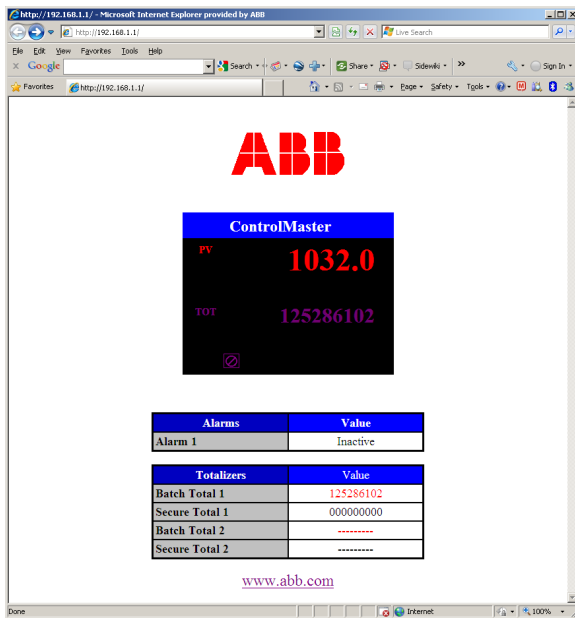

Fig. 7: Webserver

# ControlMaster CM15

## Universal process indicator, 1/8 DIN

### PC configuration

In addition to configuration via the front panel, the CM15 can be configured offline using ABB's Asset Vision Basic, a Device Type Manager (DTM)-based configuration package.

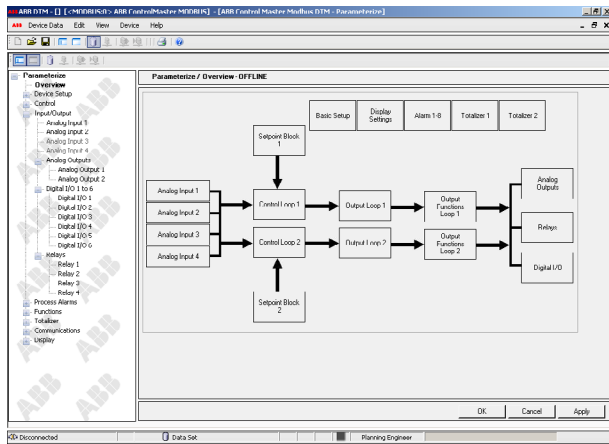

Fig. 9: PC Configuration software

Configuration files can be stored locally on a PC and transferred to the indicator via its front panel infrared port.

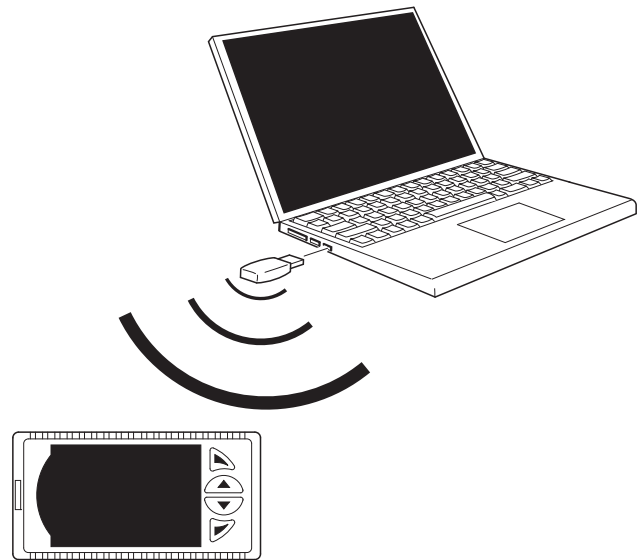

Fig. 10: Transferring a configuration file via the infrared port

PC configuration software for ControlMaster is available for download from [www.abb.com/instrumentation](http://www.abb.com/instrumentation).

## Application templates

To minimize commissioning time, the CM15 features up to 8 preconfigured templates. Simply selecting the required template configures the CM15's function blocks and display automatically. Customization of the preconfigured templates is also possible, providing the flexibility to create customized solutions.

### Single PV indication

This template provides indication of a single process value. The example in Fig. 11 shows the CM15 being used to indicate the temperature of a heat treatment furnace

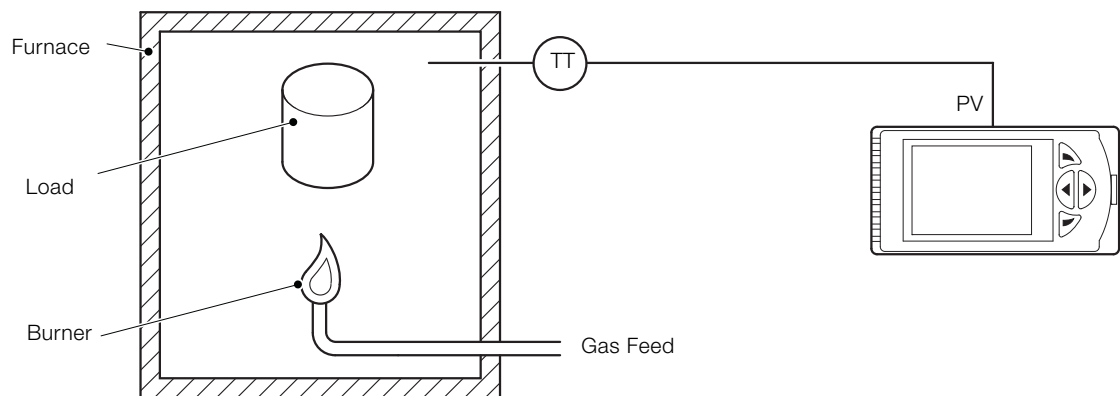

Fig. 11: Single PV indication

### Single PV with totalization

This template adds totalization to the single PV indication template. In the example in Fig. 12, the CM15 is monitoring a pipeline to provide indication of instantaneous flow rate and totalization and could be connected to the flowmeter via an analog (for example 4 to 20 mA) or frequency signal.

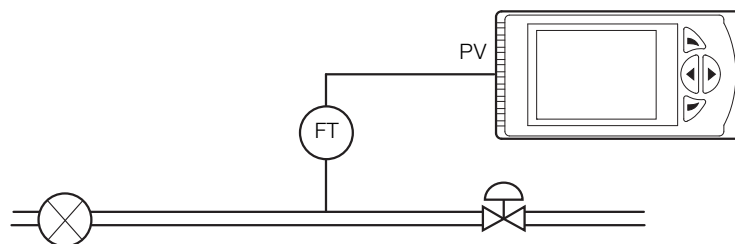

Fig. 12: Single PV with totalization

# ControlMaster CM15

## Universal process indicator, 1/8 DIN

### Single totalizer

This template provides totalization only. Fig. 13 shows the CM15 being used to count the number of products passing a specific point on a production line.

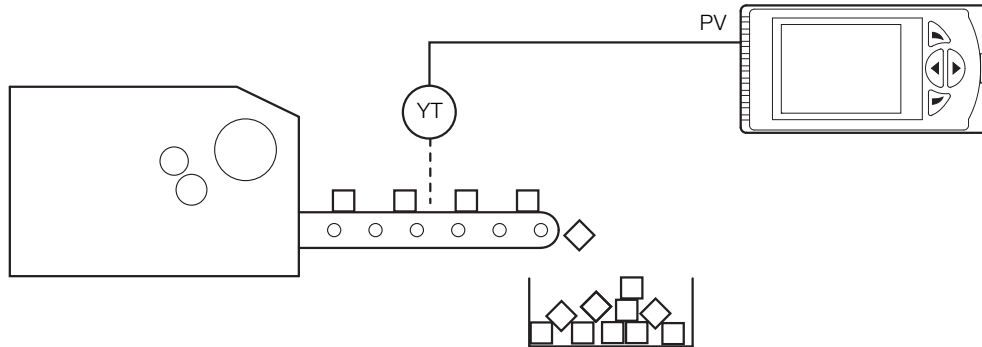

Fig. 13: Single totalizer

### Single level with volume

The single level with volume template adds level specific functions to the single PV indication template. The volume contained within a vessel can be calculated and indicated and products of varying specific gravity accounted for. In Fig. 14, the CM15 is shown monitoring the level of product in a storage tank and calculating the associated volume.

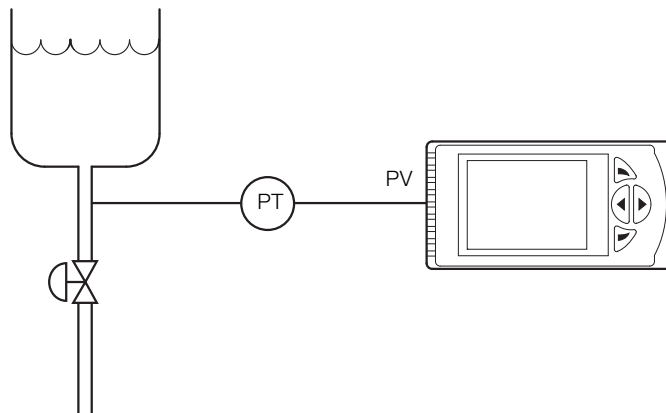

Fig. 14: Single level with volume

### Dual indication

This template provides indication of 2 process values. Variations of this template are available providing dual PV with totalization, dual totalization or dual level indication. The example in Fig. 15 shows a single CM15 providing indication of both the flow through, and temperature of, a heat exchanger.

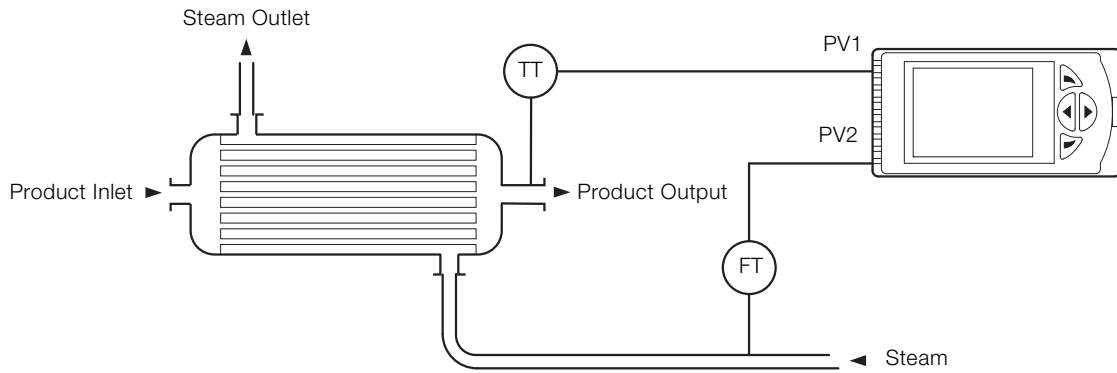

Fig. 15: Dual indication

# ControlMaster CM15

## Universal process indicator, 1/8 DIN

### Technical specification

#### Operation

##### Display

Color, 1/4 VGA TFT, liquid crystal display (LCD) with built-in backlight

##### Language

English, German, French, Italian and Spanish

##### Operator keypad

4 tactile membrane keys

#### Security

##### Password protection

Basic / Advanced – user-assigned password protection (not set at factory)

#### Standard functions

Base templates:

- Single PV indication
- Single PV indication + totalizer
- Counter
- Single PV indication + level

Dual templates

- Dual PV indication
- Dual PV indication + totalizer
- Dual counter
- Dual PV indication + level

#### Process alarms

Number:

- 8

Types:

- High / Low process
- High / Low latch

Source

- Fully configurable  
(for example – PV, Analog input, Math block inbuilt)

Hysteresis:

- Level and time

Alarm enable:

- Enable / Disable individual alarms via a digital signal

#### Acknowledgement

Via front panel keys or digital signals

#### Real-time alarms \*

Number:

- 2

Programmable:

- Time
- Day
- Duration

\* Indicator fitted with standard function key only

### Math blocks \*

Number:

- 8

Operators:

- +, –, ×, /
- Average, Maximum, Minimum
- High / Low / Median select
- Square root
- Multiplexer

### Delay timers \*

Number:

- 2

Programmable:

- Delay
- Duration

### Logic equations \*

Number:

- 8

Elements:

- 15 per equation

Operators:

- OR, AND, NOR, NAND, NOT, EXOR

### Custom linearizer \*

Number:

- 2

Elements:

- 20 breakpoints

### Analog inputs

#### Universal process inputs

Number:

- 1 standard

Type:

- Voltage
- Current
- Resistance (ohms)
- 3-Wire RTD
- Thermocouple
- Digital volt-free
- Digital 24 V
- Frequency

#### Non-universal process inputs

Number:

- 1 standard

Type:

- Voltage
- Current
- Thermocouple \*
- Digital volt-free
- Digital 24 V

### Thermocouple types

B, E, J, K, L, N, R, S, T

### Resistance thermometer

Pt100

### Other linearizations

$\sqrt{x}$ ,  $x^{3/2}$ ,  $x^{5/2}$ , custom linearization

### Digital filter

Programmable 0 to 60 s

\* Indicator fitted with standard function key only

\* Only if universal process input is configured as 'Thermocouple'

# ControlMaster CM15

## Universal process indicator, 1/8 DIN

### Display range

-9999 to 99999

### Update rate

125 ms

### Common mode noise rejection

> 120 dB at 50 / 60 Hz with 300 Ω imbalance resistance

### Normal (series) mode noise rejection

> 60 dB at 50 / 60 Hz

### CJC rejection ratio

0.05 °C/°C change in ambient temperature

### Temperature stability

0.02 %/°C or 2 μV/°C (1 μV/°F)

### Long term (input) drift

< 0.1 % of reading or 10 μV annually

### Input impedance

> 10 MΩ (mV input)

10 Ω (mA input)

### Inputs

Thermocouple	Maximum range °C (°F)	Accuracy (% of reading)
B	-18 to 1800 (0 to 3270)	0.1 % or ±2 °C (3.6 °F) (above 200 °C [392 °F]) *
E	-100 to 900 (-140 to 1650)	0.1 % or ±0.5 °C (0.9 °F)
J	-100 to 900 (-140 to 1650)	0.1 % or ±0.5 °C (0.9 °F)
K	-100 to 1300 (-140 to 2350)	0.1 % or ±0.5 °C (0.9 °F)
L	-100 to 900 (-140 to 1650)	0.1 % or ±1.5 °C (2.7 °F)
N	-200 to 1300 (-325 to 2350)	0.1 % or ±0.5 °C (0.9 °F)
R	-18 to 1700 (0 to 3000)	0.1 % or ±1 °C (1.8 °F) (above 300 °C [540 °F]) *
S	-18 to 1700 (0 to 3000)	0.1 % or ±1 °C (1.8 °F) (above 200 °C [392 °F]) *
T	-250 to 300 (-400 to 550)	0.1 % or ±0.5 °C (0.9 °F) (above -150 °C [-238 °F]) *

\* Accuracy is not guaranteed at temperatures below this value

RTD	Maximum range °C (°F)	Accuracy (% of reading)
Pt100	-200 to 600 (-325 to 1100)	0.1 % or ±0.5 °C (0.9 °F)

Linear inputs	Standard analog input	Accuracy (% of reading)
Millivolts	0 to 150 mV	0.1 % or ±20 μV
Milliamperes	0 to 50 mA	0.2 % or ±4 μA
Volts	0 to 25 V	0.2 % or ±20 mV
Resistance (low)	0 to 550 Ω	0.2 % or ±0.1 Ω
Resistance (high)	0 to 10 kΩ	0.5 % or ±10 Ω
Sample Interval	125 ms per sample	

### Digital inputs

Type	Volt-free or 24 V
Minimum pulse duration	Single input configured – 250 ms Both inputs configured as analog or digital – 500 ms

### Frequency input\*

Frequency range	0 to 6000 Hz
1-signal	15 to 30 V
0-signal	-3 to 5 V

\*For use with devices with open collector outputs

## Outputs

### Retransmission outputs

Number:

- 2 (1 standard, 1 optional)

Isolation:

- Galvanically isolated from the rest of the circuitry, 500 V for 1 minute

Analog range:

- 0 to 20 mA programmable

Load:

- 750  $\Omega$  max.

Accuracy:

- 0.2 % of output or  $\pm 10 \mu\text{VA}$

### Relays

Number:

- 4 (1 standard, 3 optional)

Type:

- Standard with changeover contacts
- Optional contacts selectable as NO or NC (by jumper)

Relay 1 contact rating:

- 5 A, 240 V

Relay 2, 3 and 4 contact ratings at maximum ambient temperature of 40 °C (104 °F):

- 5 A, 240 V

Relay 2, 3 and 4 contact ratings at maximum ambient temperature of 55 °C (131 °F):

- 2 A, 240 V

Update rate:

- 125 ms

## Digital I/O

Number:

- 2 (optional)

Type:

- User-programmable as input or output
- Minimum input pulse duration – 125 ms

Input:

- Volt-free or 24 V DC
- 1-signal 15 to 30 V
- 0-signal –3 to 5 V
- Conforms to IEC 61131-2

Output:

- Open collector output
- 30 V, 100 mA max. switched
- Conforms to IEC 61131-2

Update rate:

- 125 ms

### 2-Wire transmitter power supply

Number:

- 1 standard

Voltage:

- 24 V DC

Drive:

- 2 loops, 45 mA max.

# ControlMaster CM15

## Universal process indicator, 1/8 DIN

### Communications

**Note.** Only one communications option can be fitted per indicator.

### IrDA service port (standard)

Baud rate:

- Up to 115 kBaud

Distance:

- Up to 1 m (3 ft)

Functions:

- Firmware upgrade
- Configuration upload / download

### Ethernet (optional)

Type:

- 10BaseT

Connector:

- RJ 45

Protocols:

- TCP/IP
- HTTP
- MODBUS TCP (Slave)

Web server:

- Built-in – enables remote monitoring using standard web browsers

Email:

- Can be configured to be sent on the occurrence of a specified event
- Up to 3 recipients
- Up to 4 trigger sources with configurable tag

### MODBUS \* RTU (optional)

Baud rate:

- Up to 115 kBaud

Isolation:

- Galvanically isolated from the rest of the circuitry, 500 V DC for 1 minute

\* MODBUS is a registered trademark of the MODBUS-IDA organization

## EMC

### Emissions & immunity

Meets requirements of IEC 61326 for an Industrial Environment

## Environmental

### Operating temperature range

0 to 55 °C (32 to 131 °F) \*

### Operating humidity range

5 to 95 % RH (non-condensing)

### Storage temperature range

-20 to 70 °C (-4 to 158 °F)

### Enclosure sealing

Front face:

— IP 66 & NEMA 4X

Rest of enclosure:

— IP 20

## Safety

### Approvals and certifications

EN 61010-1

cULus

### General safety

Overvoltage Class III on mains, Class II on inputs and outputs

Pollution category 2

Insulation category 2

### Isolation

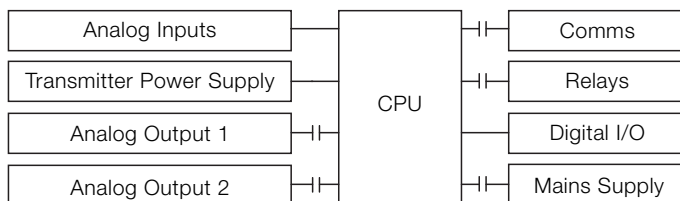

## Key

—||— = Isolation

## Electrical

### Supply ranges

100 V to 240 V AC  $\pm 10\%$  (90 V min. to 264 V max.) 50 / 60 Hz  
10 to 36 V DC (optional)

### Power consumption

10 W max.

### Power interruption protection

No effect for interrupts of up to 60 ms

## Physical

### Size

50 x 97 x 141 mm (2.0 x 3.8 x 5.5 in.)

### Weight

0.38 kg (0.84 lb) approx. (unpacked)

### Panel cutout

45 x 92 mm (1.8 x 3.6), 120 mm (4.8 in.) behind panel

### Case material

Glass-filled polycarbonate

\* Restrictions may apply – refer to relay specification on page 15

# ControlMaster CM15

## Universal process indicator, 1/8 DIN

### Electrical connections

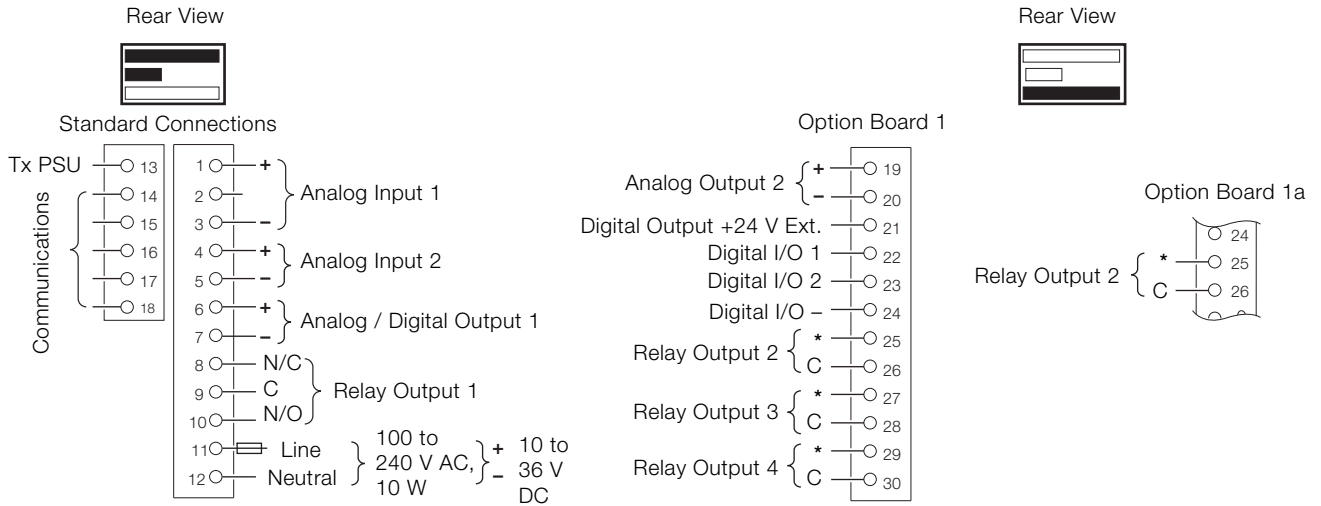

\* N/O or N/C selection made via jumper

### Overall dimensions

Dimensions in mm (in.)

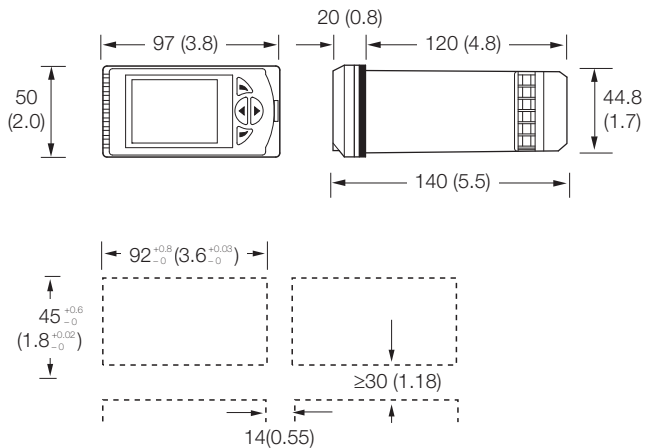

### Standard accessories

Included with each indicator:

- Panel mounting clamps
- Instruction manual
- Bezel release tool
- Cold junction thermistor

### Optional accessories

- PC configuration kit CM30/0712

## Ordering information

ControlMaster CM15 universal process indicator, 1/8 DIN	CM15/	X	X	X	X	X	X	X	/XXX
<b>I/O build</b>									
2 analog inputs, 1 analog O/P and 1 relay (Basic)		0							
2 analog inputs, 1 analog output and 2 relays (Basic + option board 1a)		1							
2 analog inputs, 2 analog outputs, 2 digital I/O and 4 relays (Basic + option board 1)		2							
<b>Template / Functionality level</b>									
Base			0						
Standard			S						
Dual point indication			D						
<b>Communications</b>									
None				0					
Ethernet				E					
RS 485 MODBUS				M					
<b>Approval</b>									
Standard CE					S				
cULus approval					U				
<b>Power supply</b>									
100 ... 240 V AC						0			
10 ... 36 V DC						1			
<b>Language</b>									
English							E		
German							G		
French							F		
Italian							I		
Spanish							S		
<b>Special features</b>									
None								0	
Unbranded front panel								B	
<b>Configuration</b>									
Standard									STD
Custom programming									CUS

# Contact us

## **ABB Limited**

### **Process Automation**

Howard Road

St. Neots

Cambridgeshire PE19 8EU

UK

Tel: +44 (0)1480 475321

Fax: +44 (0)1480 217948

## **ABB Inc.**

### **Process Automation**

125 E. County Line Road

Warminster

PA 18974

USA

Tel: +1 215 674 6000

Fax: +1 215 674 7183

[www.abb.com](http://www.abb.com)

## Note

We reserve the right to make technical changes or modify the contents of this document without prior notice. With regard to purchase orders, the agreed particulars shall prevail. ABB does not accept any responsibility whatsoever for potential errors or possible lack of information in this document.

We reserve all rights in this document and in the subject matter and illustrations contained therein. Any reproduction, disclosure to third parties or utilization of its contents in whole or in parts – is forbidden without prior written consent of ABB.

Copyright© 2011 ABB

All rights reserved

3KXC401501R1001