

HIMax[®]

Analog Output Module Manual

SAFETY
NONSTOP



X-AO 16 01

All HIMA products mentioned in this manual are protected by the HIMA trade-mark. Unless noted otherwise, this also applies to other manufacturers and their respective products referred to herein.

All of the instructions and technical specifications in this manual have been written with great care and effective quality assurance measures have been implemented to ensure their validity. For questions, please contact HIMA directly. HIMA appreciates any suggestion on which information should be included in the manual.

Equipment subject to change without notice. HIMA also reserves the right to modify the written material without prior notice.

For further information, refer to the CD-ROM and our website <http://www.hima.de> and <http://www.hima.com>.

© Copyright 2011, HIMA Paul Hildebrandt GmbH + Co KG

All rights reserved

Contact

HIMA contact details:

HIMA Paul Hildebrandt GmbH + Co KG

P.O. Box 1261

68777 Brühl, Germany

Phone: +49 6202 709-0

Fax: +49 6202 709-107

E-mail: info@hima.com

Revision index	Revisions	Type of Change	
		technical	editorial
4.00	New edition for SILworX V4	X	X

Table of Contents

1	Introduction	5
1.1	Structure and Use of this Manual	5
1.2	Target Audience	5
1.3	Formatting Conventions	6
1.3.1	Safety Notes	6
1.3.2	Operating Tips	7
2	Safety	8
2.1	Intended Use	8
2.1.1	Environmental Requirements	8
2.1.2	ESD Protective Measures	8
2.2	Residual Risk	9
2.3	Safety Precautions	9
2.4	Emergency Information	9
3	Product Description	10
3.1	Safety Function	10
3.1.1	Reaction in the Event of a Fault	10
3.2	Scope of Delivery	10
3.3	Type Label	11
3.4	Structure	12
3.4.1	Block Diagram	12
3.4.2	Indicators	13
3.4.3	Module Status Indicators	14
3.4.4	System Bus Indicators	15
3.4.5	I/O Indicators	15
3.5	Product Data	16
3.6	Connector Boards	18
3.6.1	Mechanical Coding of Connector Boards	18
3.6.2	Coding of X-CB 014 Connector Boards	19
3.6.3	Connector Board with Screw Terminals	20
3.6.4	Terminal Assignment for Mono Connector Boards with Screw Terminals	21
3.6.5	Terminal Assignment for Redundant Connector Boards with Screw Terminals	22
3.6.6	Connector Board with Cable Plug	23
3.6.7	Pin Assignment for Mono Connector Boards with Cable Plug	24
3.6.8	Pin Assignment for Redundant Connector Boards with Cable Plug	25
3.7	System Cable X-CA 011	26
3.7.1	Cable Plug Coding	27

4	Start-up	28
4.1	Mounting	28
4.1.1	Wiring Outputs not in Use	28
4.2	Mounting and Removing the Module.....	29
4.2.1	Mounting a Connector Board	29
4.2.2	Mounting and Removing the Module.....	31
4.3	Configuring the Module in SILworX.....	33
4.3.1	Tab: Module	34
4.3.2	Tab: I/O Submodule AO16_01	35
4.3.3	Tab: I/O Submodule AO16_01: Channels.....	36
4.3.4	Submodule Status [DWORD].....	37
4.3.5	Diagnostic Status [DWORD].....	38
4.4	Connection Variants.....	39
4.4.1	Single-Channel Wiring.....	39
4.4.2	Redundant Wiring (Serial Connection).....	39
4.4.3	Closed Loop Control.....	40
4.4.4	Connection via Field Termination Assembly	41
4.4.5	Characteristics of HART Communication	41
5	Operation	42
5.1	Handling	42
5.2	Diagnosis	42
6	Maintenance	43
6.1	Maintenance Measures	43
6.1.1	Loading the Operating System	43
6.1.2	Proof Test.....	43
7	Decommissioning	44
8	Transport	45
9	Disposal	46
	Appendix	48
	Glossary	48
	Index of Figures.....	49
	Index of Tables	50
	Index	51

1 Introduction

The present manual describes the technical characteristics of the module and its use. It provides information on how to install, start up and configure the module in SILworX.

1.1 Structure and Use of this Manual

The content of this manual is part of the hardware description of the HIMax programmable electronic system.

This manual is organized in the following main chapters:

- Introduction
- Safety
- Product Description
- Start-up
- Operation
- Maintenance
- Decommissioning
- Transport
- Disposal

Additionally, the following documents must be taken into account:

Name	Content	Document no.
HIMax System manual	Hardware description of the HIMax system	HI 801 001 E
HIMax Safety manual	Safety functions of the HIMax system	HI 801 003 E
HIMax Communication manual	Description of communication and protocols	HI 801 101 E
SILworX Online Help (OLH)	Instructions on how to use SILworX	-
First Steps	Introduction to SILworX	HI 801 103 E

Table 1: Additional Relevant Manuals

The latest manuals can be downloaded from the HIMA website at www.hima.com. The revision index on the footer can be used to compare the current version of existing manuals with the Internet edition.

1.2 Target Audience

This document addresses system planners, configuration engineers, programmers of automation devices and personnel authorized to implement, operate and maintain the devices and systems. Specialized knowledge of safety-related automation systems is required.

1.3 Formatting Conventions

To ensure improved readability and comprehensibility, the following fonts are used in this document:

Bold:	To highlight important parts Names of buttons, menu functions and tabs that can be clicked and used in SILworX.
<i>Italics:</i>	System parameter and variables
Courier	Literal user inputs
RUN	Operating state are designated by capitals
Chapter 1.2.3	Cross references are hyperlinks even though they are not particularly marked. When the cursor hovers over a hyperlink, it changes its shape. Click the hyperlink to jump to the corresponding position.

Safety notes and operating tips are particularly marked.

1.3.1 Safety Notes

The safety notes are represented as described below.

These notes must absolutely be observed to reduce the risk to a minimum. The content is structured as follows:

- Signal word: danger, warning, caution, notice
- Type and source of danger
- Consequences arising from the danger
- Danger prevention

SIGNAL WORD



Type and source of danger!
Consequences arising from the danger
Danger prevention

The signal words have the following meanings:

- Danger indicates hazardous situation which, if not avoided, will result in death or serious injury.
- Warning indicates hazardous situation which, if not avoided, could result in death or serious injury.
- Notice indicates hazardous situation which, if not avoided, could result in minor or modest injury.
- Notice indicates a hazardous situation which, if not avoided, could result in property damage.

NOTICE



Type and source of damage!
Damage prevention

1.3.2 Operating Tips

Additional information is structured as presented in the following example:

i

The text corresponding to the additional information is located here.

Useful tips and tricks appear as follows:

TIP

The tip text is located here.

2 Safety

All safety information, notes and instructions specified in this manual must be strictly observed. The product may only be used if all guidelines and safety instructions are adhered to.

This product is operated in accordance with SELV or PELV. No imminent danger results from the module itself. The use in Ex-Zone is permitted if additional measures are taken.

2.1 Intended Use

HIMax components are designed for assembling safety-related controller systems.

When using the components in the HIMax system, comply with the following general requirements

2.1.1 Environmental Requirements

Requirement type	Range of values
Protection class	Protection class III in accordance with IEC/EN 61131-2
Ambient temperature	0...+60 °C
Storage temperature	-40...+85 °C
Pollution	Pollution degree II in accordance with IEC/EN 61131-2
Altitude	< 2000 m
Housing	Standard: IP20
Supply voltage	24 VDC

Table 2: Environmental Requirements

Exposing the HIMax system to environmental conditions other than those specified in this manual can cause the HIMax system to malfunction.

2.1.2 ESD Protective Measures

Only personnel with knowledge of ESD protective measures may modify or extend the system or replace modules.

NOTE



Device damage due to electrostatic discharge!

- When performing the work, make sure that the working area is free of static and wear an ESD wrist strap.
- If not used, ensure that the device is protected from electrostatic discharge, e.g., by storing it in its packaging.

2.2 Residual Risk

No imminent danger results from a HIMax module itself.

Residual risk may result from:

- Faults in the engineering
- Faults in the user program
- Faults in the wiring

2.3 Safety Precautions

Observe all local safety requirements and use the protective equipment required on site.

2.4 Emergency Information

A HIMax controller is a part of the safety equipment of a system. If the controller fails, the system adopts the safe state.

In case of emergency, no action that may prevent the HIMax systems from operating safely is permitted.

3 Product Description

The X-AO 16 01 analog output module is intended for use in the programmable electronic system (PES) HIMax.

The module can be inserted in any of the base plate slots with the exception of the slots reserved for system bus modules. For more information, refer to the System Manual (HI 801 001 E).

The module is equipped with 16 analog outputs with a nominal range of 4...20 mA.

i

If two modules are redundantly connected, only 8 odd outputs are available, see Chapter 3.4.

The analog outputs are suitable for connecting ohmic, inductive and capacitive loads and lamps in accordance with EN 61131-2.

The module has been certified by the TÜV for safety-related applications up to SIL 3 (IEC 61508, IEC 61511 and IEC 62061), Cat. 4 (EN 954-1) and PL e (EN ISO 13849-1).

Refer to the HIMax Safety Manual for more information on the standards used to test and certify the modules and the HIMax system.

3.1 Safety Function

The module ensures its safety function using one extra safety switch for each channel pair that is opened if a failure occurs.

The safety function is performed in accordance with SIL 3.

3.1.1 Reaction in the Event of a Fault

If the safety-related processor system of the module detects a module fault during operation, the module adopts the safe state after a maximum of 16 ms and all the outputs are de-energized in accordance with the 'de-energize to trip principle'. If a channel fault occurs, both channels of the affected channel group are switched off.

The module activates the *Error* LED on the front plate.

3.2 Scope of Delivery

The module must be installed on a suitable connector board to be able to operate. If a FTA is used, a system cable is required to connect the connector board to the FTA. Connector boards, system cables and FTAs are not included within the scope of delivery.

The connector boards are described in Chapter 3.6, the system cables are described in Chapter 3.7. The FTAs are described in own manuals.

3.3 Type Label

The type label specifies the following important details:

- Product name
- Mark of conformity
- Bar code (2D or 1D code)
- Part number (Part-No.)
- Hardware revision index (HW Rev.)
- Software revision index (SW Rev.)
- Operating voltage (Power)
- Ex specifications (if applicable)
- Production year (Prod-Year:)

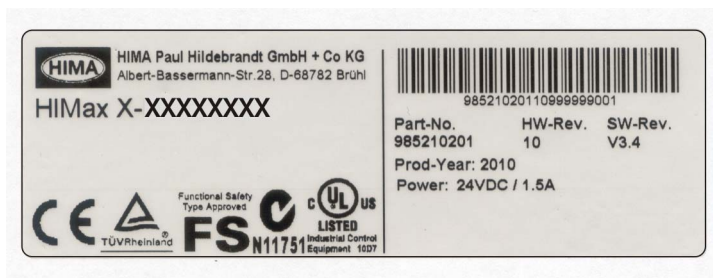

Figure 1: Sample Type Label

3.4 Structure

The module is equipped with 16 analog current outputs (0/4...20 mA) that are pairwise electrically isolated from the supply voltage and the remaining channel pairs. The analog current value is set with a D/A converter, measured by two independent, internal measuring devices and functionally tested.

If two modules are redundantly connected, only 8 odd outputs (AO1, AO3...AO15) are available. The even outputs (AO2, AO4...AO16) are not used.

The module automatically diagnosis open-circuits (OC) and can be evaluated in the user program, see Chapter 4.3.

The safety-related 1oo2 processor system for the I/O module controls and monitors the I/O level. The data and states of the I/O module are made available to the processor modules via the redundant system bus. The system bus has a redundant structure for reasons of availability. Redundancy is only ensured if both system bus modules are inserted in the base plates and configured in SILworX.

3.4.1 Block Diagram

The following block diagram illustrates the structure of the module.

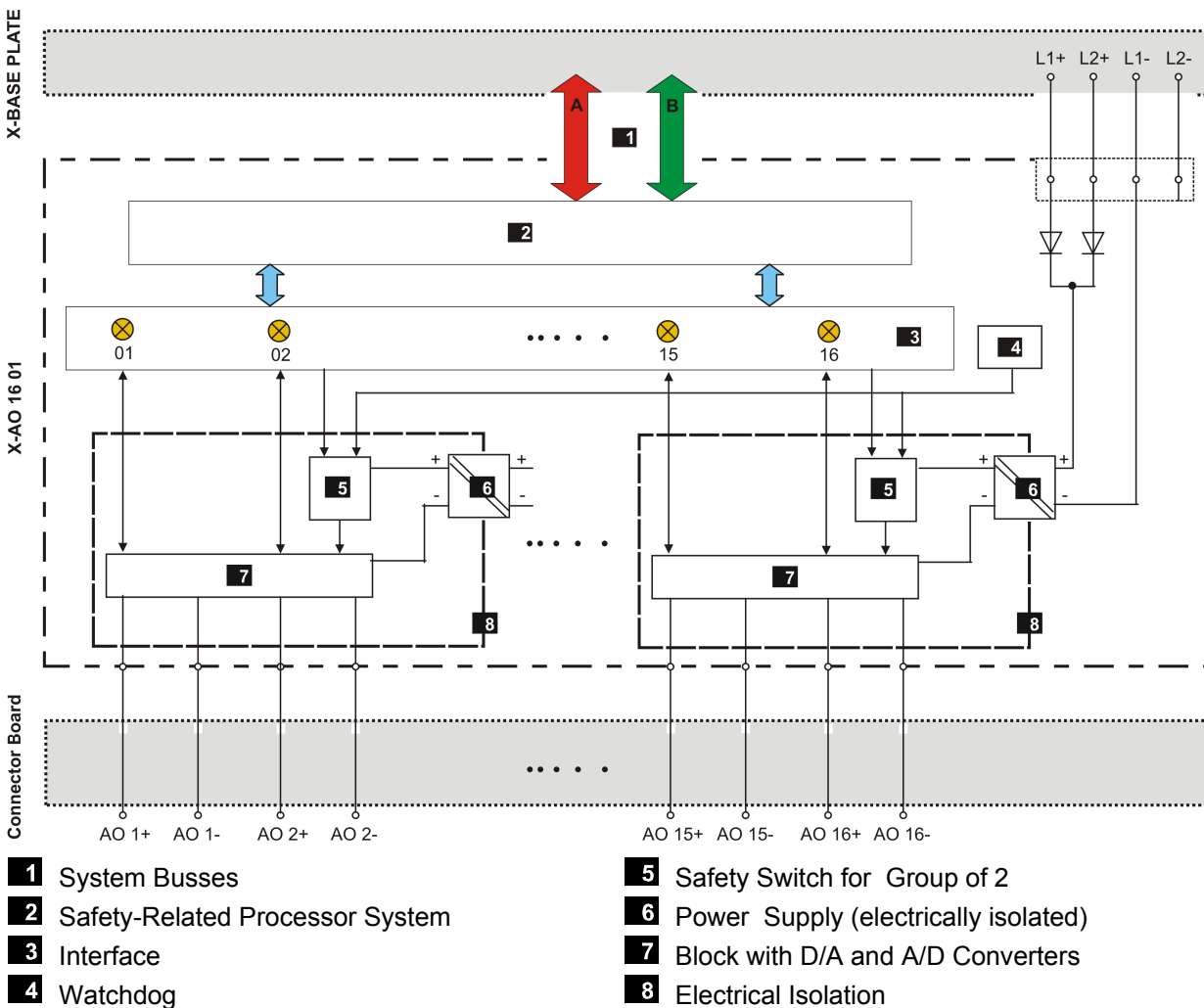

Figure 2: Module's Block Diagram

3.4.2 Indicators

The following figure shows the LED indicators for the module.

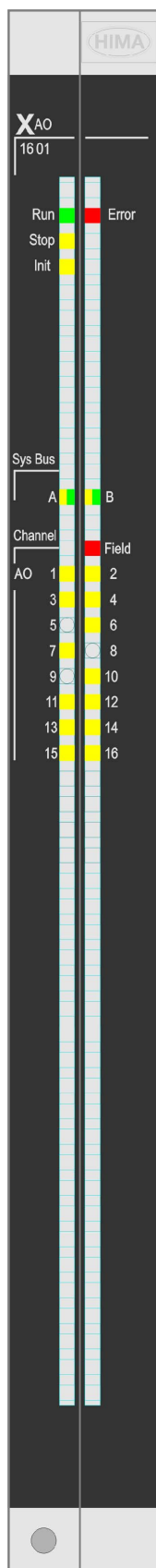

Figure 3: Indicators

The LEDs indicate the operating state of the module.

The LEDs on the module are divided into three groups:

- Module status indicators (Run, Error, Stop, Init)
- System bus indicators (A, B)
- I/O indicators (AO 1...16, Field)

When the supply voltage is switched on, a LED test is performed and all LEDs briefly flash simultaneously.

Definition of Blinking Frequencies

The following table defines the blinking frequencies of the LEDs:

Name	Blinking Frequencies
Blinking1	Long (approx. 600 ms) on, long (approx. 600 ms) off
Blinking2	Short (approx. 200 ms) on, short (approx. 200 ms) off, short (approx. 200 ms) on, long (approx. 600 ms) off
Blinking-x	Ethernet communication: Flashing in sync with data transfer

Table 3: Blinking Frequencies of LEDs

3.4.3 Module Status Indicators

These LEDs are located on the front plate, on the upper part of the module.

LED	Color	Status	Description
Run	Green	On	Module in RUN, normal operation
		Blinking1	Module state: STOP/OS_DOWNLOAD or OPERATE (only with processor modules)
		Off	Module not in RUN, observe the other status LEDs
Error	Red	On/Blinking1	Internal module faults detected by self-tests, e.g., hardware, software or voltage supply. Fault while loading the operating system
		Off	Normal operation
Stop	Yellow	On	Module state: STOP / VALID CONFIGURATION
		Blinking1	Module state: STOP / INVALID CONFIGURATION or STOP / OS_DOWNLOAD
		Off	Module not in STOP, observe the other status LEDs
Init	Yellow	On	Module state: INIT, observe the other status LEDs
		Blinking1	Module state: LOCKED, observe to the other status LEDs
		Off	Module state: neither INIT nor LOCKED, observe the other status LEDs

Table 4: Module Status Indicators

3.4.4 System Bus Indicators

The system bus LEDs are labeled *Sys Bus*.

LED	Color	Status	Description
A	Green	On	Physical and logical connection to the system bus module in slot 1.
		Blinking1	No physical connection to the system bus module in slot 1.
	Yellow	Blinking1	The physical connection to the system bus module in slot 1 has been established. No connection to a (redundant) processor module running in system operation.
B	Green	On	Physical and logical connection to the system bus module in slot 2.
		Blinking1	No physical connection to the system bus module in slot 2.
	Yellow	Blinking1	The physical connection to the system bus module in slot 2 has been established. No connection to a (redundant) processor module running in system operation.
A+B	Off	Off	Neither physical nor logical connection to the system bus modules in slot 1 and slot 2.

Table 5: System Bus Indicators

3.4.5 I/O Indicators

The LEDs of the I/O Indicators are labeled *Channel*.

LED	Color	Status	Description
Channel 1...16	Yellow	On	The related channel is active (energized), current ≥ 4 mA.
		Blinking2	Channel fault, current not equal to set value
		Off	The related channel is inactive (de-energized), current < 4 mA.
Field	Red	Blinking2	Field fault on at least one channel or supply (e.g., open-circuit, overcurrent, etc.)
		Off	No field fault displayed!

Table 6: I/O Indicators LEDs

3.5 Product Data

General	
Supply voltage	24 VDC, -15 %...+20 %, $r_p \leq 5\%$, SELV, PELV
Current input	max. 1.3 A
Current input, all outputs are switched off.	min. 0.6 A
Current input per channel pair	80 mA
Operating temperature	0...+60 °C
Storage temperature	-40...+85 °C
Humidity	max. 95 % relative humidity, non-condensing
Type of protection	IP20
Dimensions (H x W x D) in mm	310 x 29.2 x 230
Weight	approx. 1.2 kg

Table 7: Product Data

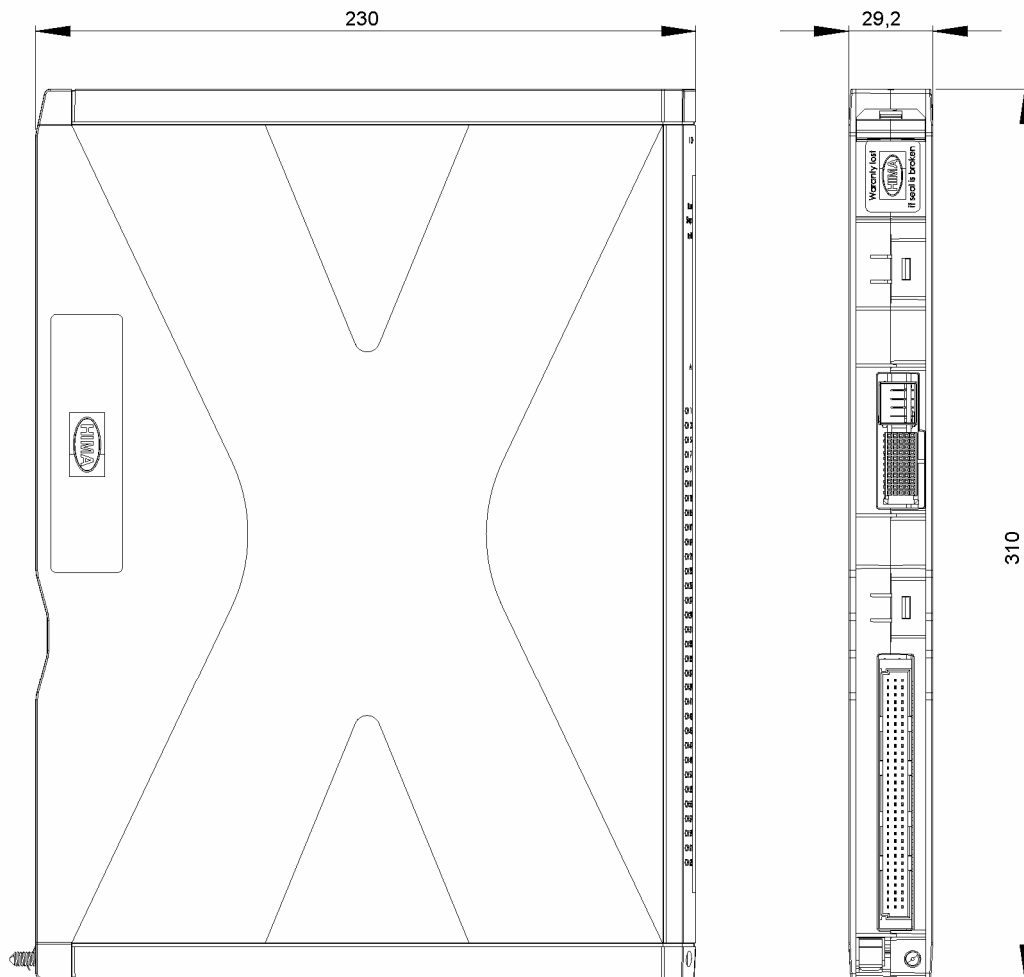

Figure 4: Views

Analog Outputs	
Number of analog outputs	16 with single channel connection. 8 with redundant connection. 2 of these outputs (AO1 and AO2; AO3 and AO4) have a common ground potential. The remaining channel pairs and the supply voltage are electrically isolated.
Nominal range	4...20 mA
Operating range	0...23 mA
Digital resolution	16-bit (10 000 digits in SILworX)
Value of LSB	$\leq 2 \mu\text{A}$
Ohmic load	max. 600 Ω
Inductive load	max. 1 mH
Capacitive load	max. 100 μF in parallel to the ohmic load
Settling time	5 ms
Shutdown time if a fault occurs (transition to the safe state)	16 ms
Metrological accuracy	
Measurement accuracy at 25 °C, max.	$\leq \pm 0.2 \%$ of final value
Metrological accuracy on full temperature, max.	$\leq \pm 0.5 \%$ of final value
Temperature coefficient, max.	$\leq \pm 0.05 \%$ / K of final value
Measurement accuracy with HART communication, max.	$\leq \pm 2 \%$ of final value
Linearity error, max.	$\leq \pm 0.1 \%$
Safety-related accuracy	$\leq \pm 2 \%$ of final value

Table 8: Specifications for the Analog Outputs

3.6 Connector Boards

A connector board connects the module to the field zone. Module and connector board form together a functional unit. Insert the connector board into the appropriate slot prior to mounting the module.

The following connector boards are available for the module:

Connector board	Description
X-CB 014 01	Connector board with screw terminals
X-CB 014 02	Redundant connector board with screw terminals
X-CB 014 03	Connector board with cable plug
X-CB 014 04	Redundant connector board with cable plug

Table 9: Available Connector Boards

3.6.1 Mechanical Coding of Connector Boards

I/O modules and connector boards are mechanically coded starting from hardware revision AS10 to prevent them from being equipped with invalid I/O modules. Coding avoids incorrect installation of invalid I/O modules thus preventing negative effects on redundant modules and field zone. A part from that, invalid equipment has no effect on the HIMax system since only I/O modules that are correctly configured in SILworX enter the RUN state.

I/O modules and the corresponding connector boards have a mechanical coding in form of wedges. The coding wedges in the female connector of the connector board match with the male connector recesses of the I/O module plug, see Figure 5.

Coded I/O modules can only be plugged in to the corresponding connector boards.

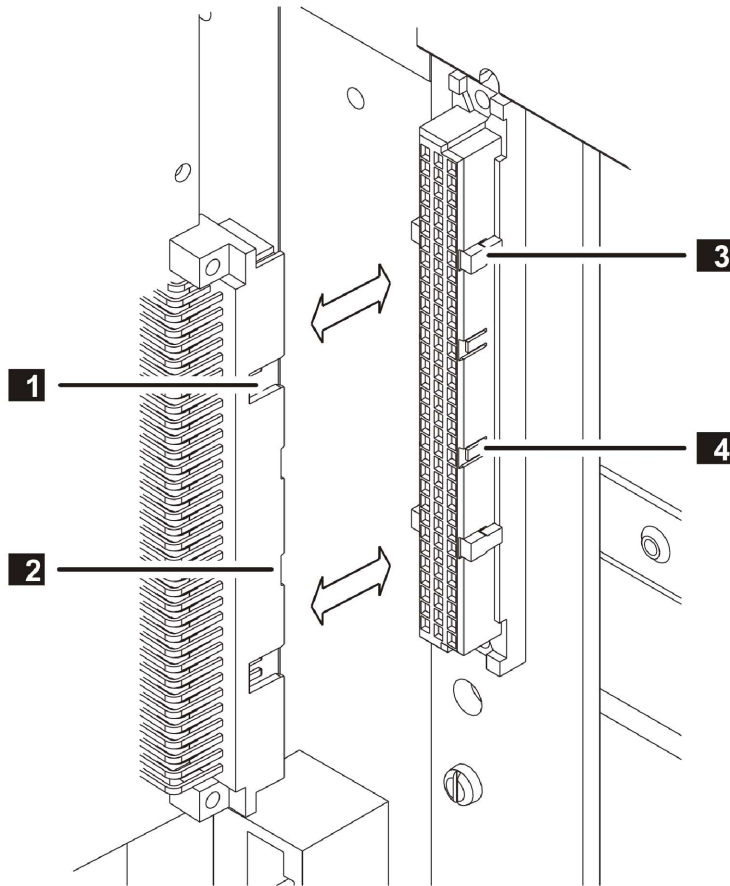

- 1** Male Connector Recess
- 2** Prepared Male Connector Recess
- 3** Coding Wedge
- 4** Guideway for Coding Wedge

Figure 5: Coding Example

Coded I/O modules can be plugged in to uncoded connector boards. Uncoded I/O modules cannot be plugged in to coded connector boards.

3.6.2 Coding of X-CB 014 Connector Boards

a7	a13	a20	a26	c7	c13	c20	c26
X	X				X	X	

Table 10: Position of Coding Wedges

3.6.3 Connector Board with Screw Terminals

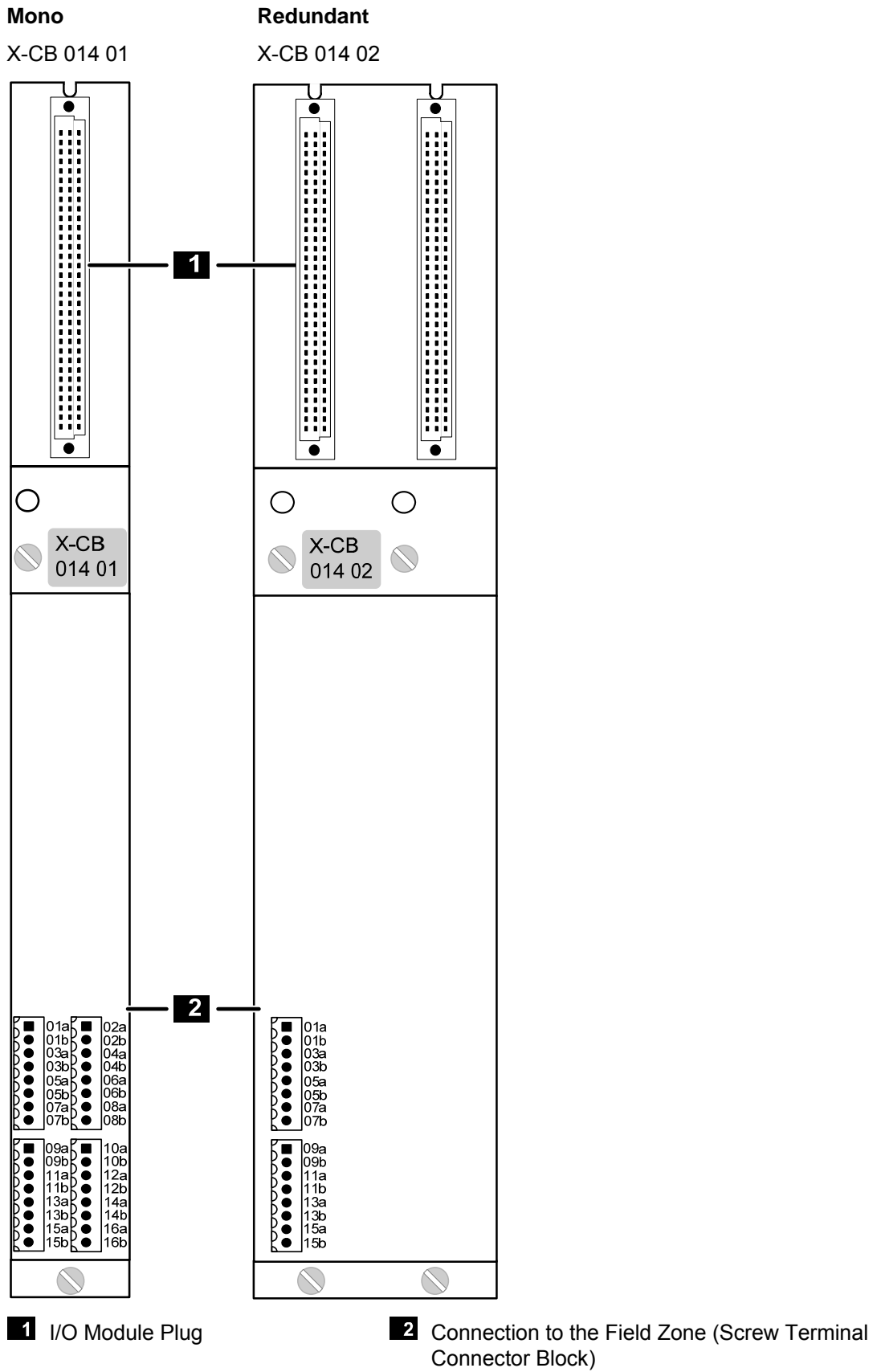

Figure 6: Connector Boards with Screw Terminals

3.6.4 Terminal Assignment for Mono Connector Boards with Screw Terminals

Pin no.	Designation	Signal	Pin no.	Designation	Signal
1	01a	AO1+	1	02a	AO2+
2	01b	AO1-	2	02b	AO2-
3	03a	AO3+	3	04a	AO4+
4	03b	AO3-	4	04b	AO4-
5	05a	AO5+	5	06a	AO6+
6	05b	AO5-	6	06b	AO6-
7	07a	AO7+	7	08a	AO8+
8	07b	AO7-	8	08b	AO8-
Pin no.	Designation	Signal	Pin no.	Designation	Signal
1	09a	AO9+	1	10a	AO10+
2	09b	AO9-	2	10b	AO10-
3	11a	AO11+	3	12a	AO12+
4	11b	AO11-	4	12b	AO12-
5	13a	AO13+	5	14a	AO14+
6	13b	AO13-	6	14b	AO14-
7	15a	AO15+	7	16a	AO16+
8	15b	AO15-	8	16b	AO16-

Table 11: Terminal Assignment for Mono Connector Boards with Screw Terminals

Cable plugs attached to the connector board pin headers are used to connect to the field zone.

The cable plugs feature the following properties:

Connection to the field zone	
Cable plugs	4 pieces, with 8 poles
Wire cross-section	0.2...1.5 mm ² (single-wire) 0.2...1.5 mm ² (finely stranded) 0.2...1.5 mm ² (with wire end ferrule)
Stripping length	6 mm
Screwdriver	Slotted 0.4 x 2.5 mm
Tightening torque	0.2...0.25 Nm

Table 12: Cable Plug Properties

3.6.5 Terminal Assignment for Redundant Connector Boards with Screw Terminals

Pin no.	Designation	Signal
1	01a	AO1+
2	01b	AO1-
3	03a	AO3+
4	03b	AO3-
5	05a	AO5+
6	05b	AO5-
7	07a	AO7+
8	07b	AO7-
Pin no.	Designation	Signal
1	09a	AO9+
2	09b	AO9-
3	11a	AO11+
4	11b	AO11-
5	13a	AO13+
6	13b	AO13-
7	15a	AO15+
8	15b	AO15-

Table 13: Terminal Assignment for Redundant Connector Boards with Screw Terminals

Cable plugs attached to the connector board pin headers are used to connect to the field zone.

The cable plugs feature the following properties:

I/O lines	
Cable plugs	2 pieces, with 8 poles
Wire cross-section	0.2...1.5 mm ² (single-wire) 0.2...1.5 mm ² (finely stranded) 0.2...1.5 mm ² (with wire end ferrule)
Stripping length	6 mm
Screwdriver	Slotted 0.4 x 2.5 mm
Tightening torque	0.2...0.25 Nm

Table 14: Cable Plug Properties

3.6.6 Connector Board with Cable Plug

Mono

X-CB 014 03

Redundant

X-CB 014 04

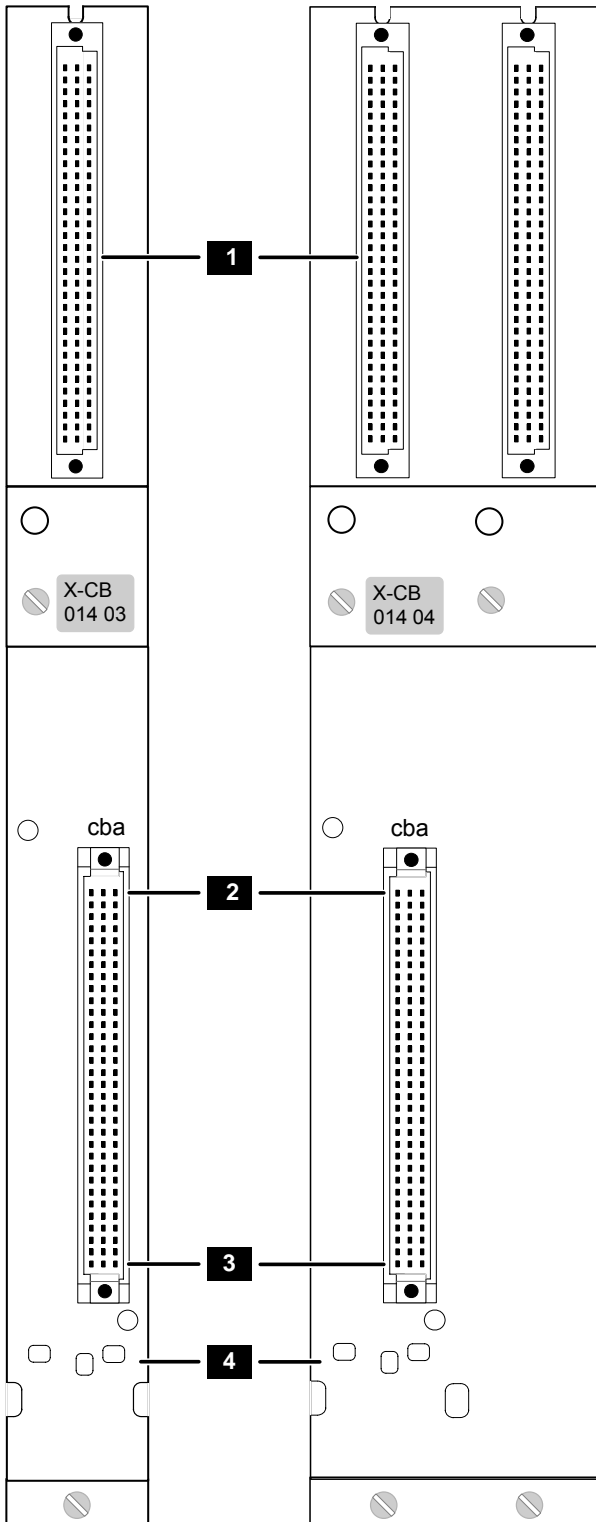

1 I/O Module Plug

2 Connection to the Field Zone (Cable Plug in Row 1)

3 Connection to the Field Zone (Cable Plug in Row 32)

4 Coding for Cable Plugs

Figure 7: Connector Boards with Cable Plug

3.6.7 Pin Assignment for Mono Connector Boards with Cable Plug

HIMA provides ready-made system cables for use with this connector board, see Chapter 3.7.

The cable plug and the connector boards are coded.

Lead marking based on DIN 47100:

Row	c		b		a	
	Signal	Color	Signal	Color	Signal	Color
1	Not used		Not used		U1-D1A	YE-BK
2	Not used		Not used		U1-D1B	GN-BK
3	Not used		Not used		U1-D2A	YE-RD
4	Not used		Not used		U1-D2B	GN-RD
5	Not used		Not used			
6	Not used		Not used			
7	Not used		Not used			
8	Not used		Not used			
9	Not used		Not used			
10	Not used		Not used			
11	Not used		Not used			
12	Not used		Not used			
13	Not used		Not used			
14	Not used		Not used			
15	Not used		Not used			
16	Not used		Not used			
17	AO16+	YE-BU	AO16-	GN-BU		
18	AO15+	YE-PK	AO15-	PK-GN		
19	AO14+	YE-GY	AO14-	GY-GN		
20	AO13+	BN-BK	AO13-	WH-BK		
21	AO12+	BN-RD	AO12-	WH-RD		
22	AO11+	BN-BU	AO11-	WH-BU		
23	AO10+	PK-BN	AO10-	WH-PK		
24	AO9+	GY-BN	AO9-	WH-GY		
25	AO8+	YE-BN	AO8-	WH-YE		
26	AO7+	BN-GN	AO7-	WH-GN		
27	AO6+	RD-BU	AO6-	GY-PK		
28	AO5+	VT	AO5-	BK		
29	AO4+	RD	AO4-	BU		
30	AO3+	PK	AO3-	GY		
31	AO2+	YE	AO2-	GN		
32	AO1+	BN	AO1-	WH		

Table 15: Pin Assignment for Mono Connector Boards with Cable Plug

3.6.8 Pin Assignment for Redundant Connector Boards with Cable Plug

HIMA provides ready-made system cables for use with this connector board, see Chapter 3.7. The cable plug and the connector boards are coded.

Lead marking based on DIN 47100:

Row	c		b		a	
	Signal	Color	Signal	Color	Signal	Color
1	Not used		Not used		U1-D1A	YE-BK
2	Not used		Not used		U1-D1B	GN-BK
3	Not used		Not used		U1-D2A	YE-RD
4	Not used		Not used		U1-D2B	GN-RD
5	Not used		Not used			
6	Not used		Not used			
7	Not used		Not used			
8	Not used		Not used			
9	Not used		Not used			
10	Not used		Not used			
11	Not used		Not used			
12	Not used		Not used			
13	Not used		Not used			
14	Not used		Not used			
15	Not used		Not used			
16	Not used		Not used			
17	Not used		Not used			
18	AO15+	YE-PK	AO15-	PK-GN		
19	Not used		Not used			
20	AO13+	BN-BK	AO13-	WH-BK		
21	Not used		Not used			
22	AO11+	BN-BU	AO11-	WH-BU		
23	Not used		Not used			
24	AO9+	GY-BN	AO9-	WH-GY		
25	Not used		Not used			
26	AO7+	BN-GN	AO7-	WH-GN		
27	Not used		Not used			
28	AO5+	VT	AO5-	BK		
29	Not used		Not used			
30	AO3+	PK	AO3-	GY		
31	Not used		Not used			
32	AO1+	BN	AO1-	WH		

Table 16: Pin Assignment for Redundant Connector Boards with Cable Plug

3.7 System Cable X-CA 011

The X-CA 011 system cable is used to wire the X-CB 014 03/04 connector board with the field zone via field termination assemblies.

General	
Cable	LIYCY-TP 18 x 2 x 0.25 mm ²
Wire	Finely stranded
Average outer diameter (d)	approx. 12.7 mm
Minimum bending radius	
Fixed laying	5 x d
Flexible application	10 x d
Combustion behavior	Flame resistant and self-extinguishing in accordance with IEC 60332-1-2, -2-2
Length	8...30 m
Color coding	Based on DIN 47100, see Table 15.

Table 17: Cable Data

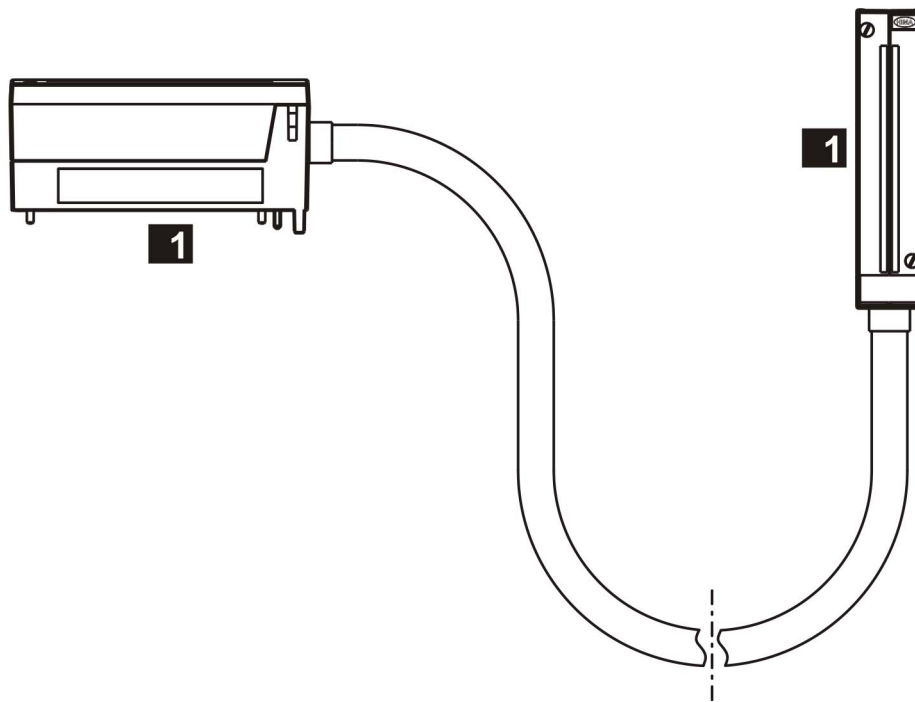

1 Identical Cable Plugs

Figure 8: System Cable X-CA 011 01 n

The system cable is available in the following standard variants:

System cable	Description	Length
X-CA 011 01 8	Coded cable plugs on both sides	8 m
X-CA 011 01 15		15 m
X-CA 011 01 30		30 m

Table 18: Available System Cables

3.7.1 Cable Plug Coding

The cable plugs are equipped with three coding pins. Cable plugs only match connector boards and FTAs with the corresponding recesses.