

HIMatrix

Safety-Related Controller

CPU 01 Manual

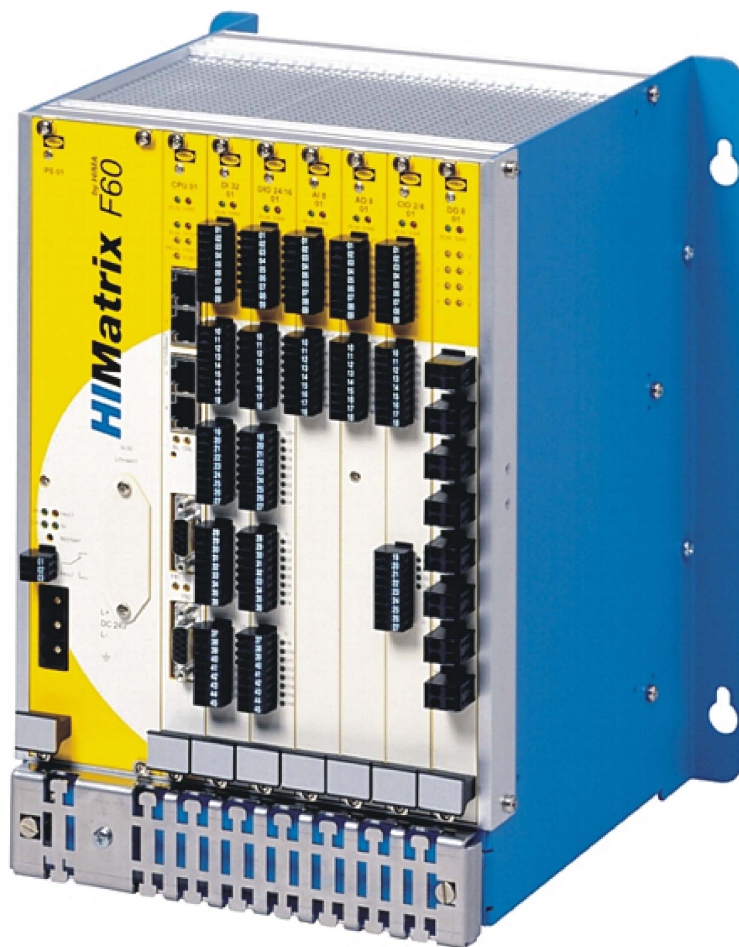

HIMA Paul Hildebrandt GmbH + Co KG
Industrial Automation

All HIMA products mentioned in this manual are protected by the HIMA trade-mark. Unless noted otherwise, this also applies to other manufacturers and their respective products referred to herein.

HIMax[®], HIMatrix[®], SILworX[®], XMR[®] and FlexSILon[®] are registered trademarks of HIMA Paul Hildebrandt GmbH + Co KG.

All of the instructions and technical specifications in this manual have been written with great care and effective quality assurance measures have been implemented to ensure their validity. For questions, please contact HIMA directly. HIMA appreciates any suggestion on which information should be included in the manual.

Equipment subject to change without notice. HIMA also reserves the right to modify the written material without prior notice.

For further information, refer to the HIMA DVD and our website at <http://www.hima.de> and <http://www.hima.com>.

© Copyright 2013, HIMA Paul Hildebrandt GmbH + Co KG

All rights reserved

Contact

HIMA contact details:

HIMA Paul Hildebrandt GmbH + Co KG

P.O. Box 1261

68777 Brühl, Germany

Phone: +49 6202 709-0

Fax: +49 6202 709-107

E-mail: info@hima.com

Revision index	Revisions	Type of change	
		technical	editorial
1.00	Added: Configuration with SILworX	X	X
1.01	Deleted: Chapter <i>Monitoring the Temperature State</i> integrated in the system manual		X
2.00	Revised: Chapter 3.4.3 Added: SIL 4 certified according to EN 50126, EN 50128 and EN 50129	X	X

Table of Contents

1	Introduction	5
1.1	Structure and Use of this Manual	5
1.2	Target Audience	6
1.3	Formatting Conventions	7
1.3.1	Safety Notes	7
1.3.2	Operating Tips	8
2	Safety	9
2.1	Intended Use	9
2.1.1	Environmental Requirements	9
2.1.2	ESD Protective Measures	9
2.2	Residual Risk	10
2.3	Safety Precautions	10
2.4	Emergency Information	10
3	Product Description	11
3.1	Safety Function	11
3.2	Equipment, Scope of Delivery	11
3.2.1	IP Address and System ID (SRS)	11
3.3	Type Label	12
3.4	Structure	13
3.4.1	Block Diagram	13
3.4.2	Front View	14
3.4.3	LED Indicators	15
3.4.3.1	System LEDs	16
3.4.3.2	Program LEDs	17
3.4.3.3	Communication LEDs	19
3.4.3.4	Fieldbus LEDs	19
3.4.4	Operating System	20
3.4.5	User Program	20
3.4.6	Communication	20
3.4.6.1	Connections for Ethernet Communication	20
3.4.6.2	Network Ports Used for Ethernet Communication	21
3.4.6.3	Connections for Fieldbus Communication	21
3.4.7	Reset Key	21
3.4.8	Monitoring the Operating Voltage	22
3.5	Product Data	23
3.6	Certified HIMatrix F60 CPU 01	23
4	Start-up	24
4.1	Installation and Mounting	24
4.1.1	Mounting and Removing the Modules	24
4.1.2	Mounting the CPU 01 in Zone 2	25

4.2	Configuration	26
4.2.1	Module Slots	26
4.3	Configuration with SILworX	27
4.4	Configuration with ELOP II Factory	27
5	Operation	28
5.1	Handling	28
5.2	Diagnosis	28
6	Maintenance	29
6.1	Faults	29
6.2	Maintenance Measures	29
6.2.1	Loading the Operating System	29
6.2.2	Proof Test	30
7	Decommissioning	31
8	Transport	32
9	Disposal	33
	Appendix	35
	Glossary	35
	Index of Figures	36
	Index of Tables	37
	Index	38

1 Introduction

This manual describes the technical characteristics of the module and its use. It provides information on how to install, start up and configure the module.

1.1 Structure and Use of this Manual

The content of this manual is part of the hardware description of the HIMatrix programmable electronic system.

This manual is organized in the following main chapters:

- Introduction
- Safety
- Product Description
- Start-up
- Operation
- Maintenance
- Decommissioning
- Transport
- Disposal

The HIMatrix F60 is available for the programming tools SILworX and ELOP II Factory. Which programming tool can be used, depends on the processor operating system of the HIMatrix F60, refer to the following table:

Programming tool	Processor operating system	Communication operating system
SILworX	CPU OS V7 and higher	COM OS V12 and higher
ELOP II Factory	CPU OS up to V6.x	COM OS up to V11.x

Table 1: Programming Tools for HIMatrix F60

In the manual, the differences are specified by using:

- Separated chapters
- Tables differentiating among the versions



Projects created with ELOP II Factory cannot be edited with SILworX, and vice versa!



The manual usually refers to the plug-in cards of the modular controller F60 as *modules*. *Modules* is also the term used in SILworX.

Additionally, the following documents must be taken into account:

Name	Content	Document number
HIMatrix System Manual Compact Systems	Hardware description of the HIMatrix compact systems	HI 800 141 E
HIMatrix System Manual Modular System F60	Hardware description of the HIMatrix modular system	HI 800 191 E
HIMatrix Safety Manual	Safety functions of the HIMatrix system	HI 800 023 E
HIMatrix Safety Manual for Railway Applications	Safety functions of the HIMatrix system using the HIMatrix in railway applications	HI 800 437 E
SILworX Communication Manual	Description of the communication protocols, ComUserTask and their configuration in SILworX	HI 801 101 E
HIMatrix PROFIBUS DP Master/Slave Manual	Description of the PROFIBUS protocol and its configuration in ELOP II Factory	HI 800 009 E
HIMatrix Modbus Master/Slave Manual	Description of the Modbus protocol and its configuration in ELOP II Factory	HI 800 003 E
HIMatrix TCP S/R Manual	Description of the TCP S/R protocol and its configuration in ELOP II Factory	HI 800 117 E
HIMatrix ComUserTask (CUT) Manual	Description of the ComUserTask and its configuration in ELOP II Factory	HI 800 329 E
SILworX Online Help	Instructions on how to use SILworX	-
ELOP II Factory Online Help	Instructions on how to use ELOP II Factory, Ethernet IP protocol	-
SILworX First Steps	Introduction to SILworX using the HIMax system as an example	HI 801 103 E
ELOP II Factory First Steps	Introduction to ELOP II Factory	HI 800 006 E

Table 2: Additional Relevant Documents

The latest manuals can be downloaded from the HIMA website at www.hima.com. The revision index on the footer can be used to compare the current version of existing manuals with the Internet edition.

1.2 Target Audience

This document addresses system planners, configuration engineers, programmers of automation devices and personnel authorized to implement, operate and maintain the modules and systems. Specialized knowledge of safety-related automation systems is required.

1.3 Formatting Conventions

To ensure improved readability and comprehensibility, the following fonts are used in this document:

Bold	To highlight important parts. Names of buttons, menu functions and tabs that can be clicked and used in the programming tool.
<i>Italics</i>	For parameters and system variables
Courier	Literal user inputs
RUN	Operating state are designated by capitals
Chapter 1.2.3	Cross references are hyperlinks even though they are not particularly marked. When the cursor hovers over a hyperlink, it changes its shape. Click the hyperlink to jump to the corresponding position.

Safety notes and operating tips are particularly marked.

1.3.1 Safety Notes

The safety notes are represented as described below.

These notes must absolutely be observed to reduce the risk to a minimum. The content is structured as follows:

- Signal word: warning, caution, notice
- Type and source of risk
- Consequences arising from non-observance
- Risk prevention

SIGNAL WORD



Type and source of risk!
Consequences arising from non-observance
Risk prevention

The signal words have the following meanings:

- Warning indicates hazardous situation which, if not avoided, could result in death or serious injury.
- Caution indicates hazardous situation which, if not avoided, could result in minor or modest injury.
- Notice indicates a hazardous situation which, if not avoided, could result in property damage.

NOTE



Type and source of damage!
Damage prevention

1.3.2 Operating Tips

Additional information is structured as presented in the following example:

i The text corresponding to the additional information is located here.

Useful tips and tricks appear as follows:

TIP The tip text is located here.

2 Safety

All safety information, notes and instructions specified in this document must be strictly observed. The product may only be used if all guidelines and safety instructions are adhered to.

This product is operated with SELV or PELV. No imminent risk results from the product itself. The use in Ex-zone is permitted if additional measures are taken.

2.1 Intended Use

HIMatrix components are designed for assembling safety-related controller systems.

When using the components in the HIMatrix system, comply with the following general requirements.

2.1.1 Environmental Requirements

Requirement type	Range of values ¹⁾
Protection class	Protection class III in accordance with IEC/EN 61131-2
Ambient temperature	0...+60 °C
Storage temperature	-40...+85 °C
Pollution	Pollution degree II in accordance with IEC/EN 61131-2
Altitude	< 2000 m
Housing	Standard: IP20
Supply voltage	24 VDC
¹⁾ The values specified in the technical data apply and are decisive for devices with extended environmental requirements.	

Table 3: Environmental Requirements

Exposing the HIMatrix system to environmental conditions other than those specified in this manual can cause the HIMatrix system to malfunction.

2.1.2 ESD Protective Measures

Only personnel with knowledge of ESD protective measures may modify or extend the system or replace devices.

NOTE



Device damage due to electrostatic discharge!

- When performing the work, make sure that the workspace is free of static, and wear an ESD wrist strap.
- If not used, ensure that the device is protected from electrostatic discharge, e.g., by storing it in its packaging.

2.2 Residual Risk

No imminent risk results from a HIMatrix system itself.

Residual risk may result from:

- Faults related to engineering
- Faults related to the user program
- Faults related to the wiring

2.3 Safety Precautions

Observe all local safety requirements and use the protective equipment required on site.

2.4 Emergency Information

A HIMatrix system is a part of the safety equipment of a site. If a device or a module fails, the system enters the safe state.

In case of emergency, no action that may prevent the HIMatrix systems from operating safely is permitted.

3 Product Description

The **CPU 01** module is the central component of the HIMatrix F60 controller.

The module can only be inserted in the slot located on the right, next to the power supply module of the HIMatrix F60 subrack. It is used to store the operating system and the user program, and executes all central functions, including communication with the PADT and other systems. It monitors the operating voltage and operating temperature.

The module has been certified by the TÜV for safety-related applications up to SIL 3 (IEC 61508, IEC 61511 and IEC 62061), Cat. 4 and PL e (EN ISO 13849-1) and SIL 4 (EN 50126, EN 50128 and EN 129).

Further safety standards, application standards and test standards are specified in the certificates available on the HIMA website.

Module's faults are signaled by the *ERR* LED located on the front plate, see Chapter 3.4.3.

3.1 Safety Function

The CPU monitors the sequence and the proper, logical execution of the operating system and user program. The following functions are time monitored:

- CPU hardware and software self-tests
- CPU RUN cycle (including the user program)
- I/O tests and processing of I/O signals

For further information on the fault reaction of the processor module, refer to Chapter 6.1.

3.2 Equipment, Scope of Delivery

The following table specifies the available controller variants:

Designation	Description
CPU 01	Central module, for ELOP II Factory programming tool
CPU 01 SILworX	Processor module, for SILworX programming tool

Table 4: Available Variants

3.2.1 IP Address and System ID (SRS)

A transparent label is delivered with the device to allow one to note the IP address and the system ID (SRS for system rack slot) after a change.

IP ____ . ____ . ____ . ____ SRS ____ . ____ . ____

Default value for IP address: 192.168.0.99

Default value for SRS: 60 000.0.0

The label must be affixed such that the ventilation slots in the housing are not obstructed.

Refer to the First Steps manual of the programming tool for more information on how to modify the IP address and the system ID.

3.3 Type Label

The type plate contains the following details:

- Product name
- Bar code (1D or 2D code)
- Part no.
- Production year
- Hardware revision index (HW Rev.)
- Firmware revision index (FW Rev.)
- Operating voltage
- Mark of conformity

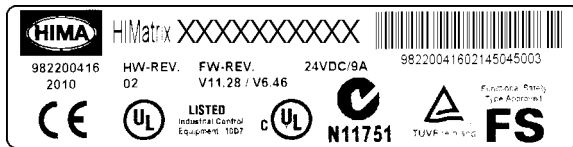

Figure 1: Sample Type Label

3.4 Structure

This chapter describes the layout and function of the module, and its communication via safeEthernet.

3.4.1 Block Diagram

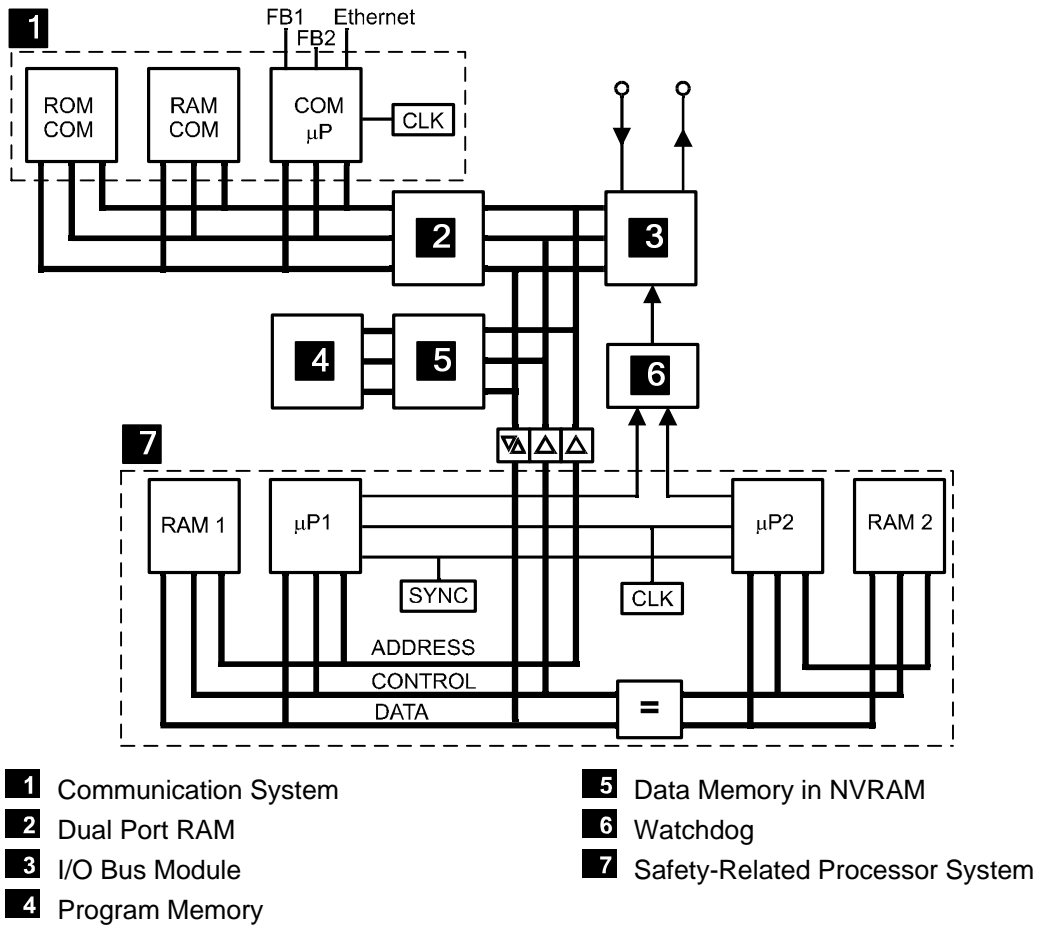

Figure 2: Block Diagram

3.4.2 Front View

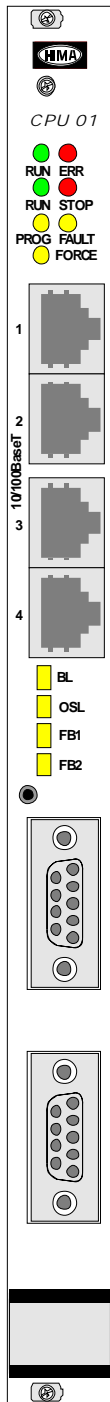

Figure 3: Front View CPU 01

3.4.3 LED Indicators

The LEDs indicate the operating state of the module. The LEDs are classified as follows:

- System LEDs
- Program LEDs
- Communication LEDs
- Fieldbus LEDs

Function and meaning of the system LEDs, the program LEDs and the communication LEDs depend on the CPU operating system (and thus on the COM operating system).

When the supply voltage is switched on, a LED test is performed and all LEDs are briefly lit.

Definition of Blinking Frequencies

The following table defines the blinking frequencies of the LEDs:

Name	Blinking frequencies
Blinking	Non-specified blinking, with CPU OS up to V7.x
Blinking1	Long (approx. 600 ms) on, long (approx. 600 ms) off, with CPU OS V8 and higher
Blinking-x	Ethernet communication: Blinking synchronously with data transfer, with CPU OS V8 and higher

Table 5: Blinking Frequencies of LEDs

3.4.3.1 System LEDs

System LEDs with CPU OS V8 and Higher

While the controller is being booted, all LEDs are lit simultaneously.

LED	Color	Status	Description
Run	Green	On	Controller in STOP or RUN, normal operation
		Blinking1	A new operating system is being loaded.
		Off	The controller is not in the RUN state.
ERR	Red	On	Missing license for additional functions (communication protocols, reload), test mode.
		Blinking1	<ul style="list-style-type: none"> ▪ The controller is in the ERROR STOP state. Internal system faults detected by self-tests, e.g., hardware fault or voltage supply. The processor system can only be restarted with a command from the PADT (reboot). ▪ System configuration fault. ▪ Fault while loading the operating system.
		Off	No faults detected

Table 6: System LEDs with CPU OS V8 and Higher

System LEDs with CPU OS up to V6

While the controller is being booted, all LEDs are lit simultaneously.

LED	Color	Status	Description
RUN	Green	On	Module in STOP or RUN, normal operation
		Blinking	A new operating system is being loaded.
		Off	The controller is not in the RUN state.
ERR	Red	On	<ul style="list-style-type: none"> ▪ The controller is in the ERROR STOP state. Internal system faults detected by self-tests, e.g., hardware fault or cycle time overrun. The processor system can only be restarted with a command from the PADT (reboot). ▪ System configuration fault.
		Blinking	If ERROR blinks and all others LEDs are lit simultaneously, the boot loader has detected an operating system fault in the flash memory and waits for a new operating system to be loaded.
		Off	No faults detected.

Table 7: System LEDs with CPU OS up to V6

3.4.3.2 Program LEDs

Program LEDs with CPU OS V8 and Higher

While the controller is being booted, all LEDs are lit simultaneously.

LED	Color	Status	Description
RUN	Green	On	The controller is in the RUN state. The user program is in the RUN or FREEZE state.
		Blinking1	<ul style="list-style-type: none"> ▪ The controller is in the OPERATE state (only with central modules). ▪ A new operating system is being loaded.
		Off	Controller is in none of the states described.
STOP	Red	On	Controller in the STOP / VALID CONFIGURATION state
		Blinking1	<ul style="list-style-type: none"> ▪ Controller in the STOP / INVALID CONFIGURATION state ▪ A new operating system is being loaded.
		Off	Controller is in none of the states described.
PROG	Yellow	On	<ul style="list-style-type: none"> ▪ The controller is being loaded with a new configuration. ▪ A new operating system is being loaded. ▪ WDT or safety time change ▪ SRS change
		Off	None of the described events occurred.
FAULT	Yellow	Blinking1	<ul style="list-style-type: none"> ▪ The new operating system is corrupted (after OS download). ▪ Fault while loading a new operating system ▪ The loaded configuration is not valid. ▪ At least one module has detected an I/O fault.
		Off	None of the described events occurred.
FORCE	Yellow	On	Forcing prepared: The force switch is set for a variable, the force main switch is still deactivated. The module is in the RUN or STOP state.
		Blinking1	Forcing is active: At least one local or global variable has adopted the corresponding force value.
		Off	Forcing is not activated.
OSL	Yellow	Blinking1	Operating system emergency loader active.
		Off	Operating system emergency loader inactive.
BL	Yellow	Blinking1	<ul style="list-style-type: none"> ▪ OS and OSL binary defective or INIT_FAIL hardware fault. ▪ Fault in the external process data communication.
		Off	None of the described events occurred.

Table 8: Program LEDs with CPU OS V8 and Higher

Program LEDs with CPU OS up to V6.x

While the controller is being booted, all LEDs are lit simultaneously.

LED	Color	Status	Description
RUN	Green	On	The controller is in the RUN state. The user program is in the RUN or FREEZE state.
		Off	The controller is not in the RUN state.
STOP	Red	On	The controller is in STOP.
		Off	The controller is in RUN or a new operating system is being loaded.
PROG	Yellow	On	The controller is being loaded with a new configuration.
		Blinking	The controller switches from INIT to STOP A new operating system is being loaded into the flash ROM.
		Off	No configuration or operating system is being loaded.
FAULT	Yellow	On	The loaded configuration is not valid. The new operating system is corrupted (after OS download).
		Blinking	Fault while loading a new operating system One or multiple I/O faults occurred.
		Off	None of the described faults occurred.
FORCE	Yellow	On	The controller is in RUN, and forcing was activated.
		Blinking	The PES is in STOP, but forcing has been prepared and is activated when the PES is started.
		Off	Forcing is not activated.
OSL	Yellow	Blinking	Operating system emergency loader active.
		Off	Operating system emergency loader inactive.
BL	Yellow	Blinking	OS and OSL binary defective or hardware fault, INIT_FAIL.
		Off	None of the described faults occurred.

Table 9: Program LEDs with CPU OS up to V6.x

3.4.3.3 Communication LEDs

All RJ-45 connectors are provided with a small green and a yellow LEDs.

Communication LEDs with CPU OS V8 and Higher

The LEDs signal the following states:

LED	Status	Description
Green	On	Full duplex operation
	Blinking1	IP address conflict, all communication LEDs are blinking
	Blinking-x	Collision
	Off	Half duplex operation, no collision
Yellow	On	Connection available
	Blinking1	IP address conflict, all communication LEDs are blinking
	Blinking-x	Interface activity
	Off	No connection available

Table 10: Ethernet Indicators with CPU OS V8 and Higher

Communication LEDs up to CPU OS V6.x

The LEDs signal the following states:

LED	Status	Description
Green	On	Full duplex operation
	Blinking	Collision
	Off	Half duplex operation, no collision
Yellow	On	Connection available
	Blinking	Interface activity
	Off	No connection available

Table 11: Ethernet Indicators up to CPU OS V6.x

3.4.3.4 Fieldbus LEDs

Additionally, D-sub connectors and two corresponding LEDs are available for indicating non safe communication via fieldbuses:

LED	Color	Status	Description
FB1	Yellow	On	RS485, fieldbus 1 is active
		Blinking	FB1 and FB2 blink simultaneously: Emergency loader is active
FB2	Yellow	On	RS485, fieldbus 2 is active
		Blinking	FB1 and FB2 blink simultaneously: Emergency loader is active

Table 12: Indicators for Fieldbus Communication

3.4.4 Operating System

The operating system loaded into the CPU contains all basic functions of the HIMatrix programmable electronic system (PES), for example:

- Reading the inputs and writing to the outputs
- Processing the user program
- Performing all test routines for hardware and software
- Cycle time monitoring (watchdog)
- Communication with other systems

For a description of the operating system functions and the variables used to configure the systems and all modules, refer to the HIMatrix System Manual (HI 800 191 E) for the Modular F60 System.

3.4.5 User Program

The user program is created using one programming tool, SILworX or ELOP II Factory. It is then translated into a machine code using the code generator and transferred to the flash EPROM of central module.

3.4.6 Communication

The Ethernet interfaces and fieldbus interfaces of the CPU 01 module are used to communicate with external systems. Each individual Ethernet interface can simultaneously process multiple protocols.



When configuring safety-related communication, observe the instructions specified in the Communication Manual (for SILworX) or the Safety Manual (ELOP II Factory).

3.4.6.1 Connections for Ethernet Communication

Property	Description
Ports	4
Transfer standard	10BASE-T/100BASE-Tx, half and full duplex
Auto negotiation	Yes
Auto crossover	Yes
Connection socket	RJ-45
IP address	Freely configurable ¹⁾
Subnet mask	Freely configurable ¹⁾
Supported protocols	<ul style="list-style-type: none"> ▪ Safety-related: safeethernet ▪ Standard protocols: Programming and debugging tool (PADT), OPC, Modbus TCP, TCP SR, SNTP. Ethernet/IP (with CPU OS versions up to 6.x only)
¹⁾ The general rules for assigning IP address and subnet masks must be adhered to.	

Table 13: Connections for Fieldbus Communication

The four RJ-45 connectors with integrated LEDs are located on the front plate of the module. Refer to Chapter 3.4.3.3 for a description of the LEDs' function.

The connection parameters are read based on the MAC address (media access control address) defined during manufacturing.

The MAC address of the module is specified on the label on the rear side of the printed circuit board. The first MAC address applies for the COM module on the central module, the second for the switch.

Examples of label: MAC ADR1: 00.E0.A1.00.0E.04 (COM)
 MAC ADR2: 00.E0.A1.00.0E.05 (switch)

3.4.6.2 Network Ports Used for Ethernet Communication

UDP ports	Use
8000	Programming and operation with the programming tool
8001	Configuration of the remote I/O using the PES (ELOP II Factory)
8004	Configuration of the remote I/O using the PES (SILworX)
6010	safe ethernet and OPC
123	SNTP (time synchronization between PES and remote I/O, PES and external devices)
6005 / 6012	If TCS_DIRECT was not selected in the HH network
502	Modbus (can be modified by the user)
44 818	EtherNet/IP session protocol for device identification
2222	EtherNet/IP Data Exchange

Table 14: Network Ports (UDP Ports) in Use

TCP ports	Use
502	Modbus (can be modified by the user)
xxx	TCP SR assigned by the user
44 818	EtherNet/IP Explicit Messaging Services

Table 15: Network Ports (TCP Ports) in Use

3.4.6.3 Connections for Fieldbus Communication

The two 9-pole D-sub connectors can be accessed through the front plate of the module.

The fieldbus interfaces FB1 and FB2 can be equipped with fieldbus submodules. The fieldbus submodules are optional and must be mounted by the manufacturer. The available fieldbus submodules are described in the SILworX communication manual (HI 801 101 E).

The fieldbus interfaces are not operational without fieldbus submodule.

3.4.7 Reset Key

The device is equipped with a reset key. The key is only required if the user name or password for administrator access is not known. If only the set device IP address does not match the PADT (PC), the connection can be established with a `Route add` entry on the PC.

The key can be accessed through a small round hole located on the front plate. The key is engaged using a suitable pin made of insulating material to avoid short-circuits within the device.

The reset is only effective if the device is rebooted (switched off and on) while the key is simultaneously engaged for at least 20 s. Engaging the key during operation has no effect.

⚠ CAUTION**Fieldbus communication may be disturbed!**

Prior to switching on the device with the reset key engaged, all device fieldbus connectors must be unplugged to ensure that the fieldbus communication among other stations is not disturbed.

The fieldbus plugs may only be plugged in again when the device is in the RUN or STOP state.

Properties and behavior of the device after a reboot with engaged reset key:

- Connection parameters (IP address and system ID) are set to the default values.
- All accounts are deactivated except for the default account administrator with empty password.
- With COM operating system version 10.42 and higher, loading a user program or operating system with default connection parameters is inhibited!
The loading procedure is only allowed after the connection parameters and the account have been configured on the device and the device has been rebooted.

After a new reboot without the reset key engaged, the connection parameters (IP address and system ID) and accounts become effective.

- Those configured by the user.
- Those valid prior to rebooting with the reset key engaged, if no changes were performed.

3.4.8 Monitoring the Operating Voltage

The CPU 01 central module monitors the 24 VDC operating voltage of the HIMatrix F60; reactions occur in accordance with the listed levels:

Voltage level	Reaction of the CPU
18...28.8 V	No reaction
< 18.0 V	Alarm state (the internal variables are written to)
< 13.0 V	Shutdown

Table 16: Operating Voltage Monitoring

The alarm can be evaluated with a PADT loaded with a programming tool, using the *Power Supply State* system parameter.

3.5 Product Data

General	
User memory	Versions up to 6.46 max. 500 kB user program max. 500 kB user data Version 6.100 max. 2047 kB user program max. 2047 kB user data Version 7 and higher max. 1023 kB user program max. 1023 kB user data
Response time	≥ 20 ms
Ethernet interfaces	4 x RJ-45, 10BASE-T/100BASE-Tx with integrated switch
Fieldbus interfaces	2 x 9-pole D-sub FB1 and FB2 with fieldbus submodule pluggable
Operating voltage	24 VDC, -15...+20 %, $r_{PP} \leq 15\%$, from a power supply unit with safe insulation in accordance with IEC 61131-2
Operating data	3.3 VDC / 1.5 A 5 VDC / 0.1 A
Buffer for date/time	Gold capacitor
Ambient temperature	0...+60 °C
Storage temperature	-40...+85 °C
Space requirement	6 RU, 4 HP
Weight	280 g

Table 17: Product Data

3.6 Certified HIMatrix F60 CPU 01

HIMatrix F60 CPU 01	
CE	EMC, ATEX Zone 2
TÜV	IEC 61508 1-7:2000 up to SIL 3 IEC 61511:2004 EN ISO 13849-1:2008 up to Cat. 4 und PL e
TÜV ATEX	94/9/EG EN 1127-1 EN 61508
UL Underwriters Laboratories Inc.	ANSI/UL 508, NFPA 70 – Industrial Control Equipment CSA C22.2 No.142 UL 1998 Software Programmable Components NFPA 79 Electrical Standard for Industrial Machinery IEC 61508
FM Approvals	Class I, DIV 2, Groups A, B, C and D Class 3600, 1998 Class 3611, 1999 Class 3810, 1989 Including Supplement #1, 1995 CSA C22.2 No. 142 CSA C22.2 No. 213
PROFIBUS Nutzerorganisation (PNO)	Test Specification for PROFIBUS DP Slave, Version 3.0 November 2005
TÜV CENELEC	Railway applications EN 50126: 1999 up to SIL 4 EN 50129: 2001 up to SIL 4 EN 50129: 2003 up to SIL 4

Table 18: Certificates