

ControlLogix I/O Modules Specifications

Bulletin 1756

Topic	Page
Summary of Changes	1
I/O Module Overview	3
AC Digital I/O Modules	7
DC Digital I/O Modules	45
Safety I/O Modules	147
Contact I/O Modules	163
Analog I/O Modules	169
HART I/O Modules	217
Compute Modules	241
Specialty I/O Modules	245
ControlLogix I/O Accessories	269

The ControlLogix® Architecture provides a wide range of input and output modules to span many applications, from high-speed digital to process control. The ControlLogix architecture uses Producer/Consumer technology, which allows input information and output status to be shared among multiple ControlLogix controllers.

Summary of Changes

This publication contains new and updated information as indicated in the following table.

Topic	Page
Corrected 1756-0F8H, 1756-0F8HK Technical Specifications	233
Corrected RTB Specifications	270

Rockwell Automation recognizes that some of the terms that are currently used in our industry and in this publication are not in alignment with the movement toward inclusive language in technology. We are proactively collaborating with industry peers to find alternatives to such terms and making changes to our products and content. Please excuse the use of such terms in our content while we implement these changes.

Bulletin 1756 ControlLogix chassis-based modules provide a full range of digital, diagnostic digital, analog, motion control, specialty I/O, and compute modules to meet your application needs. You can use any of the chassis-based modules in the local chassis of a ControlLogix controller or in a chassis linked to a ControlLogix controller across ControlNet[®] or EtherNet/IP[™] networks.

Catalog Number Explanation

Certain I/O module catalog numbers contain characters at the **end** of the catalog number that indicate additional features.

Character	I/O Type	Description
D	Diagnostic	These modules provide diagnostic features to the point level.
E	Electronic fusing	These modules have internal electronic fusing to help prevent too much current from flowing through the module.
I	Individually isolated	These modules have individually isolated inputs or outputs.
K	Conformal coated	These modules have additional conformal coating and design considerations that add a degree of protection when exposed to harsh, corrosive environments.
XT	Conformal coated	These modules have additional conformal coating and design considerations that add a greater degree of protection when exposed to harsh, corrosive environments.
H	HART interface	These modules send and receive digital information across analog wires between smart devices and control or monitoring systems data using HART (Highway Addressable Remote Transducer) protocol.
S	Scheduled or Safety	These modules offer time-scheduled output control or ensure that ControlLogix control systems operate safely.
SOE	Sequence of Events	These modules offer sub-millisecond time-stamping on a per point basis.

IMPORTANT

When a ControlLogix product that is rated for harsh environments (corrosive atmosphere, extended temperature, etc.) is used in a system with other ControlLogix products that have lower specification values, the system is derated to the lowest common value.

EXAMPLE: If the maximum operating temperature specification found in the Technical Data for your ControlLogix-XT module is 70 °C (158 °F) and you pair it with a ControlLogix chassis that is temperature rated to 60 °C (140 °F), your system is derated to 60 °C (140 °F).

To ensure that your system is equipped for harsh environments, compare the corrosive atmosphere, temperature, and other specifications found in the Technical Data publication for each product.

Available 1756 I/O Modules

Module Type	Input Module Catalog Number	Page	Output Module Catalog Number	Page	
AC Digital I/O Modules	1756-IA8D, 1756-IA8DK	7	1756-OA8, 1756-OA8K	26	
	1756-IA16, 1756-IA16K	10	1756-OA8D	29	
	1756-IA16I, 1756-IA16IK	13	1756-OA8E	32	
	1756-IA32, 1756-IA32K	16	1756-OA16, 1756-OA16K	35	
	1756-IM16I, 1756-IM16IK	19	1756-OA16I, 1756-OA16IK	38	
	1756-IN16, 1756-IN16K	22	1756-ON8, 1756-ON8K	41	
DC Digital I/O Modules	1756-IB16, 1756-IB16K, 1756-IB16XT	45	1756-OB8, 1756-OB8K	90	
	1756-IB16D, 1756-IB16DK	49	1756-OB8E1, 1756-OB8E1K	94	
	1756-IB16I, 1756-IB16IK	53	1756-OB16D, 1756-OB16DK	98	
	1756-IB16IF, 1756-IB16IFK	57	1756-OB16E, 1756-OB16EK	102	
	1756-IB16ISOE, 1756-IB16ISOEK	61	1756-OB16I, 1756-OB16IK	107	
	1756-IB32, 1756-IB32K, 1756-IB32XT	65	1756-OB16IEF, 1756-OB16IEFK	111	
	1756-IC16	68	1756-OB16IEFS, 1756-OB16IEFSK	115	
	1756-IG16, 1756-IG16K	72	1756-OB16IS	119	
	1756-IH16I, 1756-IH16IK	76	1756-OB32, 1756-OB32K, 1756-OB32XT	123	
	1756-IH16ISOE, 1756-IH16ISOEK	79	1756-OC8, 1756-OC8K	127	
	1756-IV16, 1756-IV16K	82	1756-OG16, 1756-OG16K	131	
	1756-IV32, 1756-IV32K	86	1756-OH8I	135	
				1756-OV16E	138
				1756-OV32E, 1756-OV32EK	142
Safety I/O Modules	1756-IB16S	147	1756-OBV8S	154	
Contact I/O Modules			1756-OX8I, 1756-OX8IK	163	
			1756-OW16I, 1756-OW16IK	166	
Analog I/O Modules	1756-IF4FXOF2F, 1756-IF4FXOF2FK	169	1756-OF4, 1756-OF4K	204	
	1756-IF8, 1756-IF8K	174	1756-OF8, 1756-OF8K	208	
	1756-IF8I, 1756-IF8IK	179	1756-OF8I, 1756-OF8IK	212	
	1756-IF16, 1756-IF16K	184			
	1756-IRT8I, 1756-IRT8IK	189			
	1756-IR12, 1756-IR12K	195			
	1756-IT16, 1756-IT16K	199			
HART I/O Modules	1756-IF8H, 1756-IF8HK	217	1756-OF8H, 1756-OF8HK	233	
	1756-IF8IH, 1756-IF8IHK	221	1756-OF8IH, 1756-OF8IHK	237	
	1756-IF16H, 1756-IF16HK	225			
	1756-IF16IH, 1756-IF16IHK	229			
Compute Modules	1756-CMEE1Y1	241			
	1756-CMS1B1, 1756-CMS1C1, 1756-CMS1D1, 1756-CMS1H1	243			
Specialty I/O Modules	1756-CFM, 1756-CFMK	245	1756-LSC8XIB8I, 1756-LSC8XIB8IK	258	
	1756-HSC, 1756-HSCK	252	1756-PLS	263	

1756-0A8D

ControlLogix 120V AC diagnostic output module

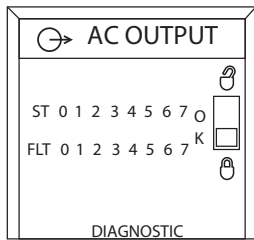
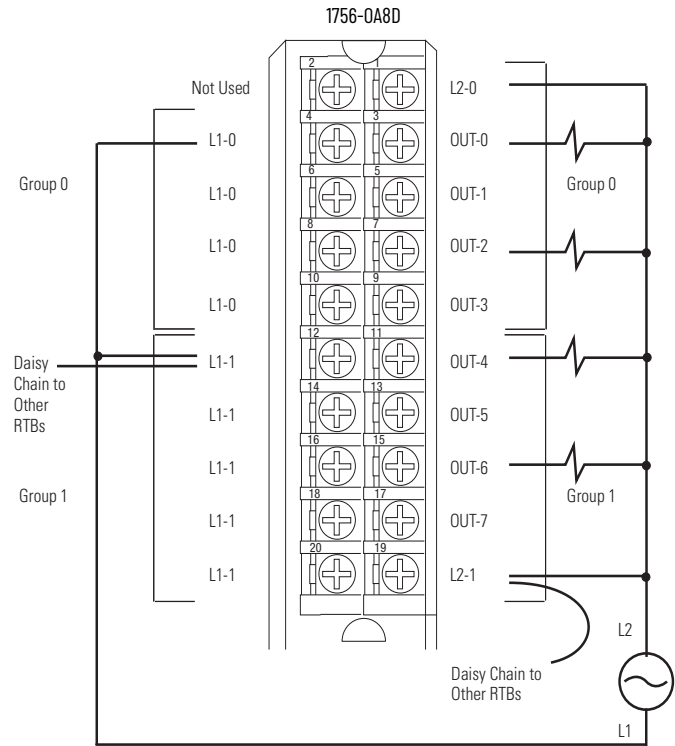
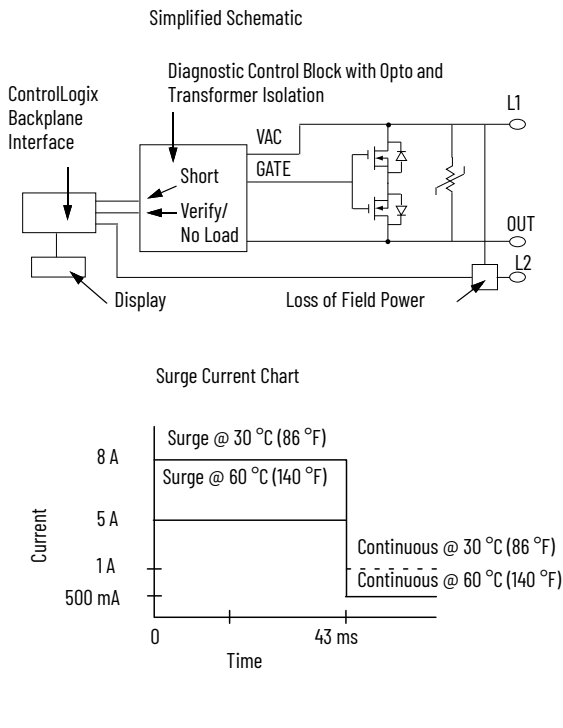

Diagnostic Specifications

Attribute	1756-0A8D
Short trip, min	12 A for 500 μ s
No load	Off-state detection only
Output verification	On-state detection only
Pulse test	Configurable maximum width and max time delay from zero cross
Field power loss (zero cross)	Detects at 25V peak min (firmware phase locked loop)
Time stamp of diagnostics	\pm 1 ms

Technical Specifications

Attribute	1756-0A8D
Outputs	8 diagnostic, electronic fusing (4 points/group)
Voltage category	120V AC 50/60 Hz
Operating voltage range ⁽¹⁾	74...132V AC 47...63 Hz
Output delay time Off to On	9.3 ms @ 60 Hz 11 ms @ 50 Hz
On to Off	9.3 ms @ 60 Hz 11 ms @ 50 Hz
Current draw @ 5.1V	175 mA
Current draw @ 24V	250 mA
Total backplane power	6.89 W
Power dissipation, max	5.3 W @ 60 °C (140 °F)
Thermal dissipation	18.0 BTU/hr
Off-state leakage current, max	3 mA per point
On-state voltage drop, max	2.5V peak @ 0.5 A 3V peak @ 1 A
Current per point, max	1 A @ 30 °C (86 °F) linear derating 0.5 A @ 60 °C (140 °F) linear derating
Current per module, max	8 A @ 30 °C (86 °F) linear derating 4 A @ 60 °C (140 °F) linear derating
Surge current per point	8 A for 43 ms per point, repeatable every 2 s @ 30 °C (86 °F) 5 A for 43 ms per point, repeatable every 1 s @ 60 °C (140 °F)
Load current, min	10 mA per point
Scheduled outputs	Synchronization within 16.7 s max, reference to the Coordinated System Time
States in Fault mode per point	Hold last state, On or Off (Off is default)
States in Program mode per point	Hold last state, On or Off (Off is default)
Isolation voltage	125V (continuous), basic insulation type, outputs-to-backplane, and output group-to-group No isolation between individual group outputs
Inhibit voltage, max	Zero crossing 25V peak
Module keying	Electronic, software configurable
Fusing	Electronically fused per point
Removable terminal block	1756-TBNH 1756-TBSH
RTB keying	User-defined mechanical
Slot width	1
Wire size	1756-TBNH Single wire connection: 0.33...2.1 mm ² (22...14 AWG) solid or stranded shielded copper wire rated at 105 °C (221 °F), or greater, 1.2 mm (3/64 in.) insulation max. Double wire connection: 0.33...1.3 mm ² (22...16 AWG) solid or stranded copper wire rated at 105 °C (221 °F), or greater, 1.2 mm (3/64 in.) insulation max. 1756-TBSH Single wire connection: 0.33...2.1 mm ² (22...14 AWG) solid or stranded shielded copper wire rated at 105 °C (221 °F), or greater, 1.2 mm (3/64 in.) insulation max.
Wire category ⁽²⁾	1 - on signal ports
Enclosure type	None (open style)
North American temperature code	T4A

(1) UL certification for 120V 50/60 Hz nominal. Rockwell Automation specified to 74...132V, 47...63 Hz.

(2) Use this conductor category information for planning conductor routing as described in the system-level installation manual. See the Industrial Automation Wiring and Grounding Guidelines, publication [1770-4.1](#).

Environmental Specifications

Attribute	1756-0A8D
Temperature, operating IEC 60068-2-1 (Test Ae, Operating Cold), IEC 60068-2-2 (Test Be, Operating Dry Heat), IEC 60068-2-14 (Test Nb, Operating Thermal Shock)	0...60 °C (32...140 °F)
Temperature, nonoperating IEC 60068-2-1 (Test Ab, Unpackaged Nonoperating Cold), IEC 60068-2-2 (Test Bb, Unpackaged Nonoperating Dry Heat), IEC 60068-2-14 (Test Na, Unpackaged Nonoperating Thermal Shock)	-40...+85 °C (-40...+185 °F)
Relative humidity IEC 60068-2-30 (Test dB, Unpackaged Damp Heat)	5...95% noncondensing
Vibration IEC 60068-2-6 (Test Fc, Operating)	2 g @ 10...500 Hz
Shock, operating IEC 60068-2-27 (Test Ea, Unpackaged Shock)	30 g
Shock, nonoperating IEC 60068-2-27 (Test Ea, Unpackaged Shock)	50 g
Emissions	IEC 61000-6-4
ESD immunity IEC 61000-4-2	6 kV contact discharges 8 kV air discharges
Radiated RF immunity IEC 61000-4-3	10V/m with 1 kHz sine wave 80% AM from 80...2000 MHz 10V/m with 200 Hz 50% Pulse 100% AM @ 900 MHz 10V/m with 200 Hz 50% Pulse 100% AM @ 1890 MHz 3V/m with 1 kHz sine wave 80% AM from 2000...2700 MHz
EFT/B immunity IEC 61000-4-4	±4 kV at 5 kHz on signal ports
Surge transient immunity IEC 61000-4-5	±1 kV line-line (DM) and ±2 kV line-earth (CM) on signal ports
Conducted RF immunity IEC 61000-4-6	10V rms with 1 kHz sine wave 80% AM from 150 kHz...80 MHz

Certifications

Certification ⁽¹⁾	1756-0A8D
cULus	UL Listed Industrial Control Equipment, certified for US and Canada. See UL File E65584. UL Listed for Class I, Division 2 Group A,B,C,D Hazardous Locations, certified for U.S. and Canada. See UL File E194810.
CE	European Union 2014/30/EU EMC Directive, compliant with: <ul style="list-style-type: none"> EN 61326-1; Meas./Control/Lab., Industrial Requirements EN 61000-6-2; Industrial Immunity EN 61000-6-4; Industrial Emissions EN 61131-2; Programmable Controllers (Clause 8, Zone A & B) European Union 2014/35/EU LVD, compliant with EN 61131-2; Programmable Controllers (Clause 11)
RCM	Australian Radiocommunications Act, compliant with EN 61000-6-4; Industrial Emissions
FM	FM Approved Equipment for use in Class I Division 2 Group A,B,C,D Hazardous Locations
KC	Korean Registration of Broadcasting and Communications Equipment, compliant with Article 58-2 of Radio Waves Act, Clause 3
UKCA	In conformity with the following UK Statutory Instruments and their amendments: <ul style="list-style-type: none"> 2016 No. 1091, Electromagnetic Compatibility Regulations 2016 No. 1101, Electrical Equipment (Safety) Regulations 2016 No. 1107, Equipment and Protective Systems Intended for Use in Potentially Explosive Atmospheres Regulations 2012 No. 3032, Restriction of the Use of Certain Hazardous Substances in Electrical and Electronic Equipment
Morocco	In conformity with the following regulations: <ul style="list-style-type: none"> Arrêté ministériel n° 6404-15 du 1^{er} muharram 1437 (15 octobre 2015) Équipements électriques destinés à être utilisés sous certaines limites de tension Arrêté ministériel n° 6404-15 du 29 ramadan 1436 (16 juillet 2015) Compatibilité électromagnétique des équipements

(1) When product is marked. See the Product Certification link at rok.auto/certifications for Declarations of Conformity, Certificates, and other certification details.