

SLC 500 Digital I/O Modules

Input Catalog Numbers 1746-IA4, 1746-IA8, 1746-IA16, 1746-IB8, 1746-IB16, 1746-IC16, 1746-IG16, 1746-IH16, 1746-IM4, 1746-IM8, 1746-IM16, 1746-IN16, 1746-ITB16, 1746-ITV16, 1746-IV8, 1746-IV16

Output Catalog Numbers 1746-OA8, 1746-OA16, 1746-OAP12, 1746-OB8, 1746-OB6EI, 1746-OB16, 1746-OB16E, 1746-OBP8, 1746-OBP16, 1746-OG16, 1746-OV8, 1746-OV16, 1746-OVP16, 1746-OW4, 1746-OW8, 1746-OW16, 1746-OX8

Combination Input/Output Catalog Numbers 1746-IO4, 1746-IO8, 1746-IO12, 1746-IO12DC

Table of Contents

Topic	Page
Important User Information	2
North American Hazardous Location Approval	3
Environment and Enclosure	4
Prevent Electrostatic Discharge	4
Install and Remove the Module	5
Octal Label Kit Installation (for PLC processors only)	6
Wiring Diagrams	17
Apply the Octal Filter Label	6
Apply the Octal Door Label	6
Removable Terminal Blocks	6
Recovery From Blown Fuse/Processor Fault/Processor Shutdown	13
Replacement Fuse Recommendations	13
Replace Fuses	14
Electronically Protected Modules (1746-OB6EI and 1746-OB16E)	14
Specifications	29

Important User Information

Solid-state equipment has operational characteristics differing from those of electromechanical equipment. Safety Guidelines for the Application, Installation and Maintenance of Solid State Controls (Publication SGI-1.1 available from your local Rockwell Automation sales office or online at <http://www.rockwellautomation.com/literature/>) describes some important differences between solid-state equipment and hard-wired electromechanical devices. Because of this difference, and also because of the wide variety of uses for solid-state equipment, all persons responsible for applying this equipment must satisfy themselves that each intended application of this equipment is acceptable.





In no event will Rockwell Automation, Inc. be responsible or liable for indirect or consequential damages resulting from the use or application of this equipment.

The examples and diagrams in this manual are included solely for illustrative purposes. Because of the many variables and requirements associated with any particular installation, Rockwell Automation, Inc. cannot assume responsibility or liability for actual use based on the examples and diagrams.

No patent liability is assumed by Rockwell Automation, Inc. with respect to use of information, circuits, equipment, or software described in this manual.

Reproduction of the contents of this manual, in whole or in part, without written permission of Rockwell Automation, Inc., is prohibited.

Throughout this manual, when necessary, we use notes to make you aware of safety considerations.

	WARNING: Identifies information about practices or circumstances that can cause an explosion in a hazardous environment, which may lead to personal injury or death, property damage, or economic loss.
	ATTENTION: Identifies information about practices or circumstances that can lead to personal injury or death, property damage, or economic loss. Attentions help you identify a hazard, avoid a hazard and recognize the consequences.
	SHOCK HAZARD: Labels may be on or inside the equipment (for example, drive or motor) to alert people that dangerous voltage may be present.
	BURN HAZARD: Labels may be on or inside the equipment (for example, drive or motor) to alert people that surfaces may reach dangerous temperatures.
IMPORTANT	Identifies information that is critical for successful application and understanding of the product.



Overview

In addition to providing the module's electrical specifications, this document tells you how to:

- install the module into a chassis.
- wire the module's terminal block.
- install the Octal Filter Label.

North American Hazardous Location Approval

The following modules are North American Hazardous Location approved: 1746-IA4, 1746-IA8, 1746-IA16, 1746-IB8, 1746-IB16, 1746-IC16, 1746-IG16, 1746-IH16, 1746-IM4, 1746-IM8, 1746-IM16, 1746-IN16, 1746-ITB16, 1746-ITV16, 1746-IV8, 1746-IV16, 1746-OA8, 1746-OA16, 1746-OAP12, 1746-OB8, 1746-OB6EI, 1746-OB16, 1746-OB16E, 1746-OBP8, 1746-OBP16, 1746-OG16, 1746-OV8, 1746-OV16, 1746-OVP16, 1746-OW4, 1746-OW8, 1746-OW16, 1746-OX8, 1746-IO4, 1746-IO8, 1746-IO12, 1746-IO12DC.

The following information applies when operating this equipment in hazardous locations:	Informations sur l'utilisation de cet équipement en environnements dangereux:
<p>Products marked "CL I, DIV 2, GP A, B, C, D" are suitable for use in Class I Division 2 Groups A, B, C, D, Hazardous Locations and nonhazardous locations only. Each product is supplied with markings on the rating nameplate indicating the hazardous location temperature code. When combining products within a system, the most adverse temperature code (lowest "T" number) may be used to help determine the overall temperature code of the system. Combinations of equipment in your system are subject to investigation by the local Authority Having Jurisdiction at the time of installation.</p>	<p>Les produits marqués "CL I, DIV 2, GP A, B, C, D" ne conviennent qu'à une utilisation en environnements de Classe I Division 2 Groupes A, B, C, D dangereux et non dangereux. Chaque produit est livré avec des marquages sur sa plaque d'identification qui indiquent le code de température pour les environnements dangereux. Lorsque plusieurs produits sont combinés dans un système, le code de température le plus défavorable (code de température le plus faible) peut être utilisé pour déterminer le code de température global du système. Les combinaisons d'équipements dans le système sont sujettes à inspection par les autorités locales qualifiées au moment de l'installation.</p>
<div style="display: flex; align-items: center;">  <div> <p>EXPLOSION HAZARD</p> <ul style="list-style-type: none"> • Do not disconnect equipment unless power has been removed or the area is known to be nonhazardous. • Do not disconnect connections to this equipment unless power has been removed or the area is known to be nonhazardous. Secure any external connections that mate to this equipment by using screws, sliding latches, threaded connectors, or other means provided with this product. • Substitution of any component may impair suitability for Class I, Division 2. • If this product contains batteries, they must only be changed in an area known to be nonhazardous. </div> </div>	<div style="display: flex; align-items: center;">  <div> <p>RISQUE D'EXPLOSION</p> <ul style="list-style-type: none"> • Couper le courant ou s'assurer que l'environnement est classé non dangereux avant de débrancher l'équipement. • Couper le courant ou s'assurer que l'environnement est classé non dangereux avant de débrancher les connecteurs. Fixer tous les connecteurs externes reliés à cet équipement à l'aide de vis, loquets coulissants, connecteurs filetés ou autres moyens fournis avec ce produit. • La substitution de tout composant peut rendre cet équipement inadapté à une utilisation en environnement de Classe I, Division 2. • S'assurer que l'environnement est classé non dangereux avant de changer les piles. </div> </div>

Environment and Enclosure



ATTENTION: This equipment is intended for use in a Pollution Degree 2 industrial environment, in overvoltage Category II applications (as defined in IEC 60664-1), at altitudes up to 2000 m (6562 ft) without derating.

This equipment is not intended for use in residential environments and may not provide adequate protection to radio communication services in such environments.

This equipment is supplied as open-type equipment. It must be mounted within an enclosure that is suitably designed for those specific environmental conditions that will be present and appropriately designed to prevent personal injury resulting from accessibility to live parts. The enclosure must have suitable flame-retardant properties to prevent or minimize the spread of flame, complying with a flame spread rating of 5VA or be approved for the application if nonmetallic. The interior of the enclosure must be accessible only by the use of a tool. Subsequent sections of this publication may contain additional information regarding specific enclosure type ratings that are required to comply with certain product safety certifications.

In addition to this publication, see the following:

- Industrial Automation Wiring and Grounding Guidelines, publication [1770-4.1](#), for additional installation requirements.
 - NEMA Standard 250 and IEC 60529, as applicable, for explanations of the degrees of protection provided by enclosures.
-

Prevent Electrostatic Discharge



ATTENTION: This equipment is sensitive to electrostatic discharge, which can cause internal damage and affect normal operation. Follow these guidelines when you handle this equipment:

- Touch a grounded object to discharge potential static.
 - Wear an approved grounding wriststrap.
 - Do not touch connectors or pins on component boards.
 - Do not touch circuit components inside the equipment.
 - Use a static-safe workstation, if available.
 - Store the equipment in appropriate static-safe packaging when not in use.
-

Install and Remove the Module



ATTENTION: Never install, remove, or wire modules with power applied to chassis.

IMPORTANT The first slot of the chassis is reserved for the processor or the 1747-ASB module.

Follow these steps to install the module:

1. Disconnect power.
2. Align the circuit board of module with the chassis card guide. (A)
3. Slide the module into the chassis until the bottom tabs lock into place. (B)
4. Route the wires down and away from the module, securing them with the wire tie. (C)
5. Cover all unused slots with Card Slot Filler, catalog number 1746-N2, to keep the chassis free from debris.
6. To remove the module, press and hold the module release located on each self-locking tab, and slide the module out of the chassis slot. (D)

Module Installation

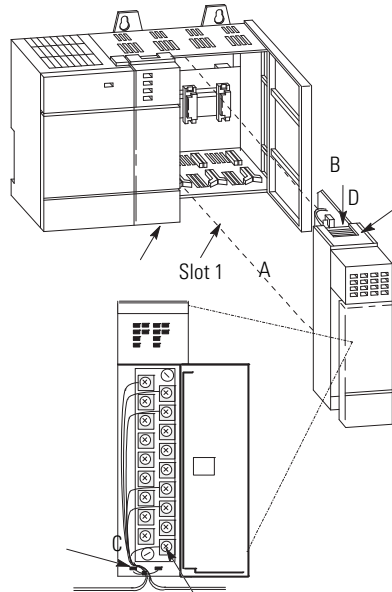

Max 2 mm² (14 AWG)
 Max 2 wires per terminal
 Max torque: 0.9 Nm (8 lb-in.)

Octal Label Kit Installation (for PLC processors only)

The octal label kit consists of an octal filter label and a door label. Use these octal labels to replace the decimal labels that are attached to the I/O modules.

TIP The octal label kit can be obtained from your Allen-Bradley distributor. The octal kit is ordered based on the catalog number of the I/O module.

Please refer to the SLC 500 Modular Hardware Style User Manual, publication [1747-UM011](#), for a listing of octal label kit catalog numbers.



ATTENTION: Do not touch or remove the terminal block when the SLC 500 system is powered. Contact with AC line potential may cause injury to personnel.

Apply the Octal Filter Label

1. Remove the octal filter label from its paper carrier.
2. Align the octal filter label numbers horizontally to the module color bar and over the decimal filter numbers.
Refer to [Installing Octal Labels on page 7](#) for filter label placement.
3. Apply the octal label to the filter.
4. Press firmly to be sure that the label adheres properly.

Apply the Octal Door Label

1. Remove the octal door label from its paper carrier.
2. Align the octal label directly over the decimal door label on the inside of the door.
Refer to [Installing Octal Labels on page 7](#) for door label placement.
3. Press firmly to be sure that the label adheres properly.

Removable Terminal Blocks

Colored terminal blocks are removable by loosening the upper and lower retaining screws. Black terminal blocks are not removable.

Installing Octal Labels

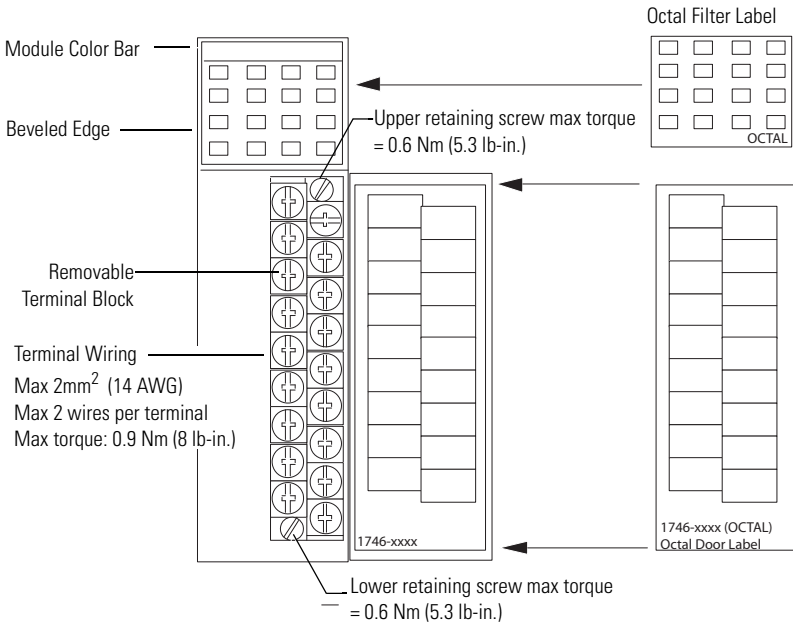

Fuse Protection and Blown Fuse Diagnostics

This section describes fusing characteristics for the following modules:

- 1746-OBP16
- 1746-OVP16
- 1746-OAP12

Fuse Protection (1746-OBP16 and 1746-OVP16 modules)

The fuse on the 1746-OBP16 and 1746-OVP16 modules (shown on [Location of Jumpers and Fuses for 1746-OBP16 and 1746-OVP16 Modules on page 9](#)) provides short-circuit protection for 13 mm² (16 AWG) or larger wiring to external loads. In the event of a short circuit on an output channel, it is likely that the transistor associated with that channel will be damaged. In this event, the module should be replaced or the load moved to a spare output channel.

The fuse does not provide overload protection. In the event of an overload on an output channel, it is likely that the fuse will not blow and the transistor associated with that channel will be damaged. To provide overload protection for your application, user-supplied fuses should be installed externally and properly sized to match your individual load characteristics.

Fuse Protection (1746-OAP12 modules)

A fuse is provided on each common of the 1746-OAP12 module (shown on [Location of Jumpers and Fuses for 1746-OAP12 Module on page 10](#)) for a total of two fuses. The fuses are designed to protect the module from short-circuit conditions. The fuse does not provide overload protection. In the event of an overload on an output channel, it is likely that the fuse will not blow and the output device associated with that channel will be damaged. To provide overload protection for your application, user-supplied fuses should be installed externally.

The recommended fuse for overload protection is SAN-O HT. Select the fuse rating according to your load. Do not use HT fuses rated higher than 2.0 Amps.

Blown Fuse Diagnostics

If the fuse blows on the 1746-OBP16, 1746-OVP16, or 1746-OAP12 module, the following occurs:

- The blown fuse LED indicator will illuminate, provided power (5V DC via backplane and load power via external supply) is applied to the module.
- A processor error will occur if JP1 connects pins 2 and 3. (See figures on [page 9](#) and [page 10](#).)

Location of Jumpers and Fuses for 1746-OBP16 and 1746-OVP16 Modules

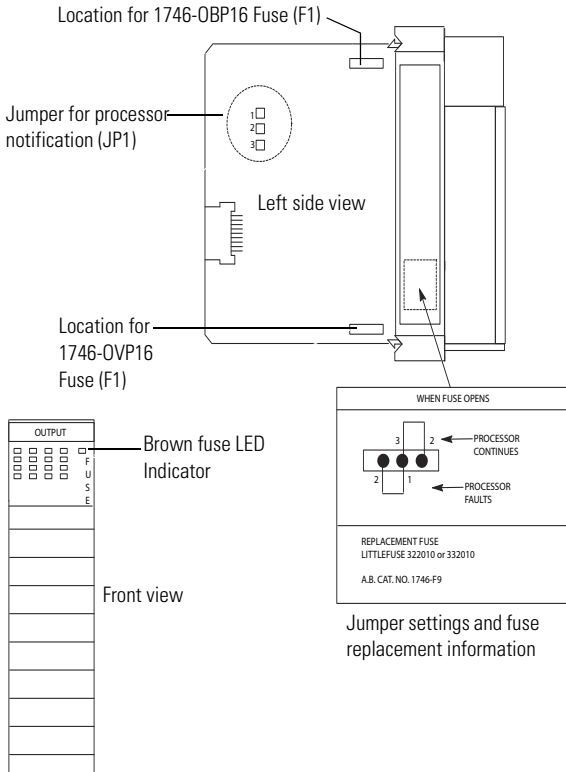

Location of Jumpers and Fuses for 1746-OAP12 Module

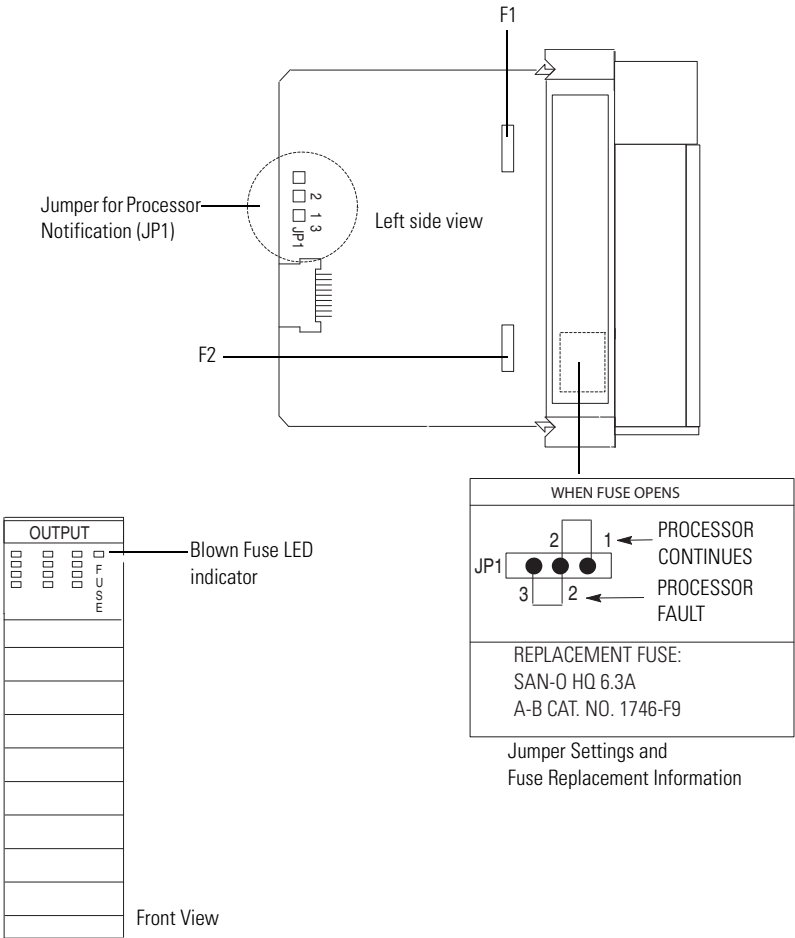

Processor Operation in Case of Blown Fuse – Processor Continues

The factory set position for JP1 is shown in the following diagram. For this JP1 configuration the processor operation will continue if the module fuse blows.

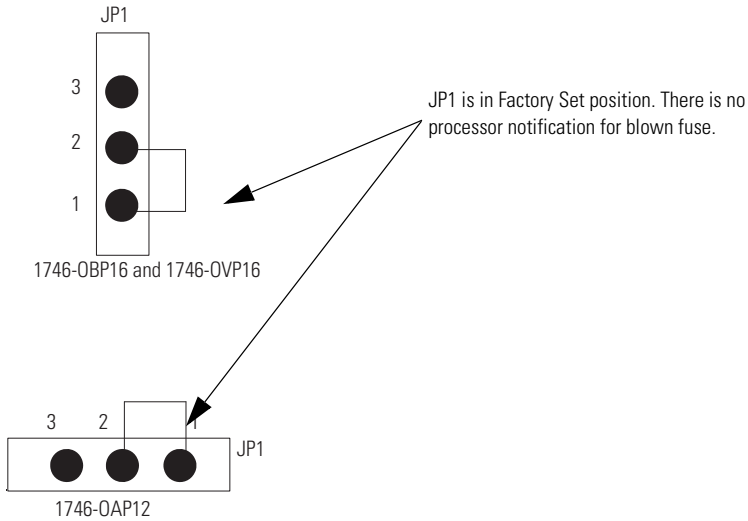

Processor Operation in Case of Blown Fuse – Processor Faults

The Processor Fault position for JP1 is shown on the following page. For this JP1 configuration, the processor generates a nonrecoverable error for all SLC 500 processors. For a nonrecoverable error, note the following:

- Processor operation halts and the processor fault light flashes.
- All outputs are reset to OFF.
- The processor major fault bit S:1/13 is set.
- Monitor processor status file word S:6 for error code xx58 for SLC 500, and SLC 5/01 processors, and error code xx60 for SLC 5/02 and later processors.

JP1 in Processor Fault Notification Position

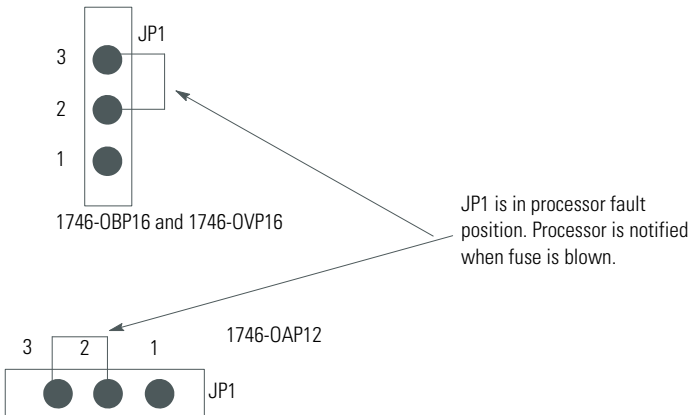

JP1 is in processor fault position. Processor is notified when fuse is blown.

IMPORTANT

When using SLC 5/02 processor and later processors, a user-fault routine cannot be used to clear the major fault bit.



ATTENTION: For 1746-OBP16 and 1746-OVP16 modules, all outputs on the module are OFF if the fuse blows. For the 1746-OAP12 module, all outputs on the same common as the blown fuse are OFF. If processor operation is allowed to continue after a blown fuse, extreme care should be taken to be sure the safety of personnel and guard against equipment damage.

For additional information on processor fault codes and user-fault routines refer to the following publications:

- Your programming device's reference manual
- HHT User Manual, publication 1747-NP002:
 - Chapter 28, Troubleshooting Faults
 - Chapter 29, Understanding the Fault Routine

1746-OV8, 1746-OV16, 1746-OVP16

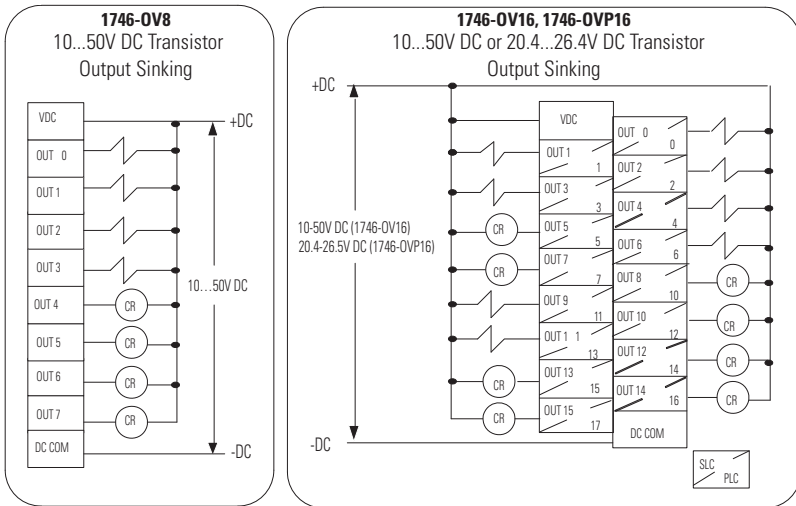

1746-OG16

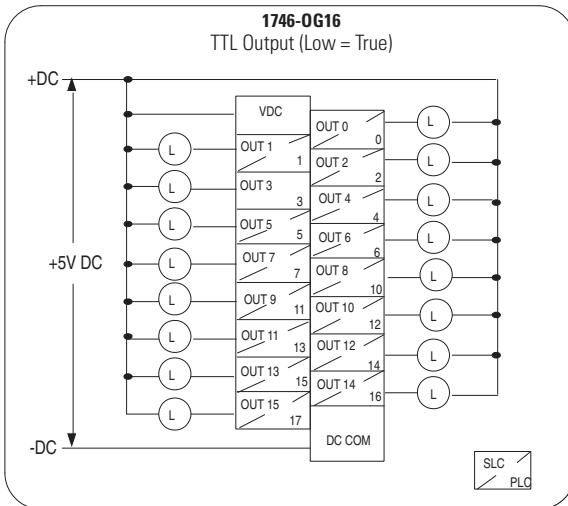

Input Modules Heat Dissipation

Catalog Numbers	Watts per Point	Minimum Watts	Total Watts
1747-IA4	0.27	0.175	1.30
1746-IA8	0.27	0.250	2.40
1746-IA16	0.27	0.425	4.80
1746-IB8	0.20	0.250	1.90
1746-IB16	0.20	0.425	3.60
1746-IC16	0.22	0.425	3.95
1746-IG16	0.02	0.700	1.00
1746-IH16	0.32	0.217	5.17
1746-IM4	0.35	0.175	1.60
1746-IM8	0.35	0.250	3.10
1746-IM16	0.35	0.425	6.00
1746-IN16	0.35	0.425	6.00
1746-ITB16	0.20	0.425	3.60
1746-ITV16	0.20	0.425	3.60
1746-IV8	0.20	0.250	1.90
1746-IV16	0.20	0.425	3.60

Output Modules Heat Dissipation

Catalog Numbers	Watts per Point	Minimum Watts	Total Watts
1746-OA8	1.000	0.925	9.00
1746-OA16	0.462	1.850	9.30
1746-OAP12	1.000	1.850	10.85
1746-OB6EI	0.440	0.230	2.90
1746-OB8	0.775	0.675	6.90
1746-OB16	0.388	1.400	7.60
1746-OB16E	0.150	0.675	3.07
1746-OBP8	0.300	0.675	3.08
1746-OBP16	0.310	1.250	6.26
1746-OG16	0.033	0.900	1.50

- (8) Fast turn-off modules (1746-OB6EI, 1746-OBP8 series B and later, 1746-OB16E series B and later, 1746-OBP16, and 1746-OVP16) provide fast OFF delay for inductive loads. Comparative OFF delay times for 1746-OB8/1746-QV8 and fast turn-off modules; when switching Bulletin 100-B110 (24Ws sealed) contactor, are: 1746-OB8/1746-QV8 OFF delay = 152 ms; fast turn-off modules OFF delay = 47 ms.
- (9) Fast off delay for inductive loads is accomplished with surge suppressors on the 1746-OB6EI, 1746-OBP8 series B and later, 1746-OB16E series B and later, 1746-OBP16, and 1746-OVP16 modules. A suppressor at the load is not needed unless another contact is connected in series. If this is the case, a 1N4004 diode should be reverse wired across the load. This defeats the fast turn-off feature.
- (10) Surge current = 32 A per module for 10 ms.



ATTENTION: A transient pulse occurs in transistor outputs when the external DC supply voltage is applied to the output common terminals (for example, via the master control relay). This can occur regardless of the processor having power or not. For most applications, the energy of this pulse is not sufficient to energize the load.

Refer to the SLC 500 Modular Hardware Style User Manual, publication [1747-UM011](#), for more information on transient pulses and guidelines to reduce inadvertent processor operation.

Specifications – 1746-0G16

Attribute		Value ⁽¹⁾
Voltage category		5V DC TTL Signal Input (sinking)
Number of outputs		16
Points per common		16
Voltage, operating (V DC to DC COM)		4.5...5.5V DC ⁽²⁾ 50 mV peak to peak ripple, max.
Backplane current consumption	5V DC	0.180 A
	24V DC	0.0 A
Signal delay, max resistive load		On = 0.25 mA Off = 0.50 mA
Off-state voltage		4.5...5.5V DC
Off-state leakage, max		0.1 mA
Load current, min		0.15 mA
Continuous current per point		24 mA

⁽¹⁾ Removable terminal block.

⁽²⁾ TTL outputs are inverted (0...0.4V DC = low voltage = True = ON). Use a NOT instruction in your ladder program to convert to traditional True = High logic.