

Overview

Chapter Objectives

Chapter 1 provides an overview of the Remote I/O communications module (1203-GD1 module, 1203-GK1 module, and 1336-GM1 board). In this chapter, you will read about the following:

- Function of the module.
- Features of the module.
- Compatible SCANport products and programmable controllers.
- Parts and hardware of the module.
- Steps for setting up the module.
- Required tools and equipment.

Description of the Remote I/O Communications Modules

The Remote I/O communications module is an optional interface designed to provide a direct, digital link between an Allen-Bradley programmable controller and any one Allen-Bradley SCANport product. A module is required for each product that you want to connect to Remote I/O. There are three types of Remote I/O communications modules:

Catalog Number	Enclosure	Required Power Supply
1203-GD1	NEMA Type 1	85 – 264V AC
1203-GK1	NEMA Type 1	24V DC +/- 10%
1336-GM1	Open	Drive Supplied

Figure 1.1 Module and Board

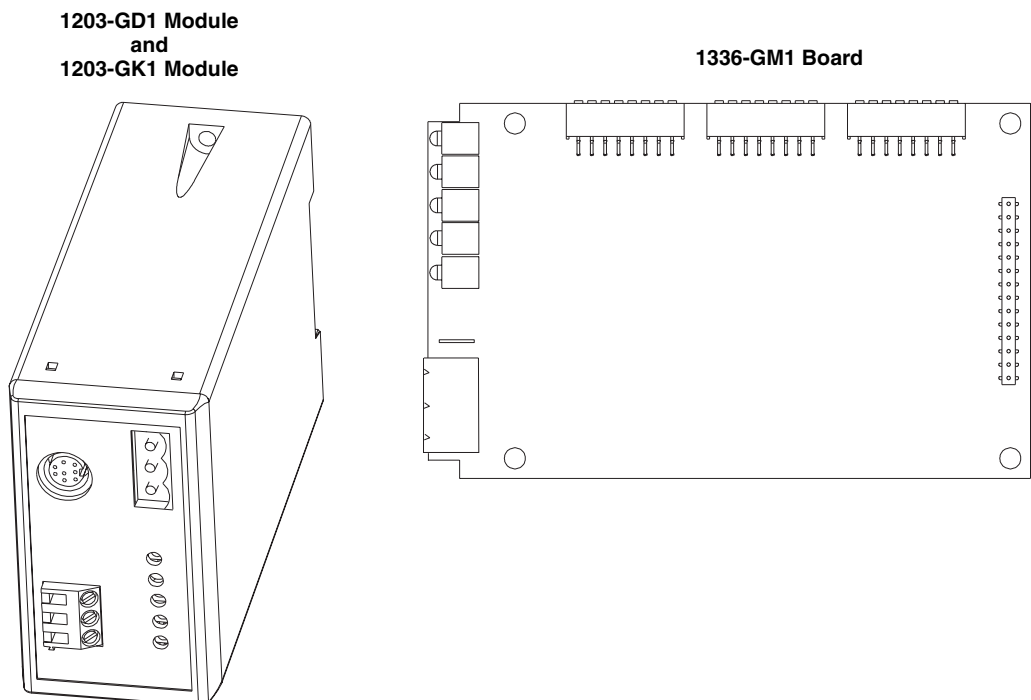

The 1203-GD1 and 1203-GK1 modules mount on a DIN rail. They connect to a SCANport product using a SCANport cable and to the Remote I/O link using a Remote I/O cable. The 1336-GM1 board mounts directly onto selected SCANport products. It connects to a SCANport product using an internal SCANport connector and to the Remote I/O link using a Remote I/O cable.

Figure 1.2 shows how the modules connect SCANport products to the Remote I/O link.

Figure 1.2 Remote I/O Link with Remote I/O Communications Modules

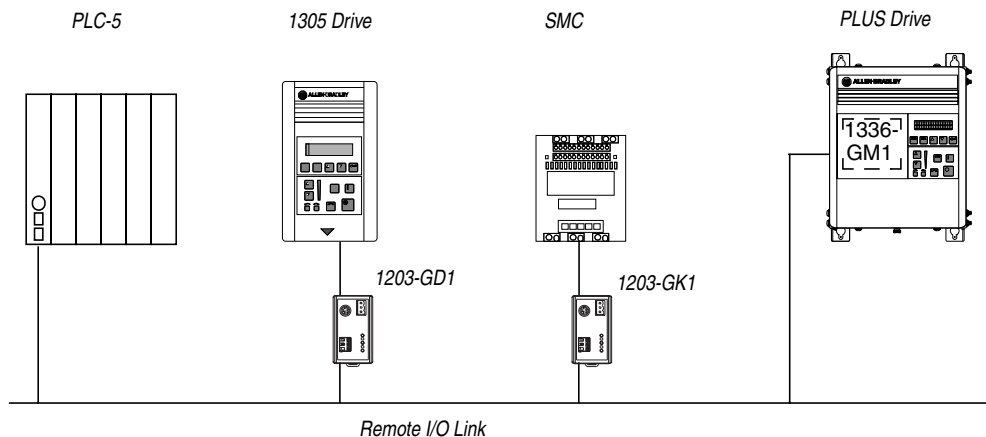

Features of the Communications Module

The 1203-GD1 module, 1203-GK1 module, and 1336-GM1 board let you connect SCANport products to Remote I/O links and devices. These modules feature the following:

- DIP switches let you configure how the Remote I/O module operates before connecting it to the link.
- User-configurable fault action DIP switches let you customize the module actions when communication errors occur.
- LEDs report link, module, and SCANport product health.
- Datalinks are supported in the module. Datalinks are a SCANport mechanism for transferring information between a controller and SCANport device. Each enabled datalink uses two words in the I/O image table unless it is truncated.

Compatibility

SCANport Products

Remote I/O modules are compatible with many SCANport products, including the following:

Product	Number of Peripherals Supported	I/O Words		Module Use	
		Minimum	Maximum ^③	1203-GD1 or 1203-GK1	1336-GM1
1305 AC MICRO Drive ^①	5	0	8	Yes	No
1336 IMPACT™ Drive	6 ^②	0	8	Yes	Yes ^④
1336 PLUS AC Drive	6 ^②	0	8	Yes	Yes ^④
1336 PLUS II Drive	6 ^②	0	8	Yes	Yes
1336 FORCE™ Drive	6 ^②	0	8	Yes	Yes ^④
1336 REGEN Line Regeneration Package	2	0	2 ^⑤	Yes	No
1336 SPIDER Drive	6 ^②	0	8	Yes	Yes
1394 AC Multi-Axis Motion Control System	5	0	8	Yes	No
SMC Dialog Plus™	1	0	2 ^⑤	Yes	No
SMP-3 Smart Motor Protector	2	0	2 ^⑤	Yes	No
1397 Digital DC Drive	5	0	8	Yes	No
1557 Medium Voltage Drive	5	0	8	Yes	No
2364F Regenerative DC Bus Supply Unit	6	0	8	Yes	No

① The Remote I/O modules are compatible with 1305 drives using firmware release 2.xx or greater.

② Lower horsepower products may not support a sixth peripheral. To connect multiple peripherals to a SCANport product, a port expander may be required. Refer to the product user manual to verify that it supports a sixth peripheral.

③ Many SCANport products support 10 words of I/O (Command/Logic, Speed Reference, and four datalinks). Remote I/O, however, supports only 8 words of I/O.

④ Drive must be B-frame or larger. If it is a 1336 FORCE drive, it must use a standard adapter board.

⑤ Datalinks are not supported by this product.

If you intend to use datalinks to communicate with and control your SCANport product, verify that your SCANport product supports datalinks before enabling them in the module.

Controllers

This Remote I/O communications module is compatible with many programmable controllers, including the following:

- Logix5550
- PLC-2/30® with SD2 (module version 1.02 or later)
- PLC-3®
- PLC Classic Family, including the PLC-5/10 (only with 1771-SN in Discrete Mode), PLC-5/15™, PLC-5/25™ family
- PLC Enhanced family, including the PLC-5/20™, PLC-5/30, PLC-5/40™, PLC-5/40L™, PLC-5/60™, PLC-5/60L™ family, PLC-5/80™
- PLC-5/250™
- PLC scanner modules and subscanners
- SLC 500™ with 1747-SN scanner

Hardware Description

The hardware included with the module depends on the module that you have.

1203-GD1 and 1203-GK1 Modules

The 1203-GD1 module and 1203-GK1 module share the same parts. Figure 1.3 illustrates these parts.

Figure 1.3 Parts of the 1203-GD1 and 1203-GK1 Module

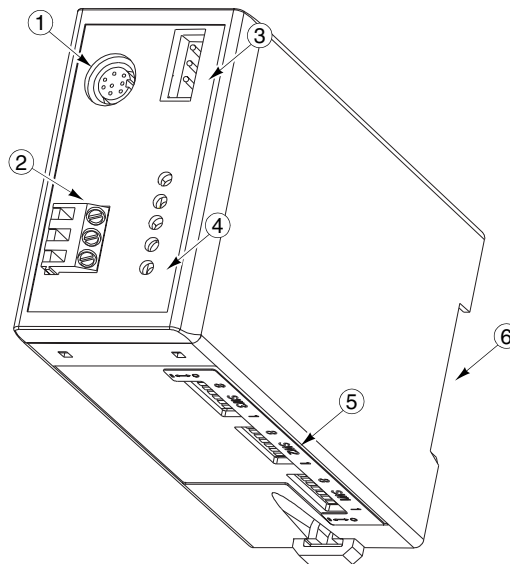

#	Part	Description
1	SCANport Connection	Standard SCANport 8-pin mini-DIN connector for the SCANport cable.
2	Power Supply Connections	Connections for the power supply. Multiple connections allow daisy-chaining. The 1203-GD1 module uses 85 – 264V AC. The 1203-GK1 module uses 24V DC.
3	Remote I/O Connection	Standard 3-pin Remote I/O connector.
4	LEDs	Status indicators for the module, SCANport connection, and Remote I/O connection. Refer to Chapter 6.
5	DIP Switches	Switches used to configure the module. Refer to Chapter 2.
6	DIN Rail Mount	Mount for securely attaching and electrically grounding the module to a DIN rail.
Not Shown	Remote I/O connector	One 3-pin connector for connecting the Remote I/O cable to the module.
Not Shown	Termination Resistors	Two termination resistors for terminating the I/O link at its physical ends. Refer to Chapter 3.

1336-GM1 Board Hardware

Figure 1.4 illustrates the main parts of a 1336-GM1 board.

Figure 1.4 **Parts of the 1336-GM1 Board**

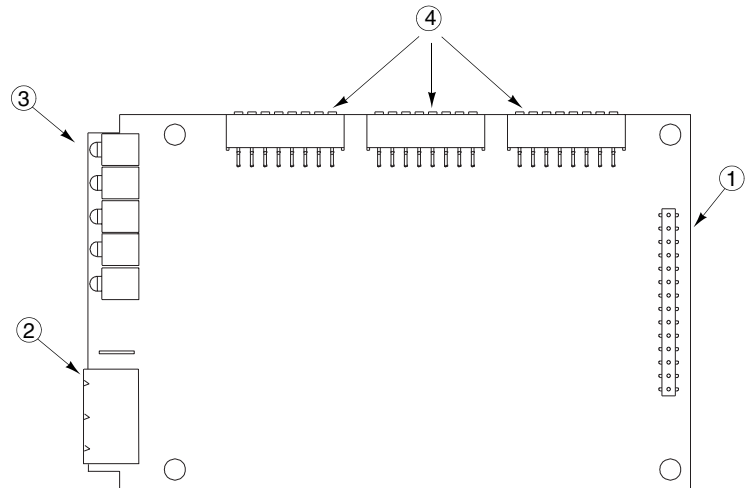

#	Part	Description
1	SCANport Connection	Internal 14-pin female SCANport connector.
2	Remote I/O Connection	Standard 3-pin Remote I/O connector.
3	LEDs	Status indicators for the module, SCANport connection, and Remote I/O connection. Refer to Chapter 6.
4	DIP Switches	Switches used to configure the module. Refer to Chapter 2.
Not Shown	Kit	Materials for mounting the board to the SCANport product. These material include one grounding wrist strap, four Phillips mounting screws, four stand-off nylon headers, one 3-pin Remote I/O connector, one snap-in comm housing with mounting instructions, and termination resistors.

Required Tools and Equipment

The tools and equipment required, depend on if you are using a 1203-GD1 module, 1203-GK1 module, or 1336-GM1 board.

1203-GD1 or 1203-GK1 Module

To install and configure a 1203-GD1 module or 1203-GK1 module, you need the following:

- Remote I/O communications module (1203-GD1 or 1203-GK1).
- 35 x 7.5 mm DIN rail.
- Termination resistor(s).
- Power source.
- 1/8" flathead screwdriver.
- Appropriate cables for SCANport and Remote I/O connections. Refer to Chapter 3.
- Software such as RSLogix5, RSLogix500, or RSLogix5000 for programming the controller.

1336-GM1 Board

To install and configure a 1336-GM1 board, you need the following:

- Remote I/O communications board (1336-GM1).
- A kit that includes one grounding wrist strap, four Phillips mounting screws, four stand-off nylon headers, one 3-pin connector, and one snap-in comm housing with mounting instructions (supplied with board).
- #1 Phillips screwdriver.
- Appropriate cable for the Remote I/O connection. Refer to Chapter 3.
- Software such as RSLogix5, RSLogix500, or RSLogix5000 for programming the controller.

Overview of Setting Up the Module

To set up the Remote I/O communications module, you must perform the following tasks:

1. Read the safety precautions in this manual.
2. Configure the module using the DIP switches. Refer to Chapter 2.
3. Install the module or mount the board. Refer to Chapter 3.
4. Create a ladder logic program to control the SCANport product (Chapter 4) or send messages to it (Chapter 5).

Configuring the Module

Chapter Objectives

Chapter 2 provides instructions and information for configuring the Remote I/O communications module (1203-GD1, 1203-GK1, or 1336-GM1). In this chapter, you will read about the following:

- Factory-default settings.
- Recording the I/O image table.
- Configuring the module.

Important: The communications module is not compatible with complementary I/O configurations because it uses both output and input image words for proper product control.

Safety Precautions and Important Information

Please observe the following safety precautions:



ATTENTION: Hazard of equipment damage exists. When you make changes to the switch settings, use a blunt, pointed instrument. Do not use a pencil or pen.



ATTENTION: Hazard of injury or equipment damage exists. Failure to check connections and switch settings for compatibility with your application could result in unintended or undesirable operation. Verify the configuration is correct for your application.



ATTENTION: Hazard of injury or equipment damage exists. Unintended or incorrect machine motion can result from the initial configuration. When a system is configured for the first time, the motor must be disconnected from the machine or process during initial system testing.

Important: Due to an anomaly in firmware release 4.01, Remote I/O modules that are used only for block transfer messages require the following configuration: switches for block transfer and reference/feedback should both be enabled (SW 3.1 and SW 3.3 are ON. SW 3.2 and SW 3.4 through 3.8 are OFF).

This configuration prevents a fault on power up. It does not affect rack I/O allocation or the ladder logic program because it still fits within 1/4 rack I/O space. The drive will, however, generate a serial fault if the communications module is disconnected or loses power.

Locating the DIP Switches

Figure 2.1 Switches on the 1203-GD1 and 1203-GK1 Modules

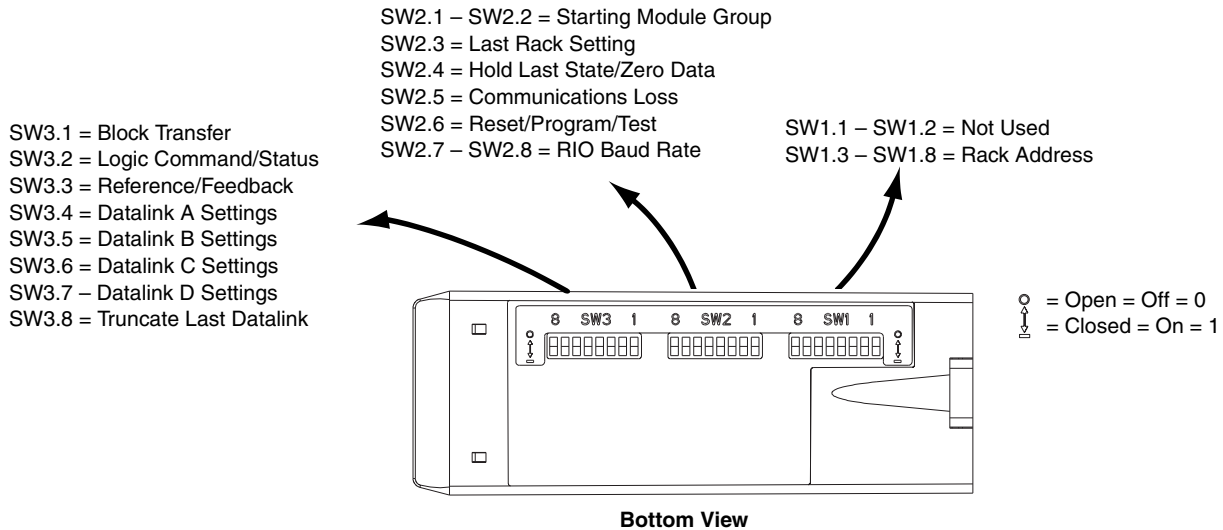
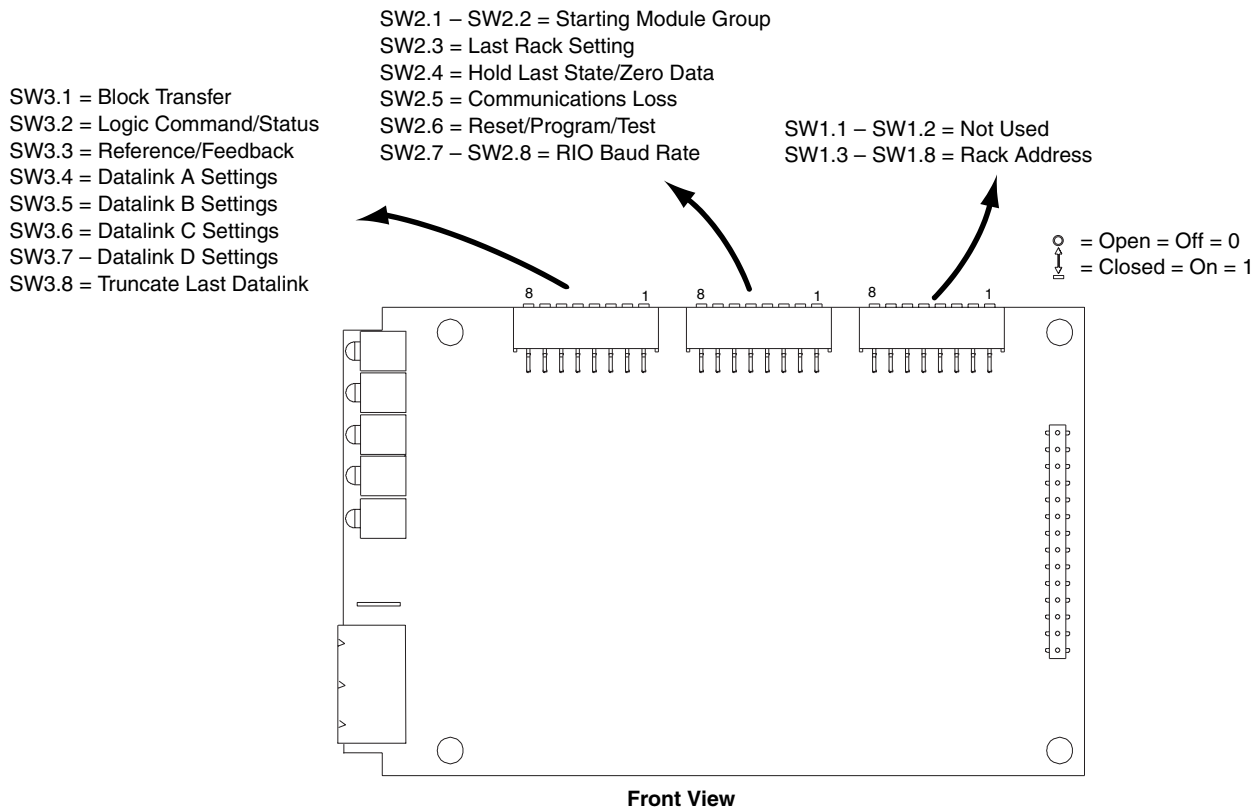

Figure 2.2 Switches on the 1336-GM1 Board



Installing the Module

Chapter Objectives

Chapter 3 provides the information that you need to install the module (1203-GD1 module, 1203-GK1 module, or 1336-GM1 board). In this chapter, you will read about the following:

- Selecting cables.
- Selecting a termination resistor.
- Installing a 1203-GD1 or 1203-GK1 module.
- Installing a 1336-GM1 board.

Selecting Cables

Refer to the following table to determine the required cables:

If Installing:	Required Cables
1203-GD1, 1203-GK1	SCANport and Remote I/O
1336-GM1	Remote I/O

SCANport Cables

When selecting the SCANport cable to connect a module to the SCANport product, you need to:

- Use an Allen-Bradley SCANport cable. Refer to the table below:

Male to Male Connection		Male to Female Connection ^①	
Length	Catalog Number	Length	Catalog Number
1/3 m	1202-C03	1/3 m	1202-H03
1 m	1202-C10	1 m	1202-H10
3 m	1202-C30	3 m	1202-H30
9 m	1202-C90	9 m	1202-H90

^① Cables with male to female connections are generally used as extension cables.

- Use 10 meters (33 feet) or less of cable between the SCANport product and all peripherals.
- Keep SCANport cables away from high power cables to guard against introducing noise into your system.

Important: SCANport cables lock into a connection. To remove a SCANport cable, you must push it in and then pull it out.

Remote I/O Cables

Remote I/O communications modules are connected to Remote I/O links with twinaxial cable used for Remote I/O and Data Highway Plus (DH+) communications. When selecting a cable, remember the following:

- Only 1770-CD Belden #9463 is tested and approved for RIO and DH+ installations. Using other cables is at your own risk.
- The total cable length depends on the baud rate that you are using. Refer to the following table:

Baud Rate	Maximum Length
57.6 K	3,048 m (10,000 ft)
115.2 K	1524 m (5,000 ft)
230.4 K	762 m (2,500 ft)

- All three of the following conductors must be connected at each node.

Color	Description
Blue	1
Shield	SH
Clear	2

- Do not use a star topology. Only two cables may be connected at any wiring point. You can use a series topology and daisy-chain two wires at a point.

Selecting a Termination Resistor

You must terminate both ends of a Remote I/O link to ensure proper operation. This termination is required only at the ends of the physical cable. Each Remote I/O link should have exactly two termination resistors.

If the device that you connect is an end device on the Remote I/O link, it must be terminated. Refer to the following table to select a resistor.

Important: You must use an 82 ohm external termination resistor if the link is operating at 230.4 kbps.

Device	Description
Programmable Controller	Refer to its manual.
1336-GM1 (Using Jumpers)	Set J2 in position 1-2 for termination and 2-3 for no termination. Refer to Figure 3.8. The jumper enables a 150 ohm resistor ^① .
1203-GD1, 1203-GK1, or 1336-GM1 (Using an external termination resistor)	Connect a resistor between terminals 1 and 2 on the Remote I/O connector. Refer to Figure 3.4. Use an 82 ohm termination resistor unless a device requires a 150 ohm termination resistor ^① .

^① The following scanners require 150 ohm termination resistors on the RIO link: 1771-SN, 1772-SD, 1772-SD2, 1775-SR, 1775-S4A, 1775-S4B, 6008-SQH1, and 6008-SQH.

The following adapters require a 150 ohm termination resistors on the RIO link: 1771-AS, 1772-ASB (Series A), 1771-DCM.

The following devices require a 150 ohm termination resistors on the RIO link: 1771-AF.

Installing a 1203-GD1 or 1203-GK1 Module

Required Tools and Equipment

To install your module, you need the following tools and equipment:

- Remote I/O communications module (1203-GD1 or 1203-GK1).
- 35 x 7.5 mm DIN rail.
- Appropriate cables for SCANport and Remote I/O connections. Refer to the “Selecting Cables” section in this chapter.
- Termination resistor (if necessary). Refer to the “Selecting a Termination Resistor” section in this chapter.
- 115 V/230 V AC or 24 V DC power supply.

Installing the 1203-GD1 or 1203-GK1 Module

1. Remove power from the Remote I/O link.
2. Hook the top lip of the module DIN rail mount onto the top of the DIN rail and then rotate the module onto the DIN rail. It snaps into a locked position.

Figure 3.1 Mounting a Module onto the DIN Rail

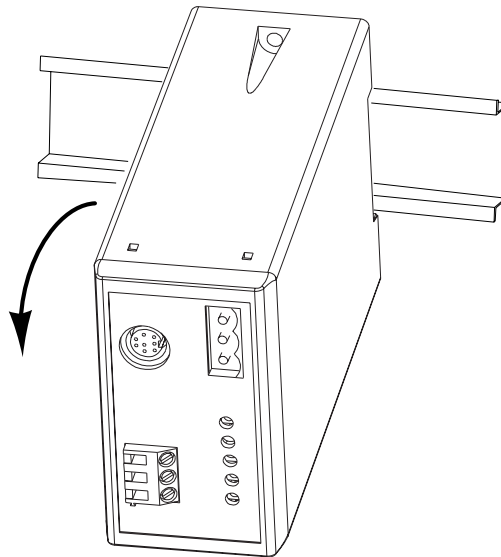

3. Connect a SCANport cable (1202-Cxx) to a module and product.

Important: For the location of the SCANport connector on your product, refer to its user manual. If you are using a port expander, refer to its documentation.

Figure 3.2 Connecting the SCANport Cable

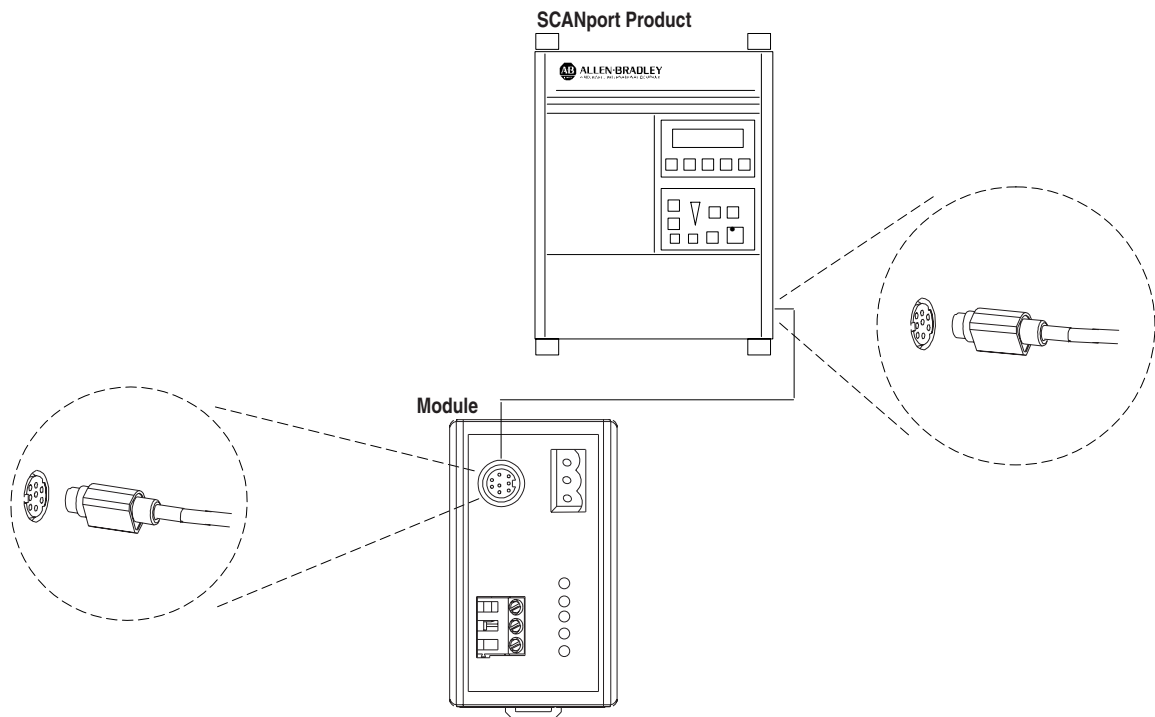

4. Connect a Remote I/O cable to the module and link or controller.

Figure 3.3 Connecting the Remote I/O Cable

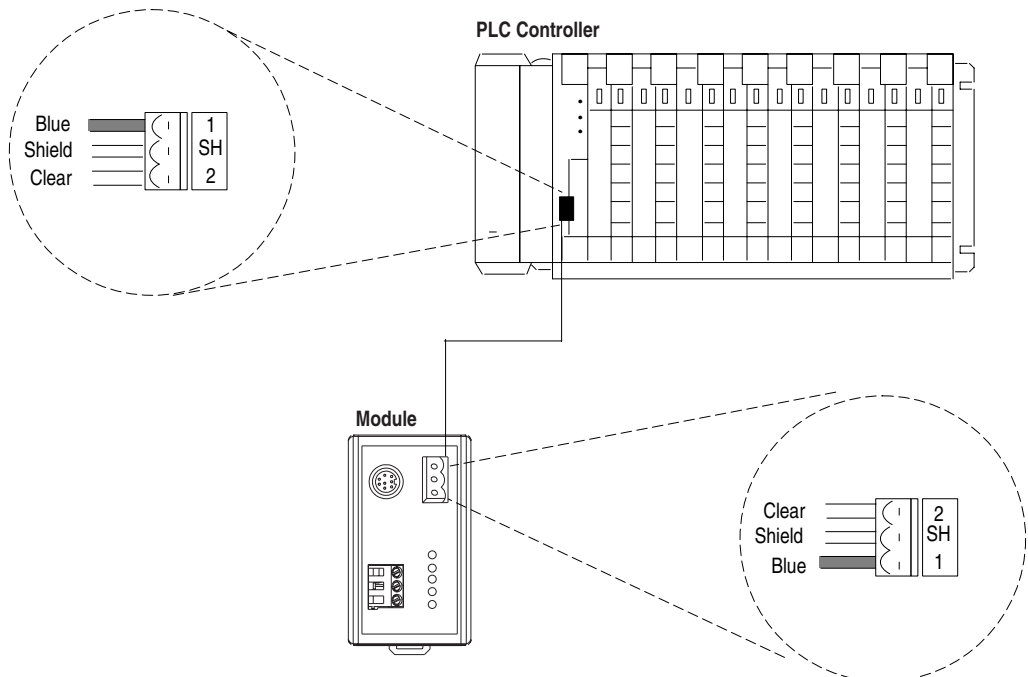

- If the module is the last device on the Remote I/O link, connect the termination resistor. If the Remote I/O link uses 230Kbps, you must use an 82 ohm termination resistor.

Figure 3.4 Connecting the Termination Resistor

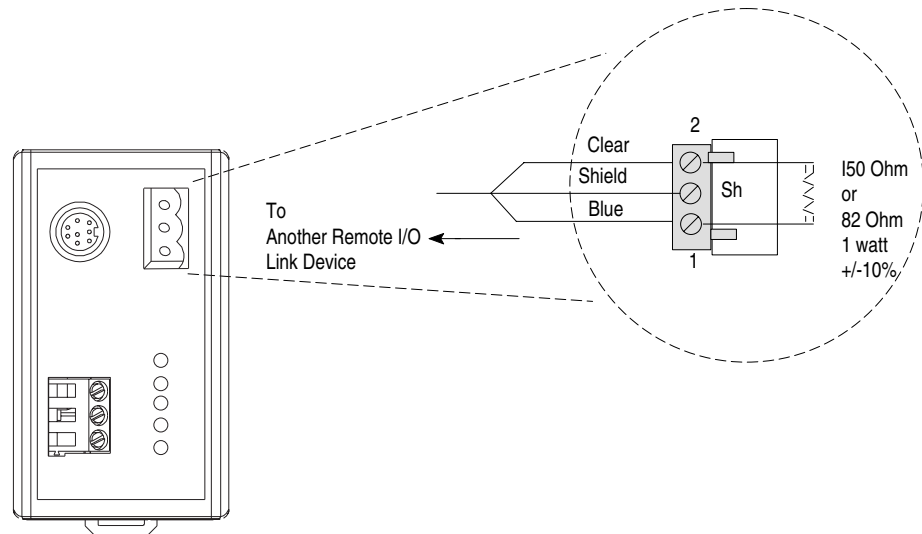

- Connect the power supply to the module.

Figure 3.5 Connecting the Power Supply

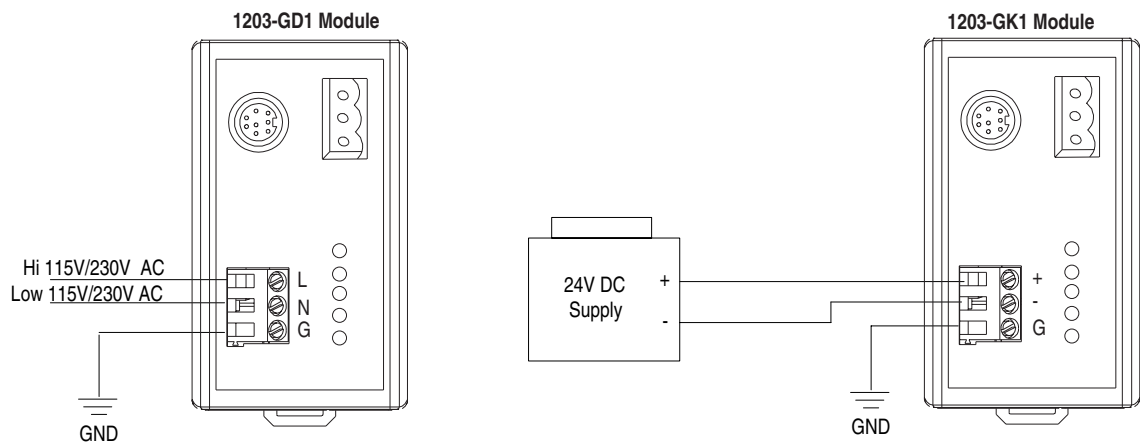

- Apply power to the Remote I/O link. The module is now installed. Its LEDs are as follows:

LED	Status
Fault	Red (Blinking)
SCANport STS	Green or amber ^{① ②}
Health	Green or amber ^②
Rem I/O ACT	Off
Rem I/O STS	Off

^① This LED is off if the module use firmware 2.xx or lower.

^② Early versions of the module use amber LEDs.

You are now ready to create a ladder logic program.

Important: If your LEDs are different, refer to Chapter 6.

Understanding Data Storage

In order to use the block transfer instructions in the ladder program, it is necessary to reserve several words for data storage. Some of these words are required for internal use by the block transfer function, and some contain the block transfer message information. Refer to Appendix B for detailed information on the required data in data files for different block transfer messages.

Example PLC Block Transfers

Figure 5.3 and Figure 5.4 are examples of block transfer programming from PLC controllers to a Remote I/O communications module. The BTW_AVAIL and BTR_AVAIL bits from the module status word (I:010 in these examples) are used in these examples. The examples also show how user logic can be used to enable or disable the block transfer operations.

Figure 5.3 Example for a PLC-5/15 or PLC-5/25

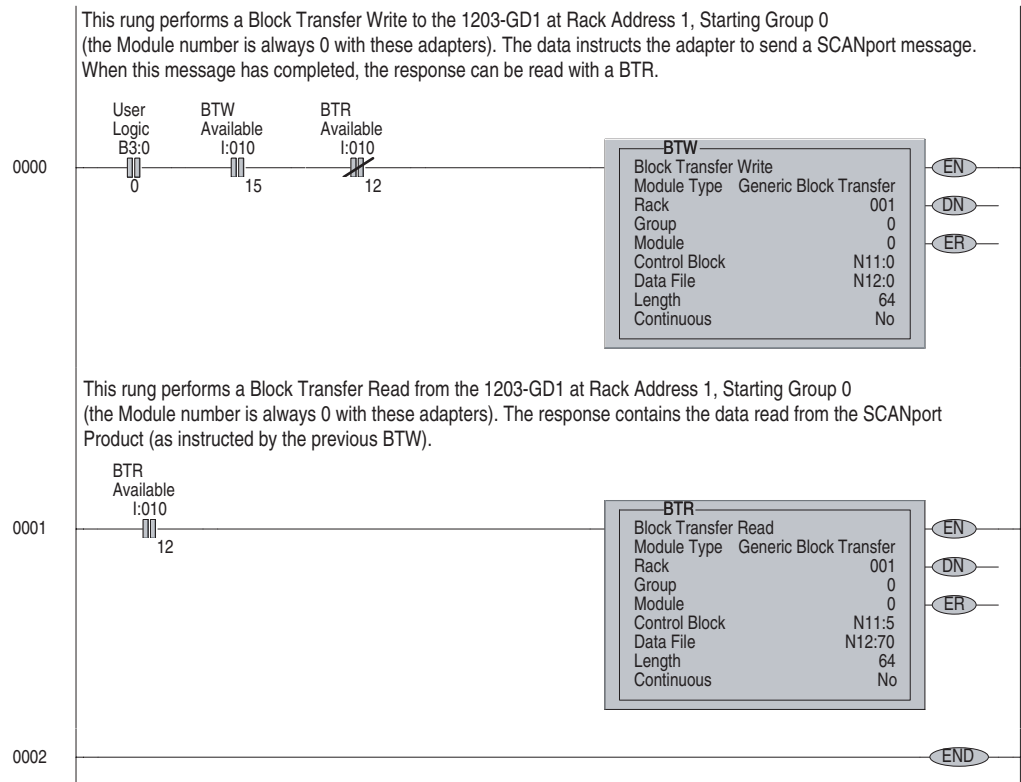
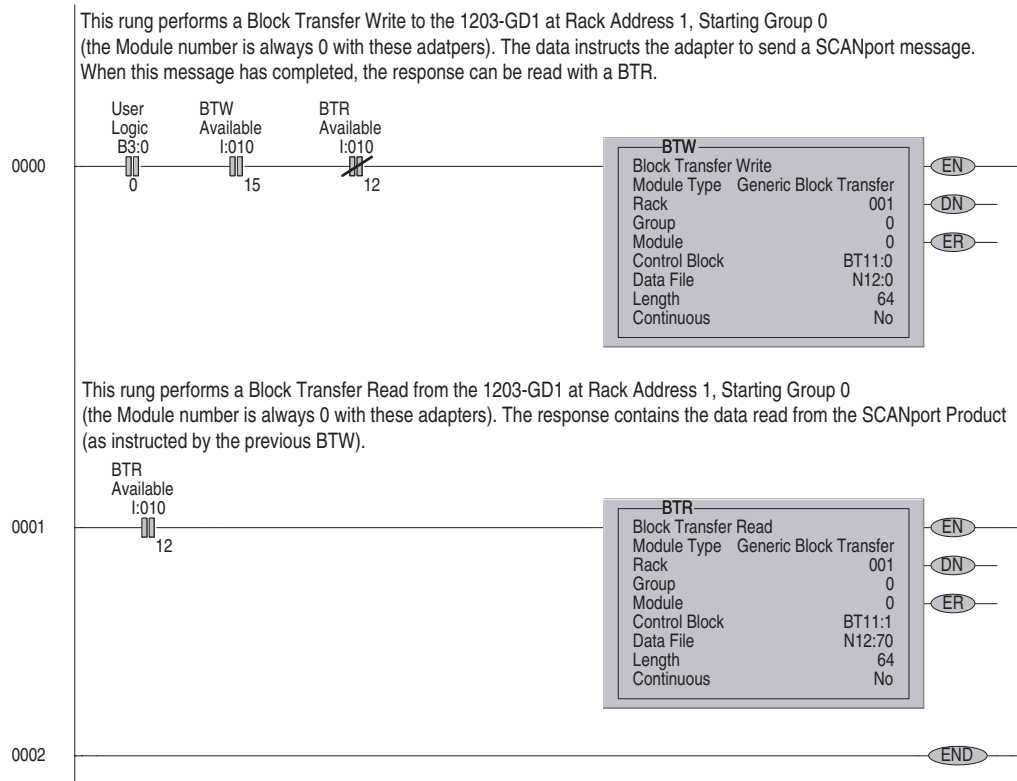

Figure 5.4 Example for a PLC-5/20, PLC-5/40, PLC-5/60, PLC-5/80



The following table defines the contents of the example PLC block transfer messages (Figure 5.3 and Figure 5.4).

Content	Description
Rack	The rack address is determined by the switch settings on the Remote I/O module. (Refer to Chapter 2.) In Figure 5.3 and Figure 5.4, rack address 1 is used.
Group	The group number is the first group in the rack associated with the Remote I/O module. This is called the starting group. It is determined by the size of the rack. (Refer to Chapter 2.) In Figure 5.3, the rack has been set up as a full 8 group rack; therefore, the starting group 0 is used.
Module	The module number is associated with the block transfer in the associated slot. This will always be 0.
Control Block	The control block is a predefined set of words that contain bit information associated with the block transfer function. In the PLC-5/15 and PLC-5/25, the control block requires 5 contiguous words. In the PLC 5/40 and 5/60 the control block may be either an integer type, and would require 5 contiguous words, or a block transfer type and would require 1 element. In Figure 5.3, words N11:0 through N11:4 have been reserved for the bit array in the BTW block. Words N11:5 through N11:9 have been reserved for the BTR block. In Figure 5.4, element BT11:0 has been reserved for the bit array in the BTW block. Element BT11:1 has been reserved for the BTR block.
Data File	The data file is the address of the message sent by the BTW or received by the BTR block. It contains both header and data information. The number of words required for the data file is dependent on the type of message being sent. Refer to Appendix B for information regarding the header and data that must be included in the data file for each message. In Figure 5.3 and Figure 5.4, N12:0 is the first word in the data file for the BTW block and N12:70 is the first word for the BTR block.
Length	Length specifies the length of the block transfer message in words. It varies depending on the type of message being sent. The BTW and BTR instruction lengths may be different. Refer to the message examples in Appendix B for the minimum lengths required for each message.
Continuous	Continuous specifies whether the block transfer block is to be executed continuously or only when the rung is true. This should always be set to No.

Troubleshooting

Chapter Objectives

Chapter 6 provides information about the LEDs on the Remote I/O modules. It also provides basic troubleshooting procedures. In this chapter, you will read about the following:

- Locating the LEDs.
- Using the LEDs to troubleshoot.

LEDs on the Remote I/O Communications Module

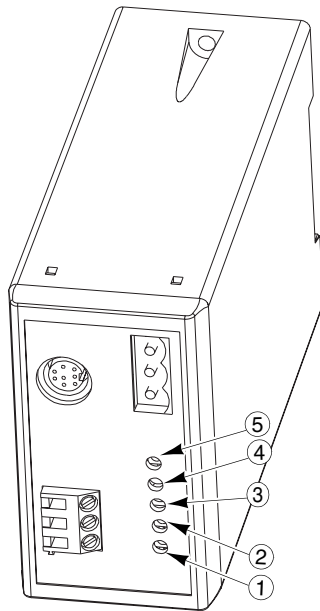

**1203-GD1 Module and
1203-GK1 Module**

**Figure 6.1
LED Status Indicators**

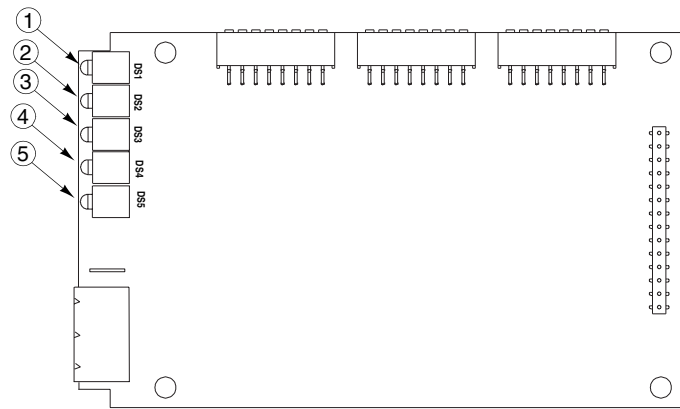

1336-GM1 Board

Number	LED	Color
1	Fault	Red
2	SCANport STS	Green ^①
3	Health	Green ^①
4	Rem I/O ACT	Green ^①
5	Rem I/O STS	Green

^① Early versions of Remote I/O modules may use amber LEDs instead of green.

FAULT LED

LED Status	Cause	Corrective Action
Red (Steady)	<ul style="list-style-type: none"> Unrecoverable Fault 	<ul style="list-style-type: none"> Replace the module.
Red (Blinking)	<ul style="list-style-type: none"> Recoverable Fault If Health LED is steady, a DIP switch is set incorrectly, there is a bad cable, or an RIO connection between the controller and adapter has not been made. 	<ul style="list-style-type: none"> Verify that the module is configured correctly. Verify that the SCANport and Remote I/O cables are correctly wired and securely connected. Configure or auto-configure the controller.^②
Off	<ul style="list-style-type: none"> Normal Operation 	<ul style="list-style-type: none"> None

SCANport STS LED

LED Status ^①	Cause	Corrective Action
Green (Steady)	<ul style="list-style-type: none"> Normal Operation 	<ul style="list-style-type: none"> None
Green (Blinking)	<ul style="list-style-type: none"> If FAULT LED is also blinking, the connected device is not compatible. 	<ul style="list-style-type: none"> Verify that the connected product is compatible. Refer to Chapter 1.
Off	<ul style="list-style-type: none"> No SCANport Connection. 	<ul style="list-style-type: none"> Verify that the module is connected to the SCANport product. Verify that the SCANport product is powered. Cycle power to the module.

Health LED

LED Status ^①	Cause	Corrective Action
Green (Steady)	<ul style="list-style-type: none"> Normal Operation If FAULT LED is steady, a DIP switch is set incorrectly, there is a bad cable, or an RIO connection between the controller and adapter has not been made. 	<ul style="list-style-type: none"> None Verify that the module is correctly configured. Verify that SCANport and Remote I/O cables are correctly wired and securely connected. Configure or auto-configure the controller.^②
Off	<ul style="list-style-type: none"> Internal module fault 	<ul style="list-style-type: none"> Cycle power.

Rem I/O ACT LED

LED Status ^①	Cause	Corrective Action
Green (Steady)	<ul style="list-style-type: none"> Normal Operation 	<ul style="list-style-type: none"> None
Off	<ul style="list-style-type: none"> No data is being received from the controller. 	<ul style="list-style-type: none"> Verify that Remote I/O is online. Verify that the controller is in run mode. Verify that rack addressing is set correctly. Verify that the module is connected to the controller.

Rem I/O STS LED

LED Status	Cause	Corrective Action
Green (Steady)	<ul style="list-style-type: none"> Normal Operation 	<ul style="list-style-type: none"> None
Green (Blinking)	<ul style="list-style-type: none"> Controller is in reset, program, or test mode. Controller has more rack space allocated than is used. 	<ul style="list-style-type: none"> Return the controller to run mode. Configure or auto-configure the controller.^②
Off	<ul style="list-style-type: none"> Module is not communicating with the controller. Module is not connected to the product. 	<ul style="list-style-type: none"> Verify that the module is connected to the controller. Verify that the controller is configured to recognize the module. Verify that the module is connected to the SCANport product.

^① Early versions of Remote I/O modules use amber LEDs instead of green.

^② The SCANport product should be powered to ensure a successful auto-configure.

Specifications

Appendix Objectives

Appendix A provides the specifications for the 1203-GD1 module, 1203-GK1 module, and the 1336-GM1 board.

Important: Remote I/O communications modules are non-repairable units.

1336-GM1 Board Specifications

The following table gives the specifications for the 1336-GM1 board.

	Category	Specifications
Electrical	Input Voltage	Supplied by the drive
	Input Current	Not Applicable
	Input Frequency	Not Applicable
	SCANport Load	60mA DC
Environmental	Operating Temperature	0 to +50°C (32 to 122°F)
	Storage Temperature	-40 to +85°C (-40 to 185°F)
	Relative Humidity	0 – 95%, non-condensing
Communications	Product	SCANport
	Controller	Allen-Bradley Remote I/O
	Baud Rates	57.6K, 115.2K, 230.4K
	Rack Sizes	1/4, 1/2, 3/4, full
Mechanical	Height	71 mm (2.8")
	Width	114 mm (4.5")
	Depth	127 mm (0.5")
	Enclosure	Open (IP00)
Regulatory Agencies	UL	
	CSA	
	CE	



ATTENTION: The 1336-GM1 communications board contains ESD (Electrostatic Discharge) sensitive parts. Static control precautions are required when installing and removing this assembly. Device malfunction may occur if you do not follow ESD control procedures. If you are not familiar with static control procedures, refer to Rockwell Automation Publication 8000-4.5.2, *Guarding Against Electrostatic Damage*, or other applicable ESD protection handbook.

1203-GD1 Module Specifications

The following table gives the specifications for the 1203-GD1 module.

	Category	Specifications
Electrical	Input Voltage	85 to 264 V AC, 1 phase
	Input Current	35 mA maximum
	Input Frequency	45 to 63 Hz
	SCANport Load	60mA DC
Environmental	Operating Temperature	0 to +50°C (32 to 122°F)
	Storage Temperature	-40 to +85°C (-40 to 185°F)
	Relative Humidity	0 – 95%, non-condensing
Communications	Product	SCANport
	Controller	Allen-Bradley Remote I/O
	Baud Rates	57.6K, 115.2K, 230.4K
	Rack Sizes	1/4, 1/2, 3/4, full
Mechanical	Height	76 mm (3.0")
	Width	45 mm (1.8")
	Depth	123 mm (4.8")
	Enclosure	NEMA Type 1 (IP30)
	DIN Rail Standard	35 x 7.5 mm (1.38 x 0.30 in)
Regulatory Agencies	UL	
	CSA	
	CE	

1203-GK1 Module Specifications

The following table gives the specifications for the 1203-GK1 module.

	Category	Specifications
Electrical	Input Voltage	24 V DC, +/- 10%
	Input Current	0.4 A maximum
	SCANport Load	60mA DC
Environmental	Operating Temperature	0 to +50°C (32 to 122°F)
	Storage Temperature	-40 to +85°C (-40 to 185°F)
	Relative Humidity	0 – 95%, non-condensing
Communications	Product	SCANport
	Controller	Allen-Bradley Remote I/O
	Baud Rates	57.6K, 115.2K, 230.4K
	Rack Sizes	1/4, 1/2, 3/4, full
Mechanical	Height	76 mm (3.0")
	Width	45 mm (1.8")
	Depth	123 mm (4.8")
	Enclosure	NEMA Type 1 (IP30)
	DIN Rail Standard	35 x 7.5 mm (1.38 x 0.30 in)
Regulatory Agencies	UL	
	CSA	
	CE	