

Chapter Objectives

Overview

Chapter 1 provides an overview of your Enhanced DeviceNet communications adapter. In this chapter, you will read about the following:

- Function of the 1203-GU6 module or 1336-GM6 board.
- Features of the 1203-GU6 module and 1336-GM6 board.
- SCANport products.
- Parts and hardware of the 1203-GU6 module and 1336-GM6 board.
- Steps for setting up the adapter.
- Required tools and equipment.

Overview of the Communications Adapter

There are two types of Enhanced DeviceNet adapters: the 1203-GU6 module and 1336-GM6 board.

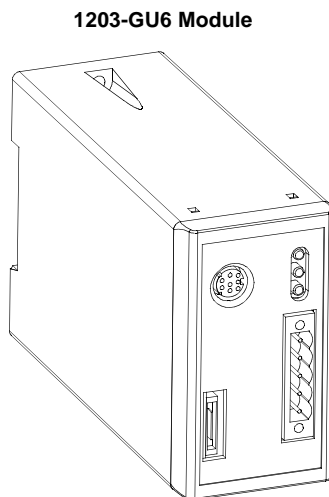
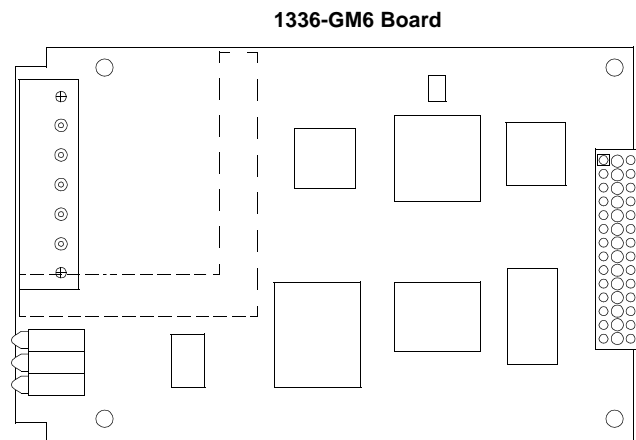

Figure 1.1
1203-GU6 Module and 1336-GM6 Board



The 1203-GU6 module mounts on a DIN rail and connects to the SCANport product via a SCANport cable. The 1336-GM6 board is mounted directly onto selected SCANport products so it connects to the SCANport product via an internal SCANport connector.

Both types of Enhanced DeviceNet communications adapter provide an electronic communications interface between a DeviceNet network and any single SCANport product.

Figure 1.2
Example of 1203-GU6 Modules Connecting SCANport Products to DeviceNet

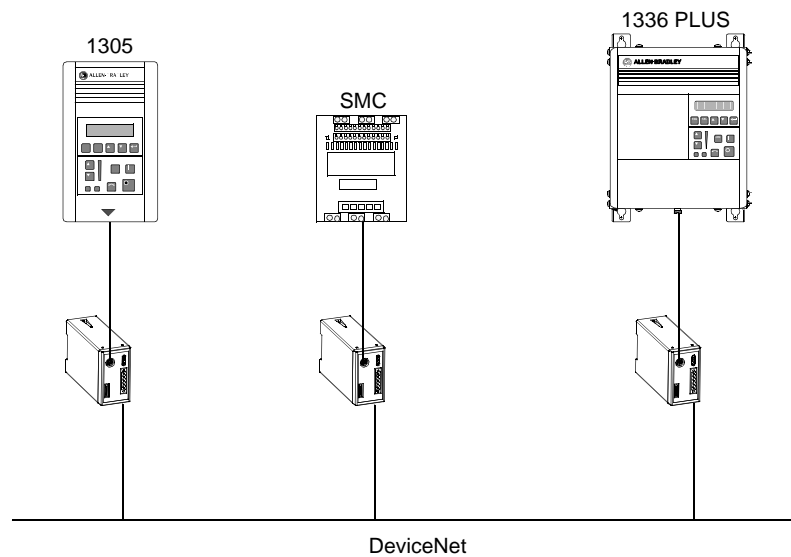

In Figure 1.2, a SCANport cable connects a 1203-GU6 module to a SCANport product through a port on the SCANport product. A DeviceNet cable connects the module to the DeviceNet network. The module then translates the DeviceNet messages into SCANport messages that can be understood by the connected product.

Features of the Communications Adapter

The DeviceNet network is an open, global industry-standard communication network designed to provide an interface through a single cable from a programmable controller directly to “smart” devices such as sensors, push buttons, motor starters, simple operator interfaces and drives.

The 1203-GU6 module and 1336-GM6 board let you connect your SCANport products to a DeviceNet network. These adapters feature the following:

- Flash upgradeability allows for field updates in the event of changes to the adapter’s firmware.
- COS (Change of State) capability lets you customize this device’s activity on the network by configuring the adapter to report only new data.
- Cyclic operation lets you customize the devices’s activity on the network by configuring the adapter to report its data at specific intervals.

-
- Peer I/O capabilities let the drive's I/O (logic command, reference, logic status, feedback and datalinks) be broadcast to or received from other drives connected via 1203-GU6 or 1336-GM6 adapters.
 - Software configuration lets you configure the adapter using DeviceNet Manager, RSNetWorx for DeviceNet, or HyperTerminal (a standard Windows 95 program).
 - Faulted Node Recovery lets you change items, such as a node address, of a device even when it is faulted on the network. (This feature requires the support of proper PC software tools.)
 - User-configurable fault response provides the ability to customize the adapter's actions to communication errors.
 - A miniature RS-232 port on the front of the 1203-GU6 (not available on the 1336-GM6) provides access for your PC to change parameters in the module using HyperTerminal. It also provides a DF1 connection for DriveTools32. (You must configure DriveTools32 and RSLinx for DF1 communications and then connect to the module using a 1203-SFC cable [sold separately].)
 - A new Module Status LED helps to diagnose network, module, and SCANport product health.
 - Re-designed power supply receives its operating power from the connected drive product. Only minimal DeviceNet-side transceiver power is consumed by the user-supplied 24V DC power source.

SCANport Products

Some SCANport products support one peripheral; others support up to six peripherals. The table below lists SCANport products, the number of peripherals each supports, the minimum and maximum I/O words, and the type of adapter that can be used.

Product	Number of Peripherals Supported	I/O Words		Adapter Use	
		Minimum	Maximum	1203-GU6	1336-GM6
1305 AC MICRO Drive	5	0	10	Yes	No
1336 IMPACT™ Drive	6 ^①	0	10	Yes	Yes ^②
1336 PLUS AC Drive	6 ^①	0	10	Yes	Yes ^②
1336 PLUS II Drive	6 ^①	0	10	Yes	Yes
1336 FORCE™ Drive	6 ^①	0	10	Yes	Yes ^③
1394 AC Multi-Axis Motion Control System	5	0	10	Yes	No
SMC Dialog Plus	1	0	2	Yes	No
SMP-3 Smart Motor Protector	2	0	2	Yes	No
1397 Digital DC Drive	5	0	10	Yes	No
1557 Medium Voltage Drive	5	0	10	Yes	No

① Lower horsepower products may not support a sixth peripheral. Refer to your user manual to verify that your product supports a sixth peripheral.

② Drive must be 30 hp or above.

③ Drive must be 30 hp or above, and it must use a standard adapter board.

Important: To connect multiple peripherals to a SCANport product, a port expander may be required. Refer to your product's documentation for more information.

Important: If you intend to use datalinks to communicate with and control your SCANport product, verify that your SCANport product supports datalinks before enabling them in the adapter.

Hardware and Parts Description

The hardware included with the adapter depends on the adapter that you have.

1203-GU6 Module Hardware

Figure 1.3 illustrates and the following table lists the main parts of the 1203-GU6 Enhanced DeviceNet communications module:

Figure 1.3
Parts of the 1203-GU6 Module

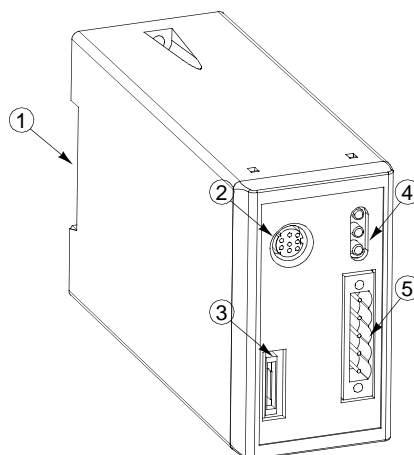

Number	Part	Description
1	DIN Rail Mount	Securely attaches and electronically grounds the module to the DIN rail.
2	SCANport Connection	Provides a standard SCANport 8-pin circular mini-DIN connector for the SCANport cable.
3	RS-232 Serial Port	Provides a connection for terminals capable of RS-232 serial communications. This port can be used to edit the module's parameters, download a file needed to perform a flash to the module's operating code, and support devices that monitor and test the module. A 1203-SFC serial cable and a PC running a terminal emulation program or a VT100-compatible terminal are required to use this port.
4	Bi-Color LEDs	Indicate the status of the DeviceNet media channel, of the SCANport connection, and of the module. For more information, refer to Chapter 8, Troubleshooting.
5	DeviceNet Connection	Provides a 5-pin Phoenix connector to attach the module to the network.
Not shown	5-Pin Plug-In Connector	This part is supplied with the module. The 5-pin plug-in connector (P/N 22112-215-01) is a connector to attach to the cable.
Not shown	10-Pin Plug-In Connector	This part is supplied with the module. The 10-pin plug-in connector (P/N 94220605) is a connector to attach to the cable.

1336-GM6 Board Hardware

Figure 1.4 illustrates and the following table lists the main parts of the 1336-GM6 Enhanced DeviceNet communications board:

Figure 1.4
Parts of the 1336-GM6 Board

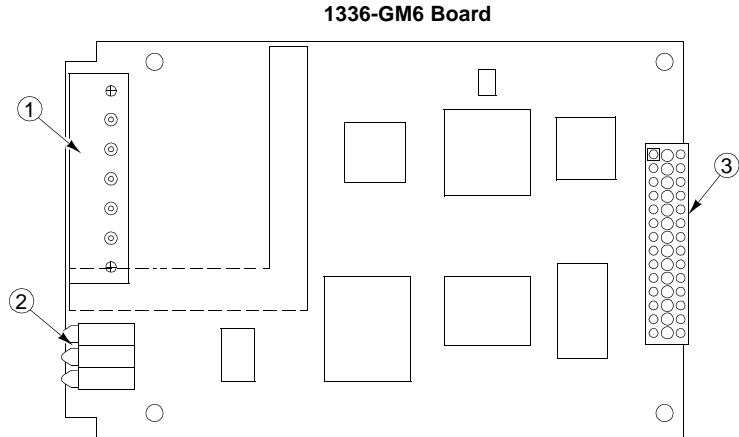

Number	Part	Description
1	DeviceNet Connection	Provides a 5-pin Phoenix connector to attach the module to the DeviceNet network.
2	Bi-Color LEDs	Indicate the status of the DeviceNet media channel, of the SCANport connection, and of the module. For more information, refer to Chapter 8, <i>Troubleshooting</i> .
3	SCANport Connection	Provides a 14-pin connector containing power and SCANport communication circuitry.
Not Shown	Kit	Provides the necessary materials for mounting the board to the SCANport product. These materials include one grounding wrist strap (P/N 22803-016-01), four Phillips mounting screws (P/N 28159-036-26), four stand-off nylon headers (P/N 22805-030-01), one 5-pin connector (P/N 22112-215-01), and one snap-in comm housing (P/N 188578) with mounting instructions (P/N 189572).

Overview of Setting Up the Adapter

To set up the Enhanced DeviceNet adapter, you must perform the following tasks:

1. Install the module or mount the board. Refer to Chapter 2, *Installation*.
2. Set the adapter's node address and configure the adapter's parameters. Refer to the following table:

If using:	Then refer to:
1203-GU6 module's serial connection	Chapter 3, <i>Configuring the 1203-GU6 Enhanced DeviceNet Module Using a Serial Connection</i>
1203-GU6 module's DeviceNet connection	Chapter 4, <i>Configuring the Enhanced DeviceNet Adapter Using DeviceNet Manager</i>
1336-GM board	Chapter 4, <i>Configuring the Enhanced DeviceNet Adapter Using DeviceNet Manager</i>

3. Configure a scanner (either PLC or SLC) to communicate with the Adapter. Refer to Chapter 5, *Configuring a Scanner to Communicate with the Adapter*.
4. If necessary, create a ladder logic program to control the SCANport product. Refer to Chapter 6, *Ladder Logic Programming*.

Required Tools and Equipment

The tools and equipment required, depend on if you are using a 1203-GU6 module or 1336-GM6 board.

1203-GU6 Module

To install and configure a 1203-GU6 module, you need the following:

- Enhanced DeviceNet communications module (1203-GU6).
- 5-pin or 10-pin plug-in connector (supplied with module).
- 35 x 7.5 mm DIN rail A (Allen-Bradley part number 199-DR1; 46277-3; EN 50022).
- 1/8" flathead screwdriver.
- Appropriate cables for SCANport and DeviceNet connections. Refer to the Selecting Cables section in Chapter 2, *Installation*.
- A 1203-SFC serial cable.
- A PC running either a Windows terminal emulation program (e.g., HyperTerminal) or a VT100-compatible terminal.

- A PC that is:
 - Running DeviceNet Manager.
 - Connected to and communicating with the DeviceNet network using a 1784-PCD card or a 1770-KFD adapter.
 - Running RS Linx.
 - Running RSLogix5 (if using PLC) or RSLogix500 (if using SLC).

Important: Refer to <http://www.software.rockwell.com> for more information on these software products.

1336-GM6 Board

To install and configure a 1336-GM6 board, you need the following:

- Enhanced DeviceNet communications board (1336-GM6).
- A kit that includes one grounding wrist strap, four Phillips mounting screws, four stand-off nylon headers, one 5-pin connector and one snap-in comm housing with mounting instructions (supplied with board).
- #1 Phillips screwdriver.
- Appropriate cable for the DeviceNet connection. Refer to the Selecting Cables section in Chapter 2, *Installation*.
- A PC that is:
 - Running DeviceNet Manager.
 - Connected to and communicating with the DeviceNet network using a 1784-PCD card or a 1770-KFD adapter.
 - Running RS Linx.
 - Running RSLogix5 (if using PLC) or RSLogix500 (if using SLC).

Important: Refer to <http://www.software.rockwell.com> for more information on these software products.

Installation

Chapter Objectives

Chapter 2 provides the information that you need to install the 1203-GU6 module or 1336-GM6 board. In this chapter, you will read about the following:

- Required tools and equipment.
- Selecting cables.
- Installing the adapter.
- Removing the adapter.

How you install the adapter depends on whether you are installing a 1203-GU6 module or 1336-GM6 board. Refer to the following table for information:

If installing:	Then refer to:
1203-GU6 module	"Installing a 1203-GU6 Module" on page 1
1336-GM6 board	"Installing a 1336-GM6 Board" on page 6

Installing a 1203-GU6 Module

Follow these procedures to install a 1203-GU6 module.

Required Tools and Equipment

To install your 1203-GU6 module, you will need the following tools and equipment:

- Enhanced DeviceNet communications module (1203-GU6).
- Either a 5-pin or 10-pin plug-in connector (supplied with module).
- 35 x 7.5 mm DIN rail A (Allen-Bradley part number 199-DR1; 46277-3; EN 50022).
- 1/8" flathead screwdriver.
- Appropriate cables for SCANport and DeviceNet connections. Refer to the "Selecting Cables" section in this chapter.

Selecting Cables

To connect the 1203-GU6 to the SCANport product and the DeviceNet network, you must select an appropriate DeviceNet cable and Allen-Bradley SCANport cable. Use the following information to select appropriate cables for each connection.

SCANport Cables

When selecting the SCANport cable to connect the 1203-GU6 module to the SCANport product, you need to:

- Use an Allen-Bradley SCANport cable. Refer to the table below.

Male to Male Connection		Male to Female Connection	
Length	Catalog Number	Length	Catalog Number
1/3 m	1202-C03	1/3 m	1202-H03
1 m	1202-C10	1 m	1202-H10
3 m	1202-C30	3 m	1202-H30
9 m	1202-C90	9 m	1202-H90

- Use less than 10 meters (33 feet) of cable between the SCANport product and adapter.
- Keep SCANport cables away from high power cables to guard against introducing noise into your system.

DeviceNet Cables

The 1203-GU6 module comes with either one 5-pin connector or a 5-pin and 10-pin connector. A drop line connects a node, such as an adapter, on the DeviceNet cable system to the DeviceNet trunk. When selecting a drop line, you need to:

- Select either a 5-pin connector or a 10-pin connector for the cable. (Both are included with the 1203-GU6 module).
 - Use the 5-pin connector if you are using a DeviceNet drop cable configuration.
 - Use the 10-pin connector if you are using a daisy-chaining configuration.
- Determine limitations of the trunk and drop cables. Refer to the following table.

Data Rates	125 Kbps	250 Kbps	500 Kbps
Thick Trunk Line	500 m (1,640 ft)	250 m (820 ft)	100 m (328 ft)
Thin Trunk Lengths	100 m (328 ft)	100 m (328 ft)	100 m ((328 ft)
Maximum Drop Length	6 m (20 ft)	6 m (20 ft)	6 m (20 ft)
Cumulative Drop Budget	156 m (512 ft)	78 m (256 ft)	39 m (128 ft)

For more information on DeviceNet cables and cable systems, refer to the DeviceNet Cable System Planning and Installation Manual, Publication DN-6.7.2.

Installing the 1203-GU6 Communications Module

The following instructions explain how to physically install your Enhanced DeviceNet 1203-GU6 communications module.

1. Hook the top lip of the module's DIN rail mount onto the top of the DIN rail and then rotate the module onto the DIN rail. You will hear the module snap into a locked position.

Figure 2.1
Mounting the Module onto the DIN Rail

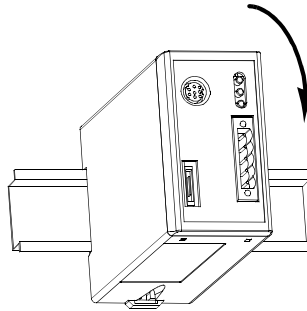

2. Remove power from the network.
3. Insert the DeviceNet cable wires into the desired connector. Make sure you follow the color key next to the connector receptacle on the module.



ATTENTION: If you wire the 5-pin or 10-pin header after you've connected it to the module, static control precautions are required. Device malfunction may occur if you do not follow ESD control procedures. If you are not familiar with static control procedures, refer to Allen-Bradley Publication 8000-4.5.2, *Guarding Against Electrostatic Damage*, or other applicable ESD protection handbook.

Figure 2.2
Inserting DeviceNet Cable Wires into the Connector

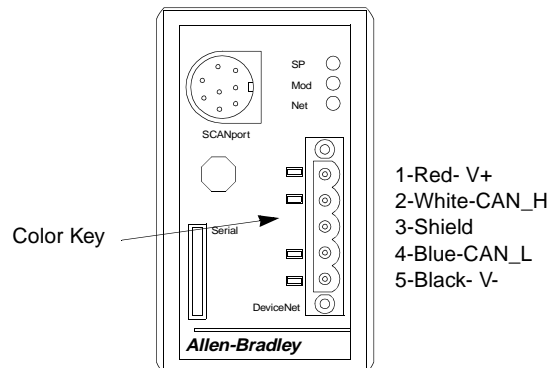

4. Plug the connector into the module.

Figure 2.3
Inserting a 5-pin or 10-pin Phoenix Connector

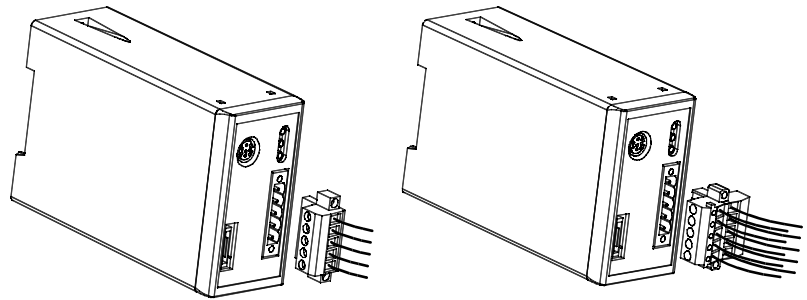

5. Use a 1/8" flathead screwdriver to screw the connector firmly into place.
6. Connect the SCANport cable to the communications adapter and then to the SCANport product.

Important: Because the adapter's power comes from the SCANport product, the adapter will not function if the SCANport product is not powered.

Figure 2.4
Inserting the SCANport Cable

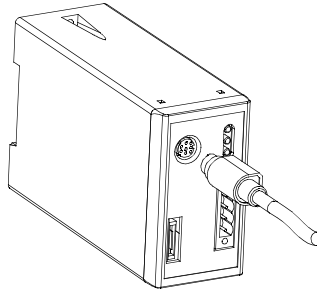

7. Reapply power to the network.
8. If necessary, apply power to the connected SCANport product.

Your 1203-GU6 module is now installed. The SCANport LED is green. The network and module LEDs are blinking green. If your module's LEDs are different, refer to Chapter 8, *Troubleshooting*, for more information.

You must now edit the adapter's node address, and you may want to edit some of its other parameters. Refer to the following table for information:

If using:	Then refer to:
1203-GU6 module's serial connection	Chapter 3, <i>Configuring the 1203-GU6 Enhanced DeviceNet Module Using a Serial Connection</i>
1203-GU6 module's DeviceNet connection	Chapter 4, <i>Configuring the Enhanced DeviceNet Adapter Using DeviceNet Manager</i>

Removing the 1203-GU6 Communications Module

To remove the 1203-GU6 communications module, you need to:

1. If necessary, remove any serial connections from the DF-1 serial port.
2. Remove the SCANport cable from the SCANport product and then from the module. This will power down the module if the SCANport product is powered.
3. Unscrew (using a 1/8" flathead screwdriver) and then unplug the 5-pin or 10-pin connector from the module.
4. Insert a flathead screwdriver into the module's DIN rail tab release and gently push the handle toward the module to release the connection tab. Then pull the module up and off the DIN rail.

Figure 2.5
Mounting the Module onto the DIN Rail

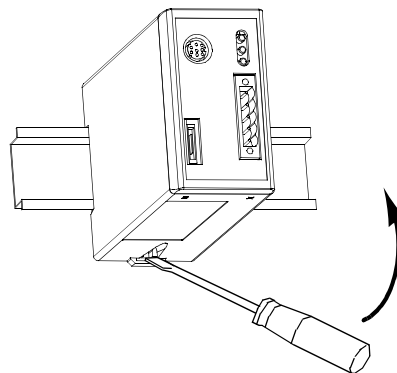

Installing a 1336-GM6 Board

Follow these procedures to install a 1336-GM6 board.

Required Tools and Equipment

To install your 1336-GM6 board, you will need the following tools and equipment:

- Enhanced DeviceNet communications board (1336-GM6).
- A kit that includes one grounding wrist strap, four Phillips mounting screws, four stand-off nylon headers, one 5-pin connector and one snap-in comm housing with mounting instructions (supplied with board).
- #1 Phillips screwdriver.
- Appropriate cable for the DeviceNet connection. Refer to the Selecting Cables section below.

Selecting Cables

To connect the Enhanced DeviceNet adapter to the SCANport product and the DeviceNet network, you must select an appropriate DeviceNet cable. Use the following information to select appropriate cables for each connection.

DeviceNet Cables

The 1336-GM6 board comes with one 5-pin connector. A drop line connects a node, such as an adapter, on the DeviceNet cable system to the DeviceNet trunk. When selecting a drop line, you need to:

- Use the 5-pin connector for the cable if you are using a DeviceNet drop cable configuration.
- Determine limitations of the trunk and drop cables. Refer to the following table.

Data Rates	125 Kbps	250 Kbps	500 Kbps
Thick Trunk Line	500 m (1,640 ft)	250 m (820 ft)	100 m (328 ft)
Thin Trunk Lengths	100 m (328 ft)	100 m (328 ft)	100 m ((328 ft)
Maximum Drop Length	6 m (20 ft)	6 m (20 ft)	6 m (20 ft)
Cumulative Drop Budget	156 m (512 ft)	78 m (256 ft)	39 m (128 ft)

For more information on DeviceNet cables and cable systems, refer to the DeviceNet Cable System Planning and Installation Manual, Publication DN-6.7.2.

Electrostatic Discharge Precautions

Please read the following safety precaution carefully before installing the 1336-GM6 communications board.



ATTENTION: The 1336-GM6 communications board contains ESD (Electrostatic Discharge) sensitive parts. Static control precautions are required when installing, testing, or servicing this board. Device malfunction may occur if you do not follow ESD control procedures. If you are not familiar with static control procedures, refer to Allen-Bradley Publication 8000-4.5.2, *Guarding Against Electrostatic Damage*, or other applicable ESD protection handbook.

Installing the 1336-GM6 Communications Board

The following instructions explain how to physically install an Enhanced DeviceNet 1336-GM6 communications board.

Important: If you are attaching the communications board to a 1336 PLUS II, refer to the one-page insert included with the kit for mounting instructions.

Important: To prevent damage to the board, you must wear a grounding wrist strap when handling the 1336-GM6 communications board.



ATTENTION: Remove all power from the SCANport product before installing the 1336-GM6 board. Failure to disconnect power may result in death or serious injury. Verify all power is removed before installing the 1336-GM6 board.

1. Make sure you've turned off the power supply to the SCANport product and DeviceNet network and verified the drive is not receiving power.

2. Screw the four stand-off nylon headers into the appropriate spaces on the drive's main control board.

Figure 2.6
Mounting the Open Style Communications Board

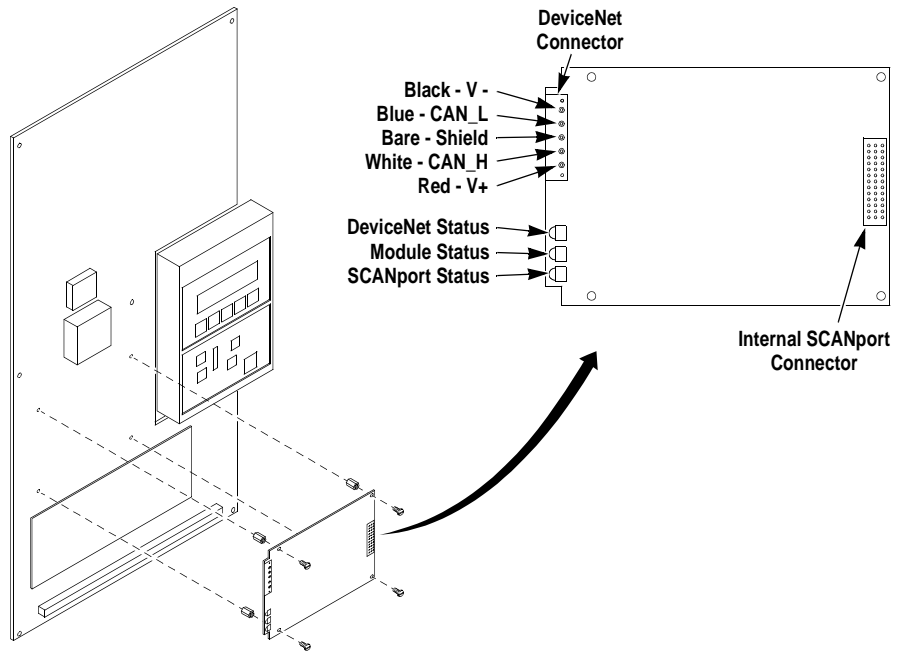

3. Insert the pins located on the 1336-GM6 into the 14-pin SCANport header on the drive. The board should sit squarely on the stand-offs.
4. Using a #1 Phillips screwdriver and the four supplied mounting screws, screw the board securely into place, being careful not to overtighten.
5. Attach the wires to the supplied DeviceNet connector.

Important: Refer to Figure 2.6 to verify you've wired the connector correctly to the board. Failure to wire the board correctly may damage the circuitry or cause the device to not function.



ATTENTION: Static control precautions are required if you wire the connector when it is already connected to the adapter. It is not recommended that you do this. Device malfunction may occur if you do not follow ESD control procedures. If you are not familiar with static control procedures, refer to Allen-Bradley Publication 8000-4.5.2, *Guarding Against Electrostatic Damage*, or other applicable ESD protection handbooks.

6. Plug the connector into the board receptacle and screw the two screws into place using a 1/8" flathead screwdriver.

7. Reapply power to the SCANport product.
8. Reapply power to the DeviceNet network.

Your 1336-GM6 board is now installed. The SCANport LED is green. The network and module LEDs are blinking green. If your module's LEDs are different, refer to Chapter 8, *Troubleshooting*, for more information.

You must now edit the adapter's node address, and you may want to edit some of its other parameters. Refer to Chapter 4, *Configuring the Enhanced DeviceNet Adapter Using DeviceNet Manager*.

Removing the 1336-GM6 Communications Board

To remove the 1336-GM6 communications board, you need to:

Important: To prevent damage to the board, you must wear a grounding wrist strap when handling the 1336-GM6 communications board.

Important: If you are removing the communications board from a 1336 PLUS II, refer to the one-page insert included with the kit for special mounting instructions.



ATTENTION: Remove all power from the SCANport product before removing the 1336-GM6 board. Failure to disconnect power may result in death or serious injury. Verify all power is removed before installing the 1336-GM6 board.

1. Turn off the power supply to the drive and DeviceNet network.
2. Unscrew (using a 1/8" flathead screwdriver) and then unplug the DeviceNet connector from the communications board.
3. Unscrew and remove the board's four mounting screws with a #1 Phillips screwdriver.
4. Making sure not to bend the pins as they slide out of the 14-pin SCANport header, gently pull the communications board away from the main control board.
5. Unscrew and remove the four stand-offs from the main control board.