

A
BUS:
 2x FEMALE M12 4P D-CODE

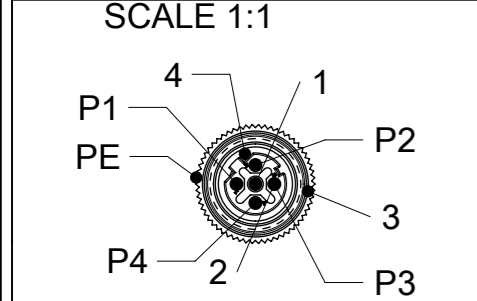

WIRING INFORMATION
 P1 TX+
 P2 RX+
 P3 TX-
 P4 RX-

B
INPUT / OUTPUT:
 8x FEMALE M12 5P A-CODE

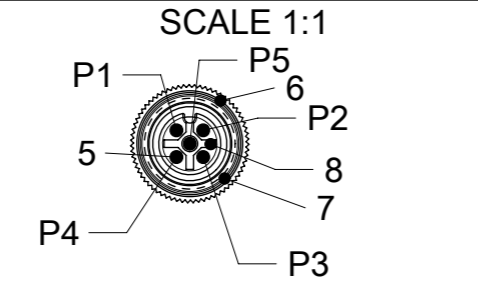

WIRING INFORMATION INPUT
 P1 - +24 VDC
 P2 - Input (even)
 P3 - 0 V (Ground)
 P4 - Input (odd)
 P5 - PE (Protected Earth)

WIRING INFORMATION OUTPUT
 P1 - N/C
 P2 - Output (even)
 P3 - 0 V (Ground)
 P4 - Output (odd)
 P5 - PE (Protected Earth)

C
POWER IN
 MALE 7/8" 4PIN

POWER OUT
 FEMALE 7/8" 4PIN

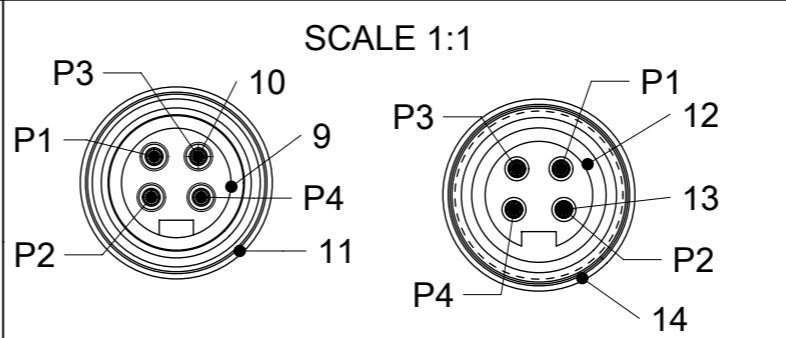

WIRING INFORMATION
 P1 - +24 VDC (Outputs Power)
 P2 - +24 VDC (Module & Inputs Power)
 P3 - 0 V (Module & Inputs Power)
 P4 - 0 V (Outputs Power)

POWER IN
 MALE 7/8" 5PIN

POWER OUT
 FEMALE 7/8" 5PIN

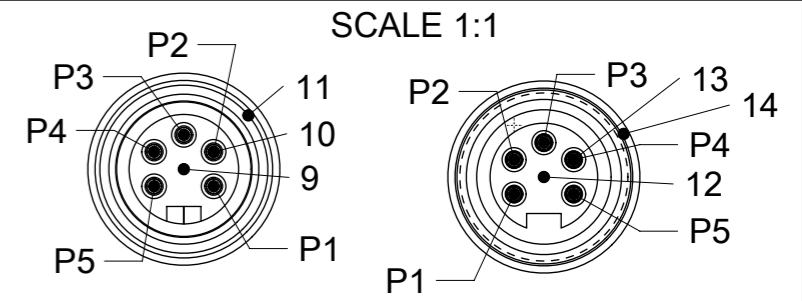

WIRING INFORMATION
 P1 - 0 V (Outputs Power)
 P2 - 0 V (Module & Inputs Power)
 P3 - PE (Protected Earth)
 P4 - +24 VDC (Module and Inputs Power)
 P5 - +24 VDC (Outputs Power)

BILL OF MATERIAL

ITEM	DESCRIPTION	MATERIAL	FINISH
1	INSERT	TPU	BLACK
2	CONTACT	COPPER ALLOY	GOLD OVERNICKEL
3	SHELL	BRASS	NICKEL PLATET
4	GASKET	FPM	RED
5	CONTACT	COPPER ALLOY	GOLD OVER NICKEL
6	GASKET	FPM	RED
7	SHELL	BRASS	NICKEL PLATET
8	INSERT	TPU	BLACK
9	INSERT	TPE	YELLOW
10	CONTACT	COPPER ALLOY	GOLD OVERNICKEL
11	SHELL	BRASS	NICKEL PLATET
12	INSERT	TPE	YELLOW
13	CONTACT	COPPER ALLOY	GOLD OVER NICKEL
14	SHELL	BRASS	NICKEL PLATET
15	WINDOW	PC	TRANSPARENT
16	SCREW	V2A	-
17	LABEL	PC	WHITE
18	FIBER OPTIC	PA	TRANSPARENT
19	WASHER	BRASS	NICKEL PLATET
20	SCREW	V2A	-
21	SHIELD PLATE	STAINLESS STEEL	-
22	RESIN	EPOXY	TRANSPARENT
23	LABEL	PVC	WHITE
24	HOUSING	PBT	BLACK
25	LABEL	PVC	YELLOW

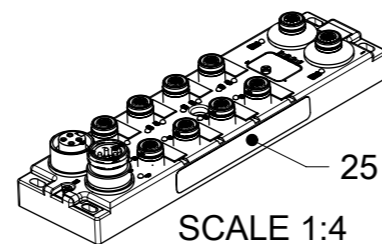

SCALE 1:4

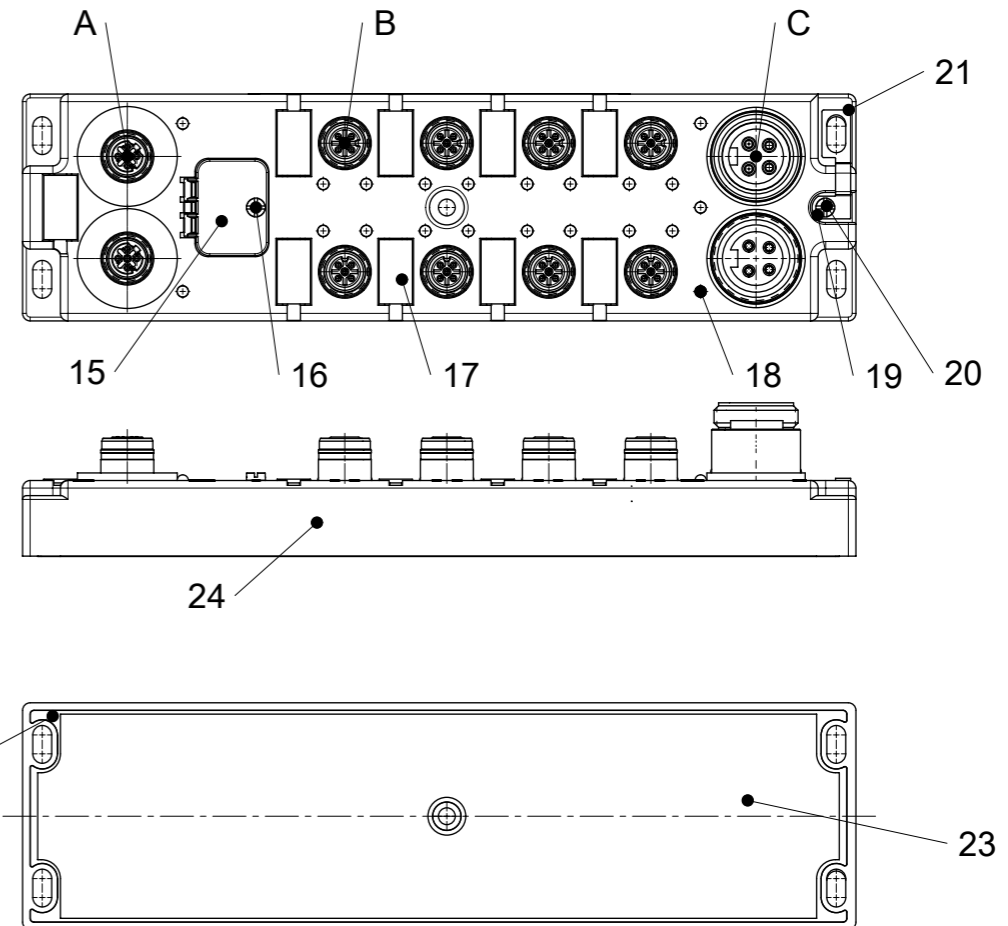

SYMBOLS	THIS DRAWING CONTAINS INFORMATION THAT IS PROPRIETARY TO MOLEX ELECTRONIC TECHNOLOGIES, LLC AND SHOULD NOT BE USED WITHOUT WRITTEN PERMISSION		CURRENT REV DESC: ADD NEW P/N'S		
	DIMENSION UNITS	SCALE			
▽ = 0	mm	1:2			
▽ = 0	GENERAL TOLERANCES (UNLESS SPECIFIED)				
▽ = 0	ANGULAR TOL ± °				
▽ = 0	4 PLACES ±		EC NO: 171585		
▽ = 0	3 PLACES ±		DRWN: RSCHIEBER 2018/01/22		
▽ = 0	2 PLACES ±		CHK'D: ULETENMEIER 2018/02/01		
▽ = 0	1 PLACE ±	0.3	APPR: RSILLER 2018/02/05		
▽ = 0	0 PLACES ±	0.5	INITIAL REVISION:		
□ = 0	DRAFT WHERE APPLICABLE MUST REMAIN WITHIN DIMENSIONS		DRWN: ULETENMEIER 2015/01/19		
▽ = 0	THIRD ANGLE PROJECTION		APPR: JALEXANDER 2015/06/25		
		DRAWING	SERIES	MATERIAL NUMBER	CUSTOMER
		A3-SIZE	112095	SEE TABLE 1,2,3,4,5,6	GENERAL MARKET
		DOCUMENT NUMBER		DOC TYPE	DOC PART
		1120950007		PSD	000
		SHEET NUMBER		REVISION	
		2 OF 8		B	

